

Installation, Operation & Maintenance Manual

Sliding-Vane Stationary Pumps for LPG and NH₃ All Models 51, 521, and 1021

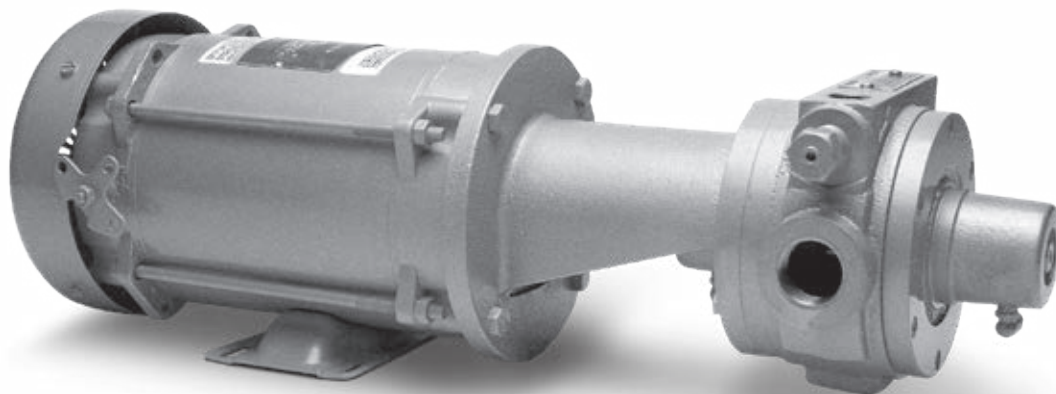

D51 Model

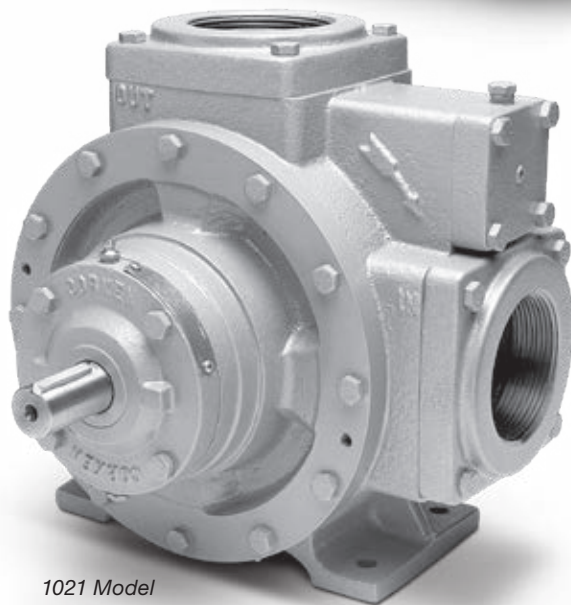

1021 Model

Warning: (1) Periodic inspection and maintenance of Corken products is essential. (2) Inspection, maintenance and installation of Corken products must be made only by experienced, trained and qualified personnel. (3) Maintenance, use and installation of Corken products must comply with Corken instructions, applicable laws and safety standards. (4) Transfer of toxic, dangerous, flammable or explosive substances using Corken products is at user's risk and equipment should be operated only by qualified personnel according to applicable laws and safety standards.

Solutions beyond products...

CORKEN[®]

Warning

Install, use and maintain this equipment according to Corken's instructions and all applicable federal, state, local laws and codes. Periodic inspection and maintenance is essential.

Corken One Year Warranty

CORKEN, INC. warrants that its products will be free from defects in material and workmanship for a period of one year from date of installation, provided that the warranty shall not extend beyond twenty-four (24) months from the date of shipment from CORKEN. If a warranty dispute occurs, the DISTRIBUTOR may be required to provide CORKEN with proof of date of sale. The minimum requirement would be a copy of the DISTRIBUTOR'S invoice to the customer.

CORKEN products which fail within the warrant period due to defects in material or workmanship will be repaired or replaced at CORKEN's option, when returned, freight prepaid to CORKEN, INC., 9201 North I-35 Service Road, Oklahoma City, OK. 73131.

Parts subject to wear or abuse, such as mechanical seals, blades, piston rings, valves and packing, and other parts showing signs of abuse, neglect or failure to be properly maintained are not covered by this limited warranty. Also, equipment, parts and accessories not manufactured by CORKEN but furnished with CORKEN products are not covered by this limited warranty and the purchaser must look to the original manufacturer's warranty, if any. This limited warranty is void if the CORKEN product has been altered or repaired without the consent of CORKEN.

All implied warranties, including any implied warranty of merchantability or fitness for a particular purpose, are expressly negated to the extent permitted by law and shall in no event extend beyond the expressed warrantee period.

CORKEN DISCLAIMS ANY LIABILITY FOR CONSEQUENTIAL DAMAGES DUE TO BREACH OF ANY WRITTEN OR IMPLIED WARRANTY ON CORKEN PRODUCTS. Transfer of toxic, dangerous, flammable or explosive substances using CORKEN products is at the user's risk. Experienced, trained personnel in compliance with governmental and industrial safety standards should handle such substances.

Important notes relating to the European Union (EU) Machinery Directive

Pumps delivered without electric motors are not considered as machines in the EU Machinery Directive. These pumps will be delivered with a Declaration of Incorporation. The fabricator of the machinery must assure and declare full compliance with this Directive before the machine in which the pump will be incorporated, or of which it is a part, is put into service.

Contacting the Factory

Before contacting the factory, note the model and serial numbers. The serial number directs Corken personnel to a file containing all information on material specifications and test data applying to the product. When ordering parts, the Corken service manual or Installation, Operations, and Maintenance (IOM) manual should be consulted for the proper part numbers. ALWAYS INCLUDE THE MODEL NUMBER AND SERIAL NUMBER WHEN ORDERING PARTS.

The model and serial numbers are shown on the nameplate of the unit. Record this information for future reference.

Model No. _____

Serial No. _____

Date Purchased _____

Date Installed _____

Purchased From _____

Installed By _____

Table of Contents

Principles of a Sliding-Vane Pump	4
Exclusive Features of the Coro-Vane® Pump	4
Chapter 1—Installation Procedures	4
1.1 Location	4
1.2 The Inlet Piping Should Include the Following:	6
1.3 The Outlet Piping Should Include the Following:	6
1.4 The Bypass System Must Include the Following:	6
1.5 A Vapor Equalizing System Should be Included:	6
1.6 Driver Installation	6
Chapter 2—Operation Procedures	7
Chapter 3—Maintenance Procedures	8
3.1 Preventative Maintenance Procedures	9
Chapter 4—Seal Replacement Instructions	10
4.1 Repair Kits and Spare Parts for Sliding-Vane Pumps	13
Appendices	
A. Model Number Identification Code and Available Options	14
B. Specifications	16
C. Performance	18
D. Outline Dimensions	21
E. Parts Details	28
F. V-Belt Selection	35
G. Troubleshooting Guide	36
H. Extended Storage	37

Principles of a Sliding-Vane Pump

Corken's Coro-Vane® pumps are a special type of rotary positive displacement pump, known as a sliding vane pump.

The sliding-vane pump has many of the positive displacement advantages of the gear pump, plus the ability to compensate for wear, and operate at a lower noise level.

The sliding-vane pump consists of a rotor turning in a cam (liner) machined eccentrically in relation to the rotor; thereby displacing the liquid trapped between the rotor, cam and vanes. Coro-Vane® pumps are made with vanes produced from advanced polymers which exhibit extremely low coefficients of friction. The vanes self-adjust for wear and extends the pump life.

Exclusive Features of the Coro-Vane® Pump

The pumping of volatile liquids is one of the most difficult of all pumping jobs, so more attention must be given to the design and manufacture of the pump and to its installation and operation.

In addition to being especially suited for handling volatile liquids, the Coro-Vane® pump has a number of features to help make it more easily operated and maintained.

Coro-Vane® pumps are manufactured in six models: the Models D51 and F51 small stationary and the Models 521, 1021, F1021 and F1521 stationary pumps. The Models F1021 and F1521 have ANSI flanged connections. All six models have been registered and listed by the UNDERWRITERS' LABORATORIES, INC. for use in the handling of LP-Gas and Ammonia.

The CASE AND HEADS are made of ductile iron for extra strength and toughness.

The VANES are manufactured of advanced polymers to provide excellent life and quiet operation. After long service, the vanes are simply and inexpensively replaced.

Both the CAM and the SIDEPLATES are easily replaced should the need arise.

The MECHANICAL SEAL is designed for longer life under greater loads and may be inspected or replaced without disturbing the piping of the pump. No special tools are needed.

BEARINGS are heavy-duty roller type for long bearing life.

PRESSURE GAUGE connections, 1/4" pipe thread, are provided.

The PUMP NOZZLES on Models 521 and 1021 are equipped with flanges to simplify piping. It is not necessary to provide unions in the piping system near the pump because the flanges serve this purpose.

The RELIEF VALVE is built-in as part of the pump on models 521 and 1021 and is adjustable under pressure.

NOTE: EVEN WITH THIS INTERNAL SAFETY VALVE, AN EXTERNAL BYPASS VALVE MUST BE INSTALLED.

Chapter 1—Installation Procedures

1.1 Location

The installation of the Coro-Vane® pump is simple; however, in order for the pump to deliver optimum performance, the principles discussed in this book should be followed. The piping details in figure 1.2 illustrate methods proved by hundreds of installations. Your own needs may require slight variations, but every effort should be made to follow the recommendations identified in this manual.

No pump can discharge more liquid than it receives, so the pump location and the inlet piping must be given careful attention. If the inlet piping is unable to supply the demand of the pump, you may expect trouble. The inlet sizes shown in figure 1.2 are the smallest piping size you can use with success.

For the transfer of flammable liquids like LPG, the pump must be installed according to the applicable local safety and health regulations. The installer and/or the user must take into account the following:

- The pump must be located as near the storage tank as possible. The complete inlet line, including the vertical line from the tank must not exceed twelve feet (3.7 m) in length.
- The bottom of the tank must be no less than two feet (0.6 m) above the pump inlet nozzle, with four feet (1.2m) considered standard.
- The foundation for the pump is important. The foundation must be firm, level and preferably made of concrete. The suggestions in figure 1.1 should be observed.

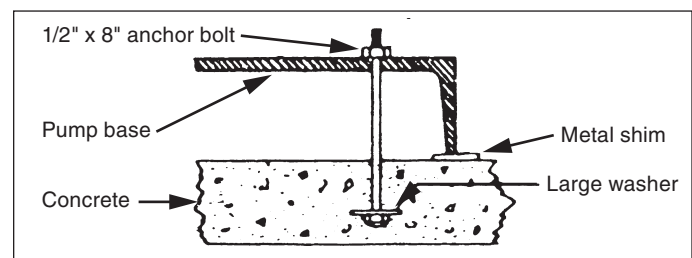

Figure 1.1

- Potential risk due to local conditions regarding the installation and operation (e.g. poor ventilation and additional risks due to other elements in the vicinity, etc.).
- Qualification of the personnel.
- Type of liquid being transferred.
- Specific safety measures to be applied (e.g. gas detection, automatic shut-off valves, personal protective equipment, etc.).

should be used. Web slings are preferred over metal slings to minimize damage to the paint. See Appendix D for outline dimensions.

Model	Shipping Weight: lb (kg)
D51	50 (22.7)
F51	25 (11.3)
521	132 (59.9)
1021	200 (90.7)
F1021	200 (90.7)
F1521	235 (106.6)

The following table shows the weight of the bare pump for each model. For handling a bare pump, lifting slings

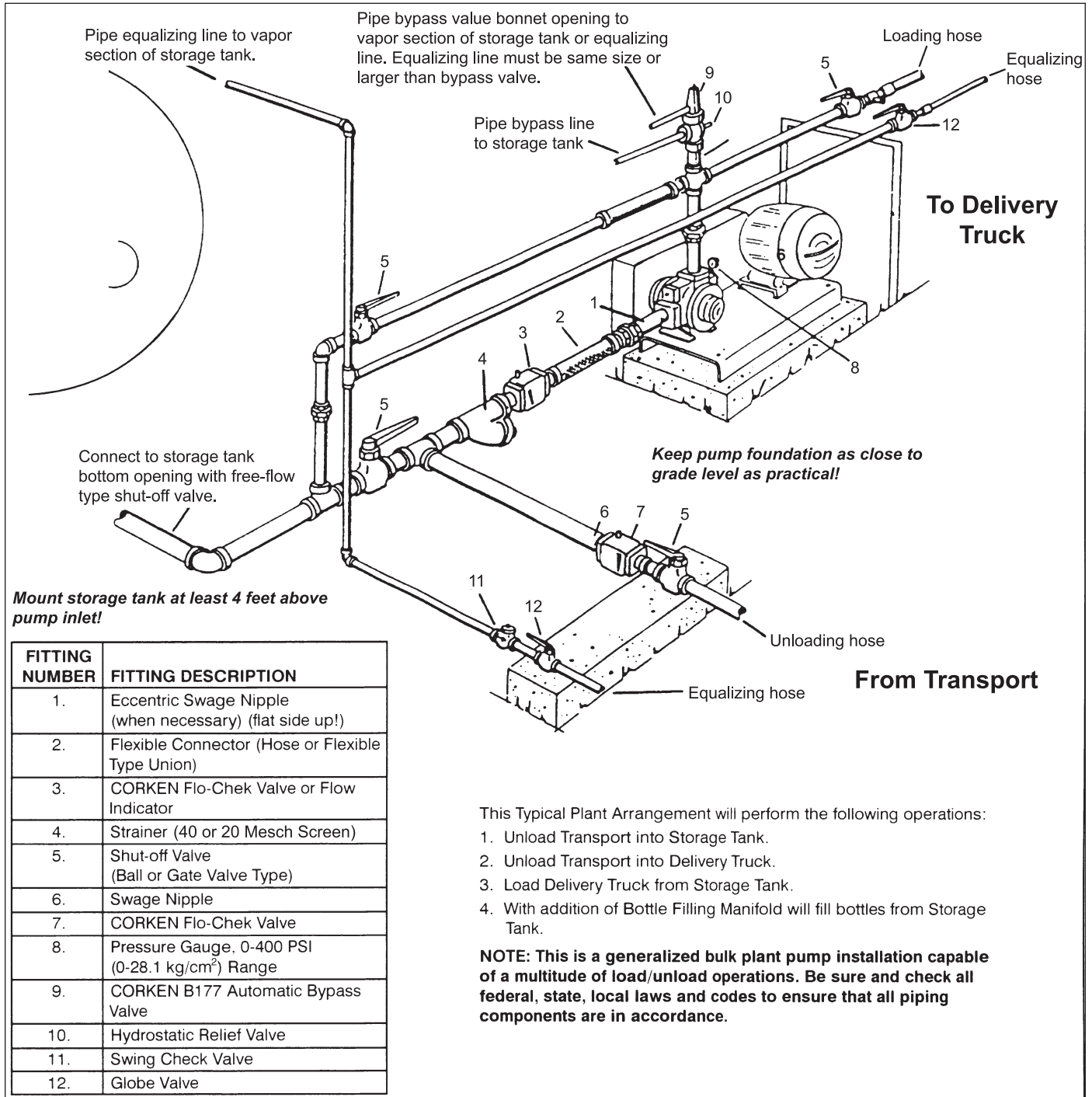

Figure 1.2: Typical Piping Diagram

1.2 The Inlet Piping Should Include the Following:

1. The tank excess flow valve (EFV) should have a flow rate of 1-1/2 to 2 times the capacity of the pump. Do not use an EFV without knowing its flow capacity.
2. The tank shut-off valve must be a free-flow type and not a standard globe valve.
3. A strainer of the "Y" type, with 30 to 40 mesh screen, must be on the inlet line of the pump. (Mesh size indicates the number of openings per lineal inch).
4. Use a flexible connection in the pump inlet and outlet piping to compensate for piping strains.
5. Use an eccentric swage at the pump inlet nozzle to change the line size (flat side up).
6. Make the inlet line level or slope it downward to the pump.
7. The minimum inlet piping sizes shown in figure 1.2 must be observed.

1.3 The Outlet Piping Should Include the Following:

1. A pressure gauge should be installed in the pump outlet or near it. A pressure gauge is necessary to determine the efficiency of your pumping system.
2. A hydrostatic relief valve is required by most state laws and for your own safety.
3. If the outlet piping exceeds 50 feet (15.2 m) in length a check valve should be installed near the pump outlet.
4. The minimum outlet piping sizes shown in figure 1.2 should be observed.

1.4 The Bypass System Must Include the Following:

1. A pump bypass system must be installed. If the pump discharge is shut off before the driver is stopped, dangerously high pressures can develop, unless a bypass valve is installed to permit the pump to discharge back to the supply tank, at a predetermined pressure.
2. The pump may have an internal relief valve, but it is intended as a safety relief valve device and not an operational bypass.
3. Always install an external bypass relief valve (such as the Corken B177) in the pump discharge line. The bypass valve may discharge into the tank at any convenient opening, either liquid or vapor; however, it should not connect into the pump inlet piping system.

Model	Maximum Differential Pressure
521, 1021, F1021	125 psi (8.8 kg/cm ²)
F1521	100 psi (7.0 kg/cm ²)

1.5 A Vapor Equalizing System Should be Included:

To obtain maximum performance from the Coro-Vane® pump, a vapor equalizing system should be installed. This system is simply a pipe connecting the vapor sections of the tank being unloaded and the tank being filled. This equalizing line allows vapor to move freely between the two tanks (in either direction) and assures that both tanks remain at the same pressure.

As liquid is withdrawn from a tank, it must be replaced by an equal amount of vapor or the pressure in the tank will drop. If an equalizing line is not present, this vapor is formed by "boiling" of the liquid and a reduction of the tank's pressure. Meanwhile, the tank being filled experiences a pressure increase as the rising fluid levels compresses the vapor space above it. A vapor equalizing line will eliminate both of these problems and will reduce pumping time, differential pressure, noise and wear on the entire system. Slow transfer rates will minimize these effects and reduce the need for a vapor equalizing line. However, today's high transfer rates require the installation of a vapor equalization line.

Another way to consider this principle is to remember how it takes two holes in an oil can for oil to be poured smoothly from the can; one for the oil to exit and the other for the air to enter. The piping and hose sizes shown in figure 1.2 are minimum requirements.

1.6 Driver Installation

Model	Maximum Speed
521, 1021, F1021	950 RPM
F1521	860 RPM

The wiring of your electric motor is extremely important and must be done by a competent electrical contractor. The following wire sizing chart indicates the minimum standards for wire sizes.

Hp	Motor			Recommended wire size, AWG ¹		
	Motor Phase	Volts	Approximate Full Load Amperes	Length of Run (ft)		
				0-100	to 200	to 300
3	1	115	34.0	6	4	2
		220	17.0	12	8	8
	3	230	9.6	12	12	12
		460	4.8	12	12	12
5	1	115	56.0	4	1	1/0
		230	28.0	10	6	4
	3	230	15.2	12	12	10
		460	7.6	12	12	12
7-1/2	1	230	40.0	8	6	4
	3	230	22.0	10	10	8
		460	11.0	12	12	12
10	3	230	28.0	8	8	8
		460	14.0	12	12	12
15	3	230	42.0	6	6	6
		460	21.0	10	10	10
20	3	230	54.0	4	4	4
		460	27.0	8	8	8
25	3	230	68.0	2	2	2
		460	34.0	6	6	6
30	3	230	80.0	1	1	1
		460	40.0	6	6	6
40	3	230	100.0	2/0	2/0	2/0
		460	52.0	4	4	4
50	3	230	130.0	3/0	3/0	3/0
		460	65.0	2	2	2

¹ Based upon 3% voltage loss copper wire type TW. Single phase motor calculations are based on two times distance.

Improper motor wiring will cause expensive motor difficulties from low voltage. If you suspect you have low voltage, call your power company. Connecting your motor for the voltage you have available is important too. The motors furnished with the stationary pumps are usually dual voltage, so you must be sure of the voltage your power company is supplying you. Your motor will be completely ruined if it is connected to the wrong voltage.

A humid climate can cause problems, particularly in explosion proof motor applications. The normal breathing of the motor, and alternating between being warm when running and cool when stopped, often will cause moist air to be drawn into the motor housing. This moist air will condense, and may eventually add enough free water to the inside of the motor to cause it to fail. To prevent this, make a practice of running the motor and pump at least once a week on a bright, dry day for an hour or so (pumping through the bypass system). In this period the motor will heat up and vaporize the condensed moisture, and drive it out of the motor. No motor manufacturer will guarantee an explosion proof or totally enclosed motor against damage from moisture.

Engine drivers pose a special consideration. The manufacturer's instructions must be followed. When the stationary pump is equipped with an engine from the factory, the engine speed should normally not exceed 1,800 RPM. Excessive engine speed will overload the engine and cause early failure. The engine loses 3% of

its power for every 1,000 feet (305 m) above sea level, so if your installation is at a higher altitude than normal, consult the factory.

Chapter 2—Operation Procedures

Performance curves and charts are provided in [Appendix C](#).

The following steps should be performed for the initial pumping operation:

1. Verify the strainer screen is clean.
2. Rotate the pump by hand.
3. Check V-belt drive or direct drive coupling alignment. Misalignment will cause accelerated wear of the drive system, motor bearings and pump.
4. Check motor for proper wiring.
5. Review complete system to make certain the function of every valve and piece of equipment is clearly understood. Everyone operating this system must be properly trained in normal operating procedures and emergency procedures in event of a malfunction.
6. Close all hose valves.
7. Slowly open the storage tank bottom shut-off valve (suction line to the pump). Immediately check the system for leaks.
8. Open any shut-off valves between the bypass valve and the storage tank.
9. Make a note of all pressure gauge readings, especially the pressure gauge located at the discharge of the pump. Start the pump and circulate the liquid through the bypass system back to the storage tank.
10. Verify the proper pump rotation direction. There is an arrow cast in the pump case.
11. An ammeter may be used by adjusting the bypass valve until the ammeter indicates the full load motor amperage rating shown on the motor nameplate or maximum rated differential, whichever comes first. Permit the pump to circulate liquid for half an hour or more. If the motor overload protection device stops the motor in this period the bypass valve setting is too high and should be readjusted until the motor will run for half an hour. After a satisfactory setting is achieved, "seal" the valve adjusting stem to prevent tampering with the adjustment. See IH102 for more details on the use of the Corken bypass valves.
12. If your pump has an internal relief valve, it must be set higher than the external bypass setting. The internal relief valve may be adjusted while the pump

is under pressure by removing the flush seal plug. Turning the adjusting screw clockwise will decrease the internal relief valve setting. Replace the flush seal plug after adjustment.

13. After initial operation, re-check the strainer screen.

Chapter 3—Maintenance Procedures

⚠ ALL REPAIRS TO THE PUMP MUST BE PERFORMED BY QUALIFIED PERSONNEL IN A SAFE MANNER, UTILIZING TOOLS AND/OR EQUIPMENT THAT ARE FREE OF HAZARDS, AND FOLLOWS THE APPLICABLE SAFETY CODES OF PRACTICE SET BY THE LOCAL AUTHORITIES HAVING JURISDICTION. MAKE SURE THE SYSTEM PRESSURE HAS BEEN RELIEVED BEFORE ATTEMPTING ANY REPAIR TO THE PUMP.

A pump requires regular maintenance and care like all mechanical equipment. A neglected or improperly repaired pump will result in premature failure and cause unsafe conditions.

To promote product longevity and safety, maintenance must be performed by properly trained technicians. Make sure all safety systems are in place and the system pressure has been relieved before attempting ANY maintenance.

Make sure the transfer hoses are not “kinked” which can cause excessive pump discharge pressure. Always make sure your hoses are not out of date.

There are two lubrication points in which to grease the pump bearings; one zerk per bearing cap located at opposite ends of the pump. Four grease relief and seal ventilation fittings have been provided, two at each end of the pump, to prevent overgreasing the bearings. Overgreasing can cause seal failure if grease passageways are blocked in some way. Clean each fitting before lubricating the bearings. This practice helps to prevent foreign-material contamination of the bearings and accidental over-pressurization of the mechanical seals. Use only ball bearing grease (MIL-G-10924C) with a temperature rating of -50°F.

Normal wear parts are the mechanical shaft seals, bearings, vanes and sideplates. All of these parts plus O-rings and grease seals are offered in the Corken “repair kit” listed in this manual directly after the Seal Replacement Instruction on [page 10](#). Use only genuine Corken replacement parts when repairing the pump.

When it becomes necessary to repair your pump or remove it from the system, you must be absolutely certain that all propane, anhydrous ammonia or whatever product being pumped is bled from the pump and connecting piping. Once all the product has safely been bled from the pump and connecting piping, make certain no pressure is left in the system.

SPECIAL CARE MUST BE TAKEN DURING THE BLEED DOWN PROCESS TO AVOID DANGER TO PERSONNEL AND PROPERTY IN THE AREA. Bleeding a system too fast is a common mistake and may leave “refrigerated” liquid in the pump and piping even though the pressure gauge shows no pressure. As the “refrigerated” liquid begins to warm, more gas will escape causing a dangerous condition. Take your time in bleeding your system and make proper provisions to vent or capture the gas in accordance with local regulations. **ONLY A PROPERLY TRAINED INDIVIDUAL SHOULD BE ALLOWED TO BLEED A PUMPING SYSTEM.**

Pump Maintenance Schedule

	Daily	Monthly	Three Months
Lubricate bearings			X ¹
Inspect drive coupling			X
Clean inlet strainer		X	
Check for leaks	X		
Inspect hose and fittings	X		

¹ Continuous duty applications may require monthly lubrication.

Figure 3

If the pump’s use is seasonal, then special care must be taken during the off season to protect your pump from corrosion. If it is feasible and safe to keep the pump pressurized with product during the off season, this will prevent the entrance of any moisture or air. This system should be checked periodically to make certain all of the gas has not bled out.

If the pump is to be removed from service for some time, the pump must be protected., as propane, butane and anhydrous ammonia all leave the metal “bare” and open to corrosion. Piping and tanks not in service should also be protected, as the rust that forms can destroy the pump’s seals almost immediately after start-up. To prevent these problems, complete the following:

1. Fill or thoroughly flush the pump with a light rust inhibiting oil. If the pump is flushed with oil, placing some desiccant packets inside the pump will provide added protection.
2. Plug all pump openings.
3. Store in a dry location.
4. Before placing the pump back into service, drain the oil and remove any desiccant packets.
5. Before operating the pump, refer to chapter 2 of this manual for operation procedures.

3.1 Preventative Maintenance Procedures

Purpose

By following an effective preventive maintenance program, unscheduled downtime can be eliminated. This program should be used by the Operation Manager to get a maximum utilization of manpower and equipment as well as to prevent possible unsafe situations and/or production delays due to equipment breakdown.

Scope

The maintenance chart in figure 3 includes the items to be regularly checked and inspected with a recommended time schedule. These are basic maintenance recommendations, and each company should develop their own comprehensive preventive maintenance program schedule, tailor-made to their individual operational procedures and requirements.

Maintenance must only be performed by a properly trained and qualified individual following all the applicable safety procedures.

Procedures

Every procedure herein recommended must be performed in a safe manner (utilizing tools and/or equipment which are free of hazards) and following the safety codes of practice set by the authorities having jurisdiction. These are general guidelines and are not intended to cover all the safety aspects that must be considered and followed while performing these procedures.

1. Visual Inspection:

This includes checking for leaks, corroded areas, condition of hoses, piping and fittings, and any unsafe condition which may hinder the safety of the personnel and/or the facility.

2. Clean Inlet Strainer Screen:

A clogged strainer screen will create too much flow restriction and vapor will be formed causing the pump to cavitate. This reduces the pump's capacity and accelerates the wear of the internal parts.

3. Inspect Drive Coupling and Driveline:

Check the coupling alignment and the condition of the union for cuts, broken sections and wear.

4. Lubricate Pump Bearings:

Use only ball bearing grease, applied with a manual lubrication pump or gun. Always clean the grease openings thoroughly before greasing.

5. Lubricate Motor Bearing:

Follow the recommendations of the electric motor manufacturer for the type of grease to use and the lubrication frequency.

6. Performance Test:

a. While transferring liquid with the pump, check the pressure at the pump's inlet port. The pressure drop in the inlet piping should not be greater than 3 psi.

b. While transferring liquid with the pump, close the discharge valve(s) so the full flow will be directed back to the storage tank through the bypass valve. Then slowly close the valve downstream of the bypass valves. The discharge pressure of the pump should increase to the maximum differential pressure of the pump at no flow conditions (see [Appendix C—Performance Curves](#)).

c. If the maximum differential pressure is not obtained, the pump must be serviced. See [Appendix G—Troubleshooting Guide](#) for additional help.

d. Replace vanes or sideplates if worn.

7. Tighten all hold-down bolts.

8. Inspect motor starter contact points. This procedure must be performed by an authorized and qualified electrician according to the electric motor manufacturer's guidelines.

Chapter 4—Seal Replacement Instructions

For all models 521 and 1021.

Simple as A, B, C... but watch alignments A, B and C or your new seal will leak!

Caution: Bleed all pressure from the pump and piping before starting to install your seal assembly.

Cleanliness

Even the smallest amount of dirt on your new seal can cause early failure. Keep all parts, tools and your

hands clean while installing the seal. Never touch the smooth lapped faces of the carbon rotor or seal seat. With LP-Gas, anhydrous ammonia, and similar liquids, the fluid is 5 to 10 times thinner than water so the smooth/lapped surfaces of the new seal need to be as clean as possible.

Workmanship

This pump is a precision piece of equipment with very close clearances and should be treated with care. Never beat on it when inserting or removing parts.

Step 1

Depressurize and open the pump.

Remove the bearing cap and bearing housing. Should the bearing housing be rusted or frozen in place it may be necessary to remove the entire pump head. The housing can then be driven out gently with a block of wood.

Remove the old shaft O-ring and discard it. Never reuse an old O-ring except in an emergency. If you are also installing a new bearing or grease seal do so now.

Follow established safety regulations!

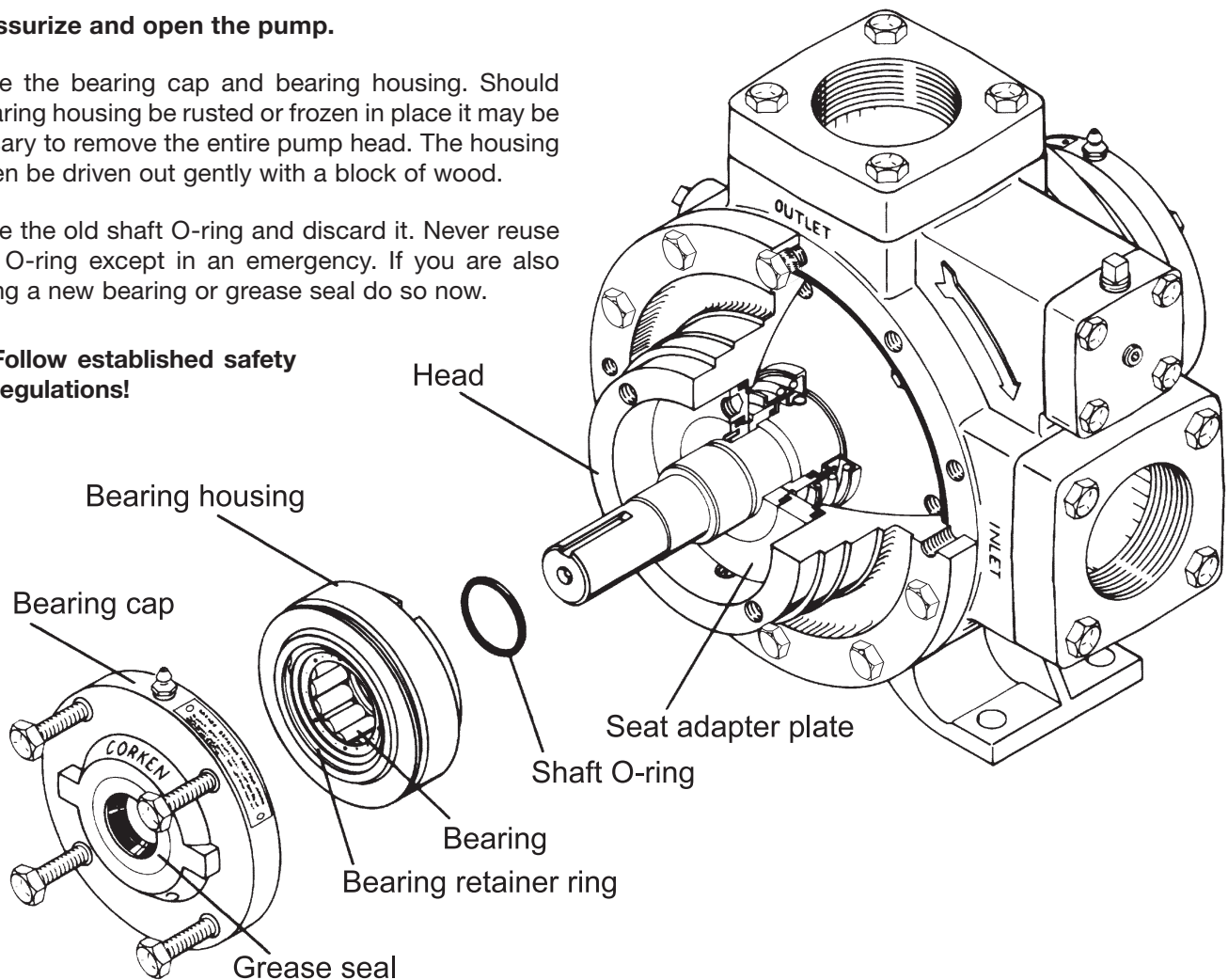

Step 2

Remove the old seal.

The seat adapter plate can be removed using a bearing cap bolt as a puller. Disregard the old adapter plate O-ring, seat, and seat O-ring. Remove and discard the rest of the old seal. Thoroughly clean all surfaces that contact O-rings. Use fine emery or crocus cloth. The shaft under the seal O-ring should be shiny smooth. Lubricate all surfaces with a clean, light oil. Do not let dirt settle on the parts.

 **Caution: Mechanical seals are precision devices. Care must be used when handling and installing the seal seat to prevent chipping or cracking.**

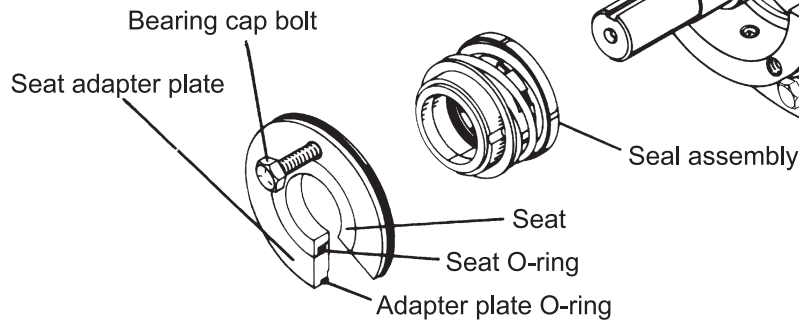

Step 3

Proper alignment of the new seal.

This is the most critical step of the seal installation. With clean hands unwrap the new seal without touching the seal faces.

- A. Locate the notch on the back of the retainer assembly and position over the shaft drive pin as shown in the illustration. If the shaft drive pin is not aligned with the notch, the seal will be improperly positioned and leak. It should not require any force to install the retainer assembly.

Hold the carbon rotor without touching the lapped face; lubricate the rotor O-ring with a light oil and install both on the pump shaft. (For the optional PTFE Coro-Seal installation, see the following paragraph.)

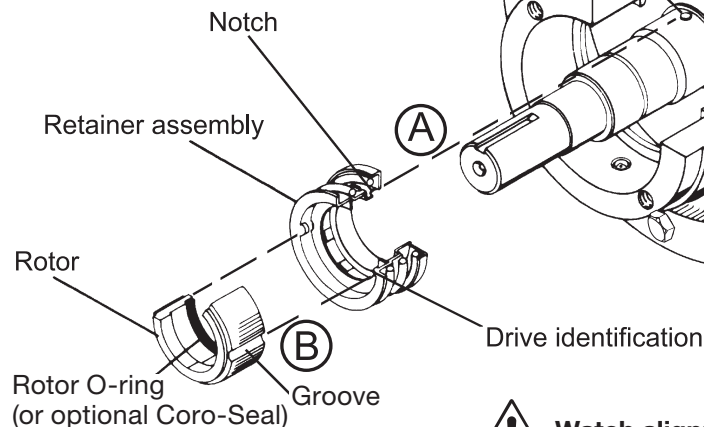

 **Watch alignments A and B!**

If you are using the optional PTFE Coro-Seal, make sure the shaft is very clean and smooth as the PTFE seal is not as tolerant of surface blemishes as rubber O-rings. After lubricating the Coro-Seal, install in the backside of carbon rotor with the spring toward you and slide the carbon rotor in position as previously described.

- B. The two grooves in the carbon rotor must line up with the drive indentations in the retainer assembly. If they do not, the seal will be improperly positioned and leak. Do not allow the carbon rotor to cock. This may chip the lapped face.

Step 4

Completing the installation.

After applying some oil to the new adapter plate O-ring, insert it into the pump head. Without touching the lapped face, insert the new seat and oiled seat O-ring into the adapter plate. Install the adapter plate in the pump head. Install the shaft O-ring on the shaft.

C. Slide the bearing housing over the shaft and install the bearing cap using a criss-cross method on the bolts and make sure the pump shaft turns freely.

 **Watch alignment C!**

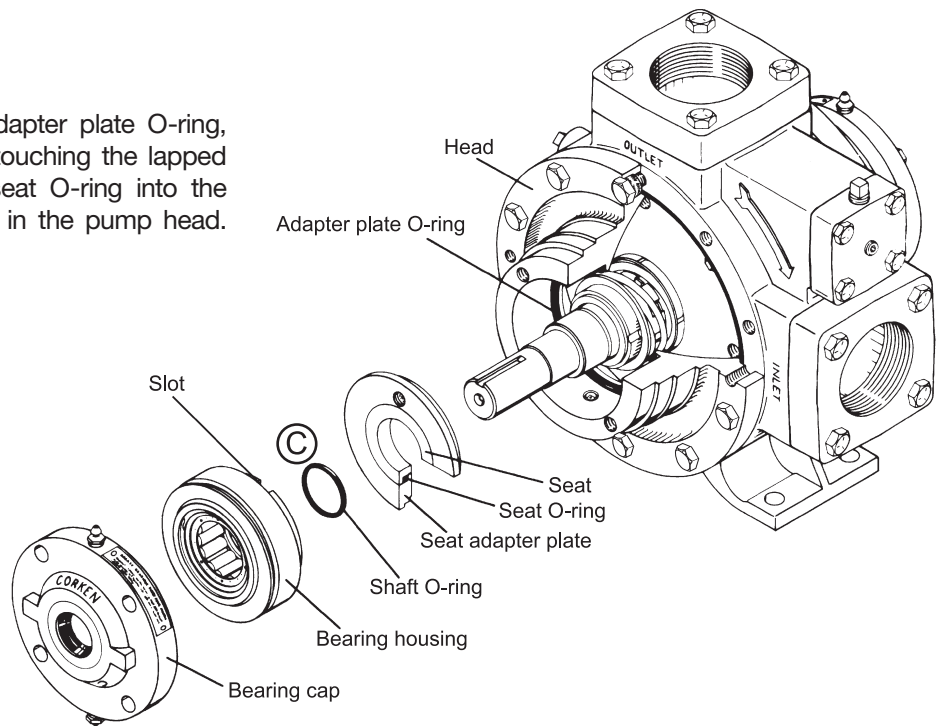

Step 5

Proper lubrication.

For proper lubrication, use MIL-G-10924C ball bearing grease only. Each pump is equipped with a grease zerk and relief fitting. Before greasing the bearing, the grease zerk and relief fitting must be cleaned thoroughly. If any dirt is forced through the grease zerk, early bearing failure will result.

Overgreasing will damage the pump bearings. To help prevent overgreasing, use a hand operated grease gun. Insert the grease slowly and stop as soon as the relief fitting opens. Excessive grease may drip out of the relief fitting for several hours after lubrication.

 **Do not overgrease!**

NOTE: When lubricating truck pumps, grease the U-joints and the spline of the drive shaft as well.

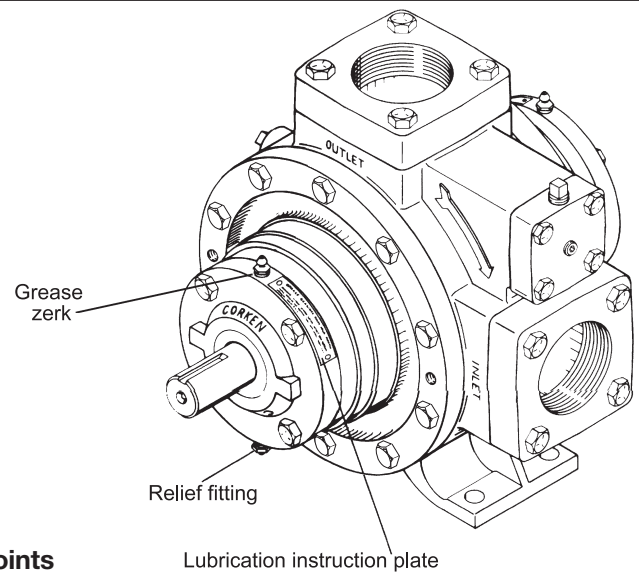

Step 6

Repressurize the system.

For best results slowly pressurize the pump with vapor before introducing liquid to the pump. When liquid enters a unpressurized pump—even slowly—it can sometimes refrigerate enough to keep the O-rings/elastomers from sealing properly and cause a leak.

 **Vapor first, then liquid!**

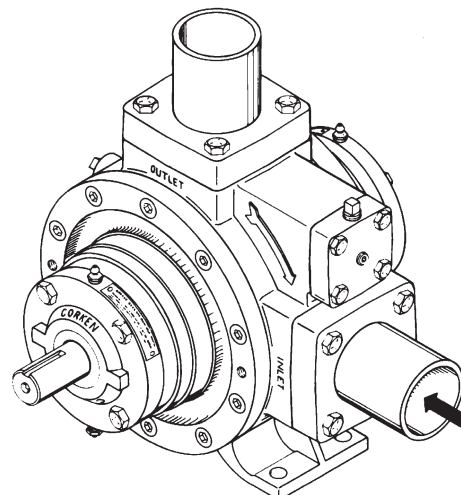

4.1 Repair Kits and Spare Parts for Sliding-Vane Pumps

D51 and F51 Standard Repair Parts (no kit available)

2296-1X_6 ^a	Seal assembly
2451-2	Vane
2-154_ ^a	Case O-ring
2491	Sideplate

D51 and F51 Additional Spare Parts^a

2492-X	Rotor and shaft assembly
2471	Roller bearing

521 Repair Kit 2904-X26^b

1163-2	Sideplate
1168-7	Vane
1358	Grease seal
1769-XRA6	Seal assembly (replacement)
2-112A	O-ring, Buna-N
2-224A	O-ring, Buna-N
2-227A	O-ring, Buna-N
2-234A	O-ring, Buna-N
2-261A	O-ring, Buna-N
2010	Flange gasket
2014	Grease seal, thrust
2754-X	Roller bearing

521 Additional Spare Parts^a

1166-1X1R	Rotor and shaft assembly
1162-2	Cam (liner)

1021 and F1021 Repair Kit 2906-X26^b

1209-1	Sideplate
1308-9	Vane
1358	Grease seal
1769-XRA6	Seal assembly (replacement)
2-112A	O-ring, Buna-N
2-228A	O-ring, Buna-N
2-245A	O-ring, Buna-N
2-249A	O-ring, Buna-N
2-268A	O-ring, Buna-N
2014	Grease seal, thrust
2754-X	Roller bearing

1021 and F1021 Additional Spare Parts^a

1208-1X1R	Rotor and shaft assembly
1201-2	Cam (liner)

^a For a complete list of parts and O-rings, see parts details in [Appendix E](#).
^b All repair kits have Buna-N O-rings which are suitable for both LPG and NH₃ applications.

Appendix A—Model Number Identification Code

Models D51 and F51

Product Description

D51 Bare pump with mounting bracket and flexible coupling to close couple the pump to any NEMA 56 or 66 C-face motor (Note motor is not included).

F51 Frame mounted pump for baseplate mounting (bare pump only).

Base Model #	D51	F51
Inlet	1" NPT	1" NPT
Outlet	3/4" NPT	3/4" NPT
Weight bare pump lbs. (kg)	40 (18.1)	25 (11.3)

Model Number
Base X X X X

Specification Fields

Pump	Iron	Standard	A
Vanes	Carbon	Standard	D
O-ring Material	Buna-N	Standard	A
	Neoprene ^{®1}	No charge option	B
Seal Seat Material	Silicon carbide	Standard	6

Mounting Options

Part Number	Model Reference	Maximum Motor Frame Size	Ship Weight lb (kg) Mounting Only	Mounting Option
101-12	F51 only	145T	25 (11.3)	Mounting for frame mounted pump (F51) mounting includes steel baseplate and direct drive through flexible coupling.

¹ Registered trademark of the DuPont company.

Appendix A—Model Number Identification Code and Available Options

Models 521, 1021, and F1021

Base Model #	521	1021	F1021
Inlet	2-1/2" NPT	3" NPT	3" ANSI 300 lb
Outlet	2" NPT	3" NPT	2-1/2" ANSI 300 lb
Weight bare pump lb (kg)	132 (60)	200 (91)	200 (91)

Model Number
Base X X X X X X

Specification Fields

Blade Type	10 blades	Standard	E
Blade Material	GCB-50	Standard	G
O-ring Material	Buna-N	Standard	A
	Neoprene ^{®1}	No charge option	B
Seal Seat Material	Silicon carbide	Standard	6

Flange Options

WF=Slip on weld flange All ANSI flanges are 300 lb. • = Available option "Blank" = Not available

Inlet Flange

Standard	2-1/2" NPT	•		J
	3" NPT		•	M
	3" ANSI			P
	4" ANSI			S
No Cost	2" NPT	•		E
	4" NPT		•	Q
Extra Cost	2" WF	•		F
	2-1/2" WF	•		K
	3" WF		•	N
	4" WF		•	R

Outlet Flange

Standard	2" NPT	•		E
	3" NPT		•	M
	2-1/2" ANSI			L
	3" ANSI			P
No Cost	1-1/2" NPT	•		C
	2-1/2" NPT	•		J
	4" NPT		•	Q
Extra Cost	1-1/2" WF	•		D
	2" WF	•		F
	2-1/2" WF	•		K
	3" WF		•	N
	4" WF		•	R

Mounting Options

Part Number	Model Reference	Maximum Motor Frame Size	Ship Weight lb (kg) Mounting Only	Mounting Option
103-9-	521	245T	422 (191)	Mounting set up for V-belt drive. Includes steel baseplate, adjustable motor slide base, V-belt drive, and enclosed belt guard.
103-10-	1021 and F1021	284T	560 (254)	
102-	All		Consult Factory	Mounting set up for use with engine driver through V-belt includes steel baseplate, flexible coupling and guard
101GRB-	All	254T	Consult Factory	Mounting set up for direct drive. Includes size B gear reducer, steel baseplate, reducer bracket, couplings, and coupling guard.
101GRC-	All	324T	Consult Factory	Mounting set up for direct drive. Includes size C gear reducer, steel baseplate, reducer bracket, couplings, and coupling guard.

¹ Registered trademark of the DuPont company.

Appendix B—Specifications for Models D51 and F51

Operating Specifications

Minimum RPM:	1450
Maximum RPM:	1750
Minimum temperature:	-25°F (-32°C)
Maximum temperature:	225°F (107°C)
Maximum working pressure:	350 psig (24.1 bar g)
Maximum differential pressure:	125 psi (8.6 bar d)
Maximum driver size:	2 hp (1.5 kW)
Flow range:	1–6 gpm (4–23 L/min)

Material Specifications

Part	Model	Material
Case, head rotor	All	Ductile iron ASTM A536
Sideplate	All	Gray iron ASTM A48, Class 30
Seal seat	All	Silicon carbide
Seal rotor	All	Carbon
Seal metal parts	All	Steel
Vanes	All	Carbon
Relief valve springs	All	Steel, cadmium plated
Relief valve	All	Steel
Shaft	All	“Stressproof” steel
Mounting bracket	D51	Gray iron ASTM A48, Class 30
Base	F51	Steel
O-rings	All	Buna-N (standard), PTFE (optional), Viton ^{®1} (optional), Neoprene ^{®1} (optional)
Relief valve adjusting stem seal	All	Buna-N
Retainer rings	All	Steel
Bearings	All	Cylindrical roller

¹ Registered trademark of the DuPont company.

Appendix B—Specifications for Models 521, 1021, and F1021

Operating Specifications

Model	521	1021	F1021
RPM range	420–950	420–950	420–950
Temperature range	-25°F (-32°C) to 225°F (107°C)		
Maximum working pressure psig (bar g)	350 (24.1)	350 (24.1)	350 (24.1)
Maximum differential pressure psid (bar d)	125 (8.6)	125 (8.6)	125 (8.6)
Maximum driver size hp (kW)	10 (7.5)	20 (15)	20 (15)
Flow range gpm	30–85	65–195	65–195

Flange Options

Model		Standard	No Cost Option	Extra Cost Option
521	Inlet	2-1/2" NPT	2" NPT	2", 2-1/2" weld flange
	Outlet	2" NPT	1-1/2", 1-1/1" NPT	1-1/2", 2", 2-1/2" weld flange
1021	Inlet	3" NPT	4" NPT	3", 4" weld flange
	Outlet	3" NPT	4" NPT	3", 4" weld flange
F1021	Inlet	3" 300# ANSI	—	—
	Outlet	2-1/2" 300# ANSI	—	—

Material Specifications

Part	Model	Standard Material
Case, head, flange, rotor, seat adapter plate	All	Ductile iron ASTM A536, Class 30
Cam, sideplate, bearing cap	All	Gray iron ASTM A48, Class 30
Welding flange	All	Steel
Seal seat	All	Silicon carbide
Seal metal parts	All	Steel
Shaft	521, 1021	"Stressproof" steel
Vanes	All	Plastic
Relief valve spring	521, 1021	Steel, cadmium plated
Relief valve	521, 1021	Steel
Bearing	All	Cylinder roller
O-rings	All	Buna-N (standard), PTFE (optional), Viton ^{®1} (optional), Neoprene ^{®1} (optional)
Retainer rings	All	Steel

¹ Registered trademark of the DuPont company.

Appendix C—Performance Curves for Models D51 and F51

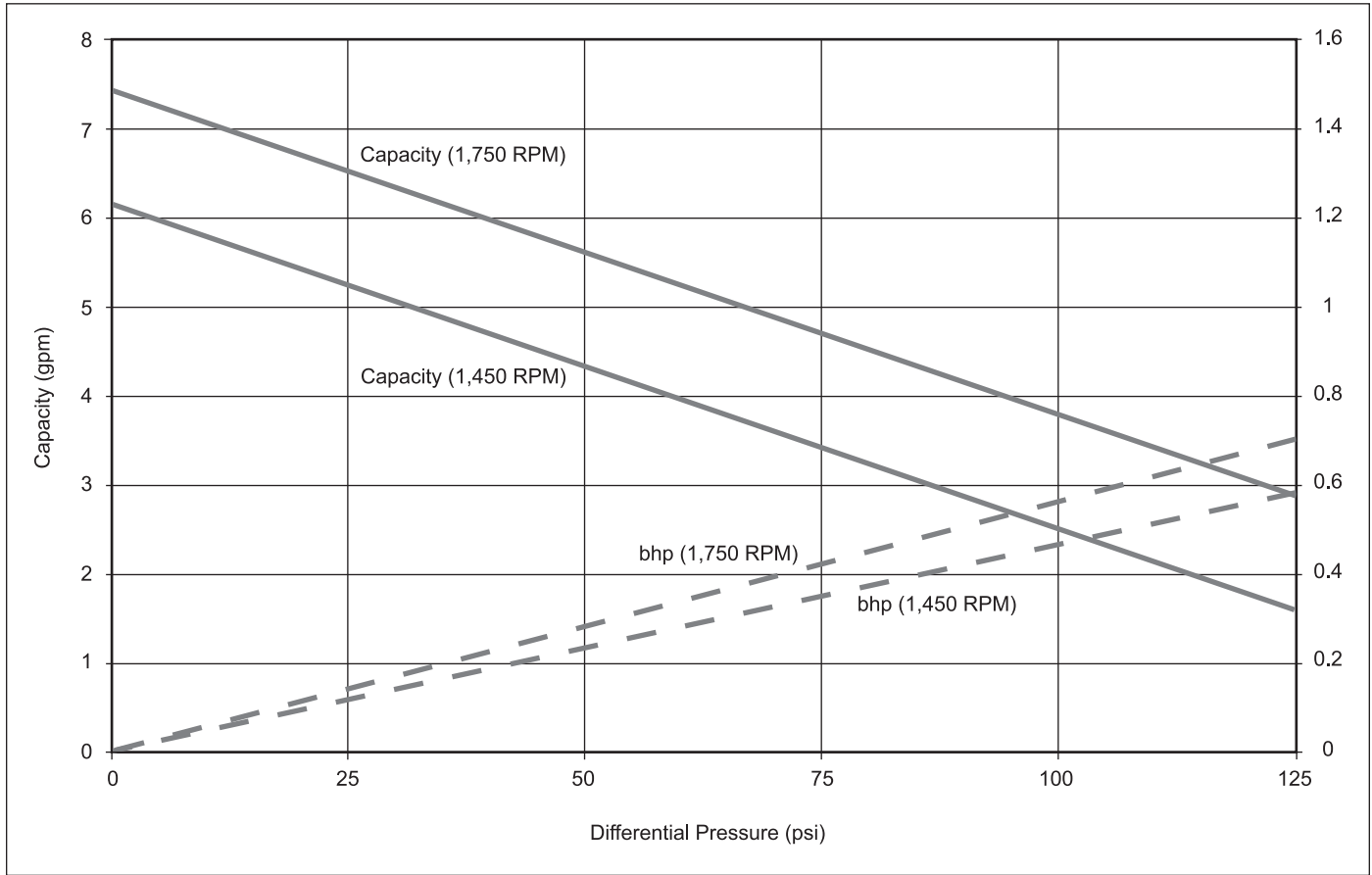

Appendix C—Performance Curves for Model 521

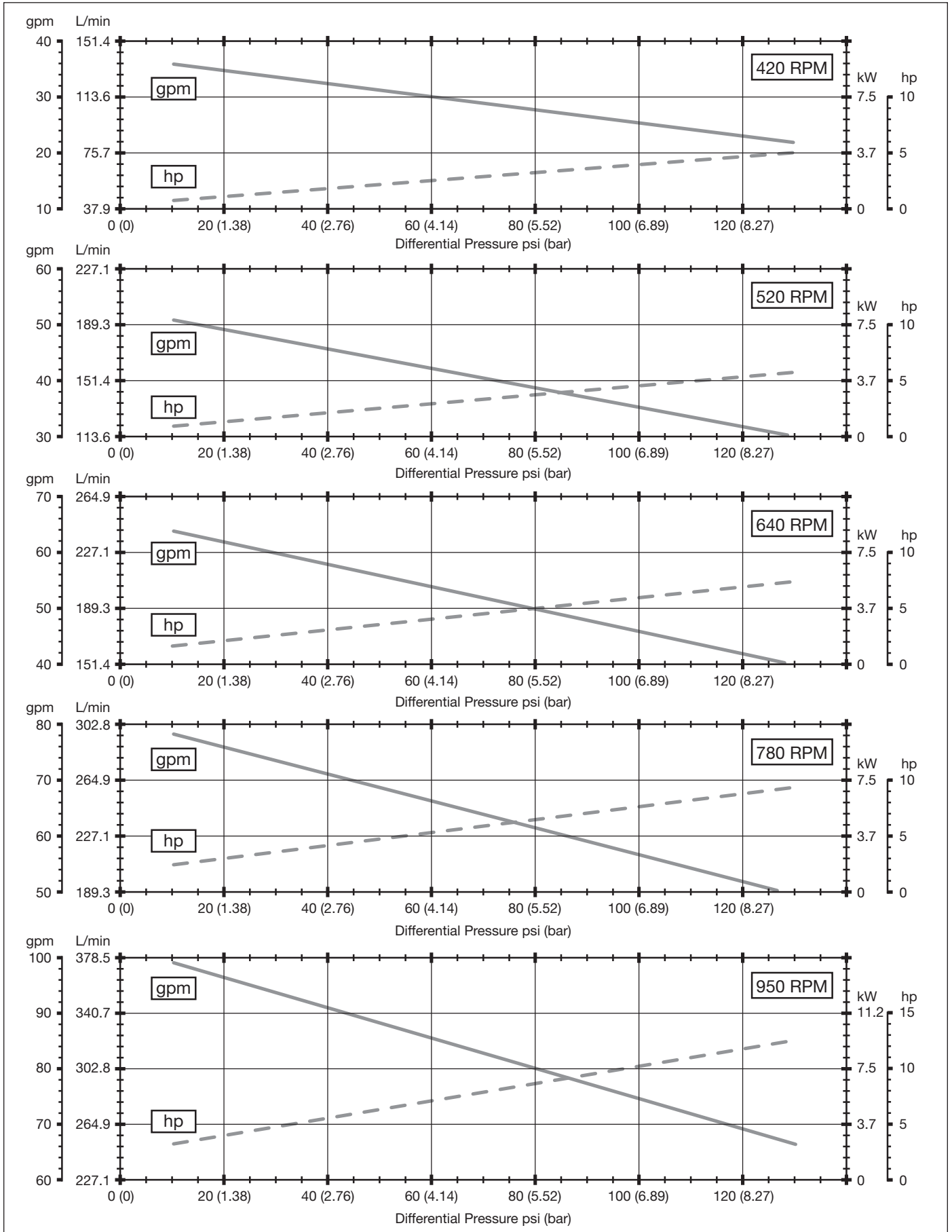

Appendix C—Performance Curves for Model 1021

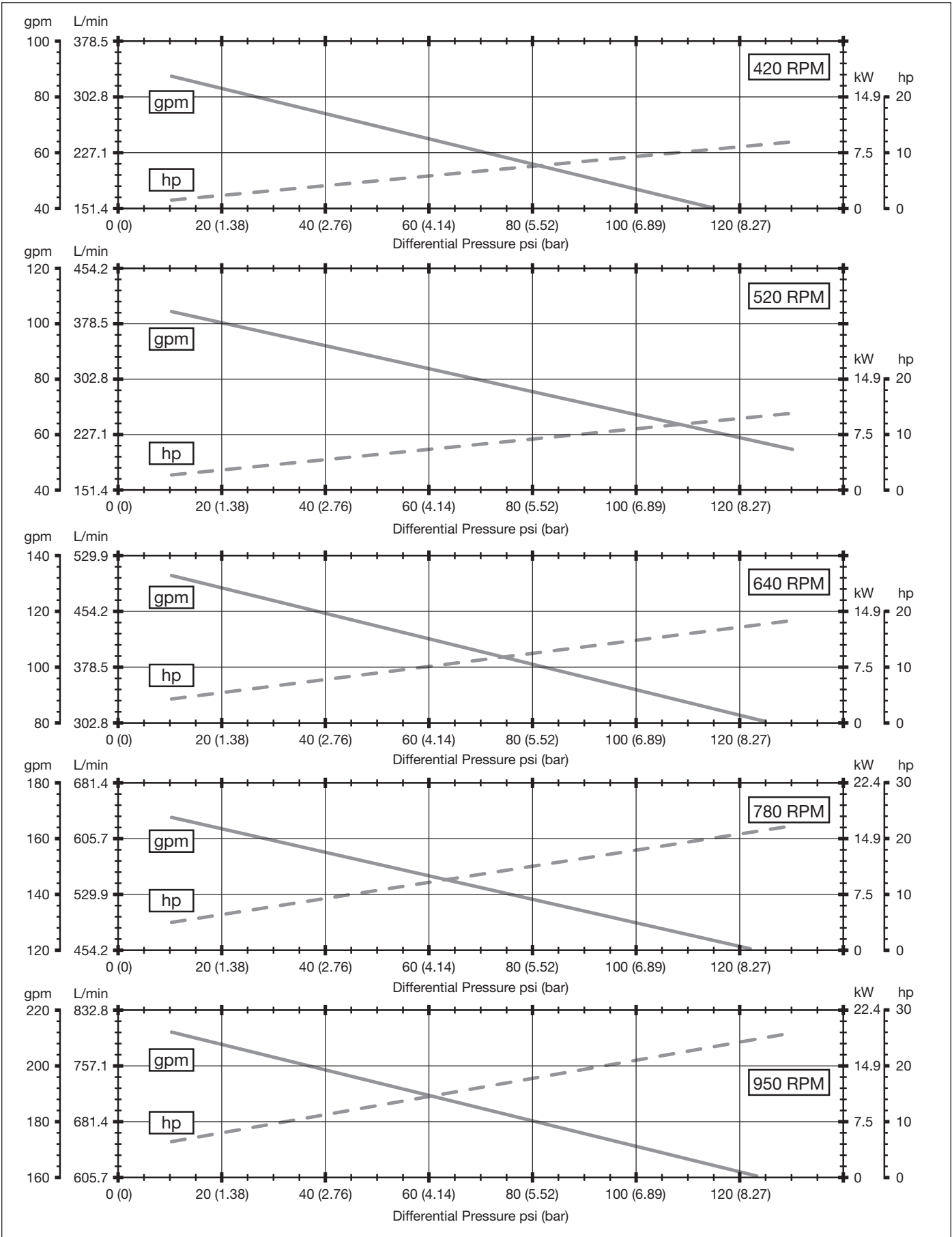

Appendix D—Outline Dimensions for Model F51-101 (Frame Mount)

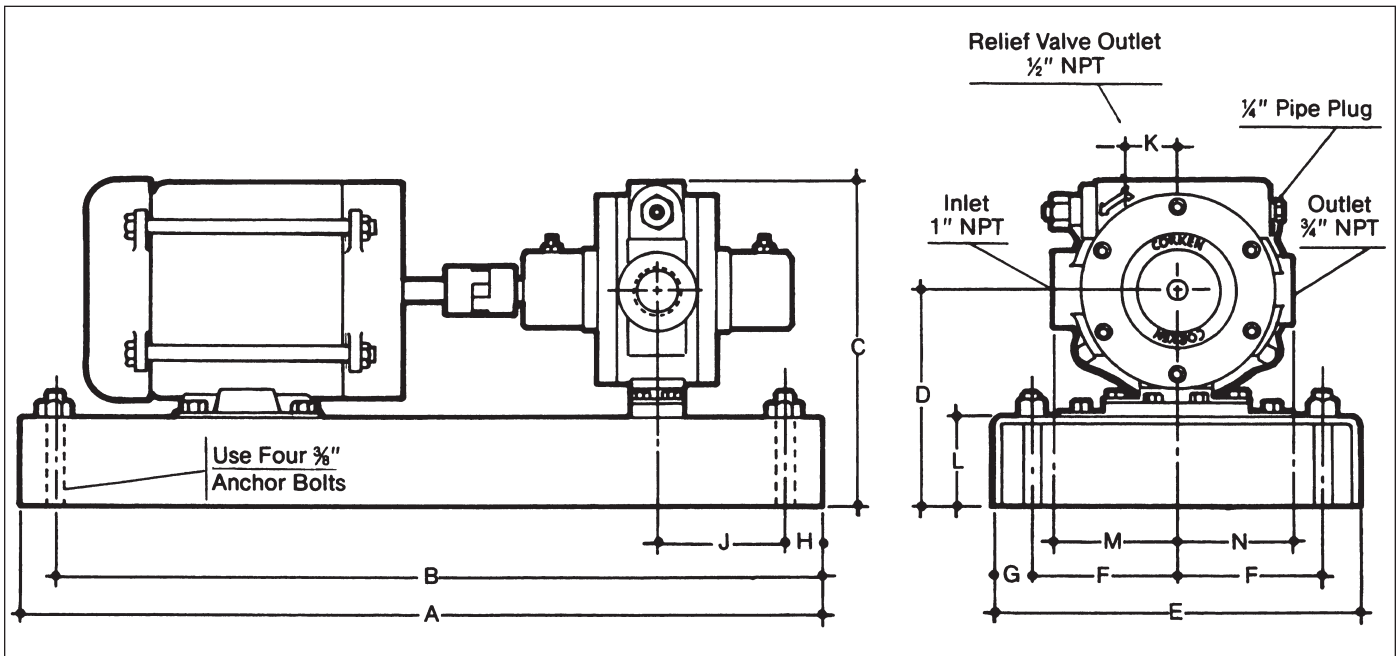

A	B	C	D	E	F	G	H	J	K	L	M	N
22 (55.90)	20 (50.80)	9 (22.90)	6 (15.20)	10 (25.40)	4 (10.20)	1 (2.54)	1 (2.54)	3-1/2 (8.89)	1-7/16 (3.65)	2-1/2 (6.35)	3-3/8 (8.57)	3-3/16 (8.10)

All dimensions are in inches (centimeters).

Appendix D—Outline Dimensions for Models 521 and 1021

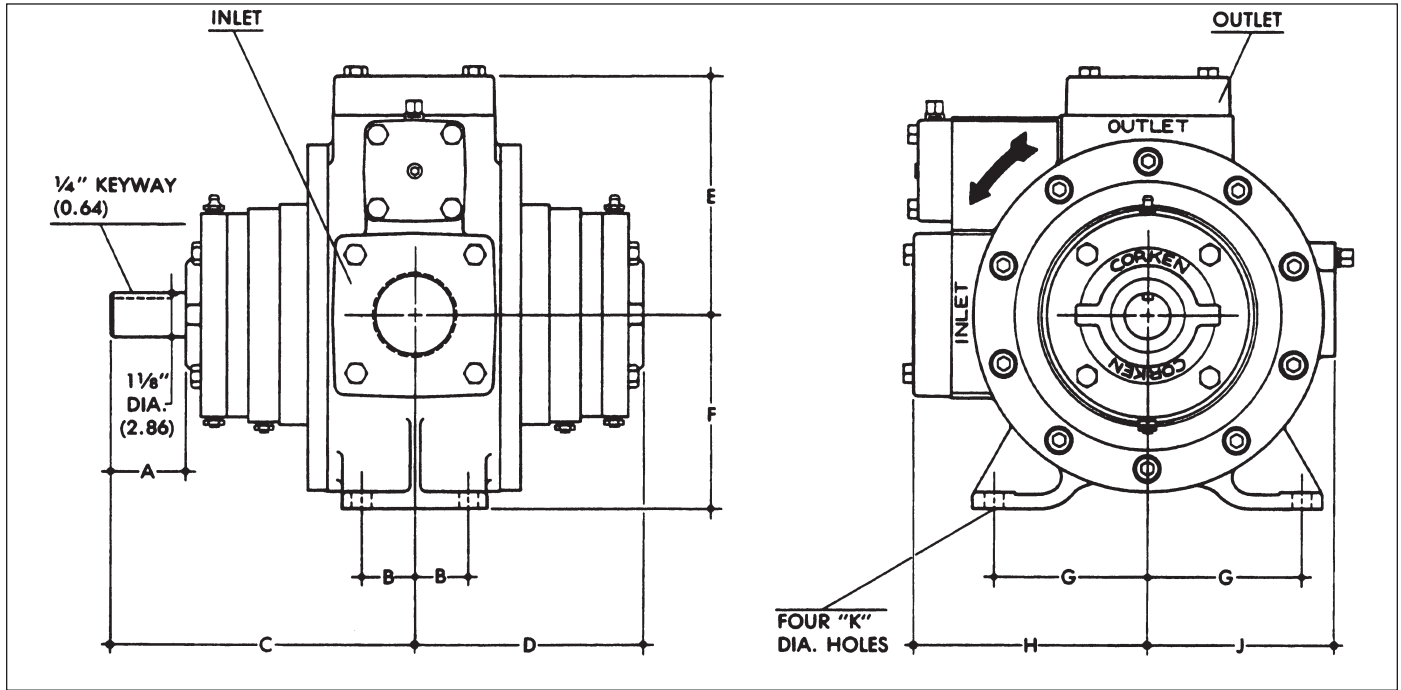

Model	Inlet	Outlet	A	B	C	D	E	F	G	H	J	K
521	STD: 2-1/2" NPT OPT: 2" NPT 2", 2-1/2" Weld	STD: 2" NPT OPT: 1-1/2", 2-1/2" NPT 1-1/2", 2", 2-1/2" Weld	1-31/32 (5.00)	1-3/8 (3.49)	7-7/8 (20.00)	5-29/32 (15.00)	6-1/8 (15.56)	5 (12.70)	4 (10.16)	6-1/8 (15.56)	4-11/16 (11.91)	1/2 (1.27)
1021	STD: 3" NPT OPT: 4" NPT 3", 4" Weld	STD: 3" NPT OPT: 4" NPT 3", 4" Weld	2 (5.08)	1-3/4 (4.45)	8-1/2 (21.59)	6-7/16 (16.35)	7-1/16 (17.94)	5-1/2 (13.97)	4-1/8 (10.48)	7-1/16 (17.94)	5-3/8 (13.65)	1/2 (1.27)

All dimensions are in inches (centimeters).

Appendix D—Outline Dimensions for Models F1021

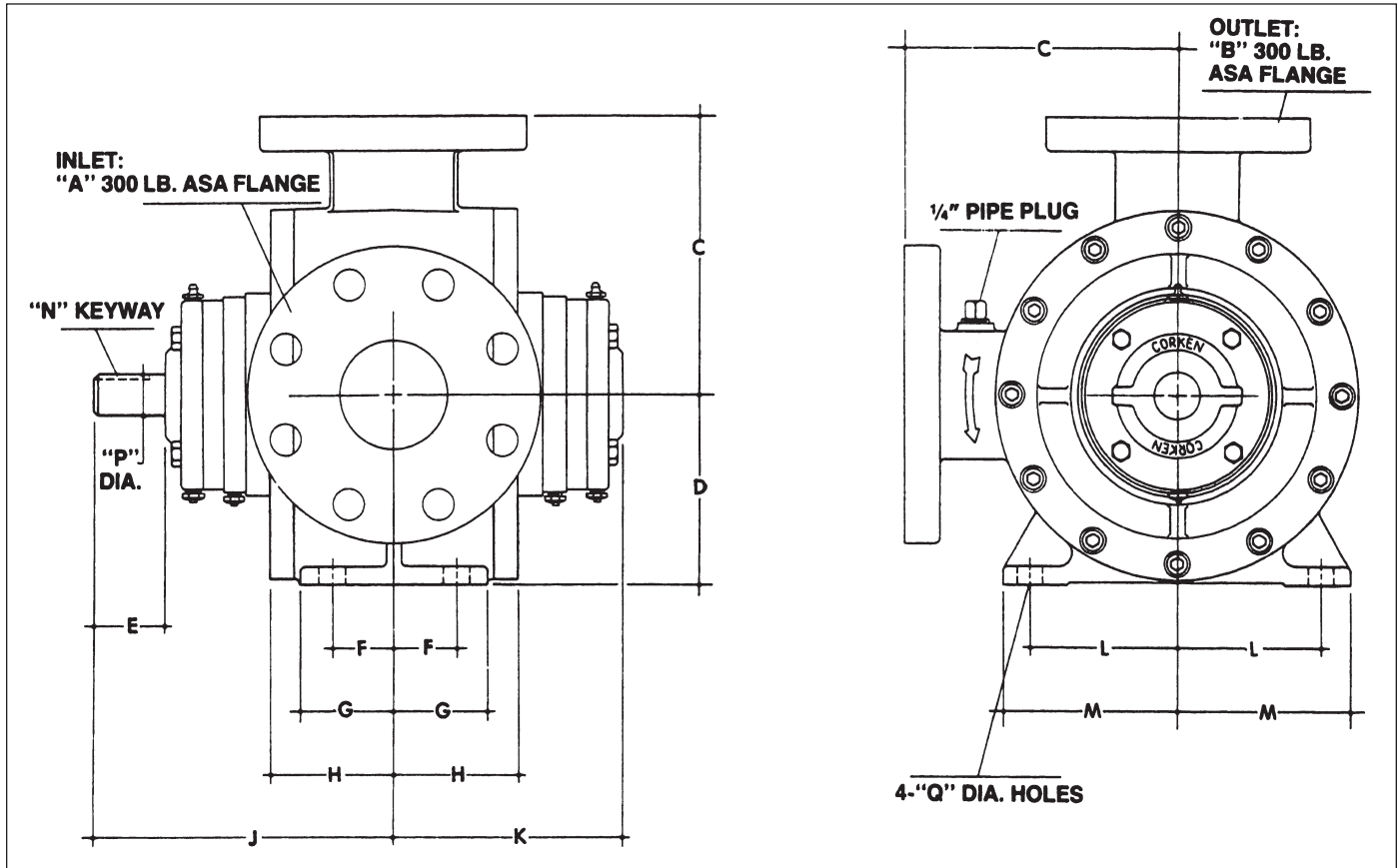

Model	A	B	C	D	E	F	G	H	J	K	L	M	N	P	Q
F1021	3	2-1/2	7-3/4 (19.70)	5-1/2 (14.00)	2 (5.10)	1-3/4 (4.40)	2-5/8 (6.70)	3-1/2 (8.90)	8-1/2 (21.60)	6-1/2 (16.50)	4-1/8 (10.50)	4-15/16 (12.50)	1/4 (0.64)	1-1/8 (2.90)	1/2 (1.27)

All dimensions are in inches (centimeters).

Appendix D—Outline Dimensions for Models 521 and 1021-103

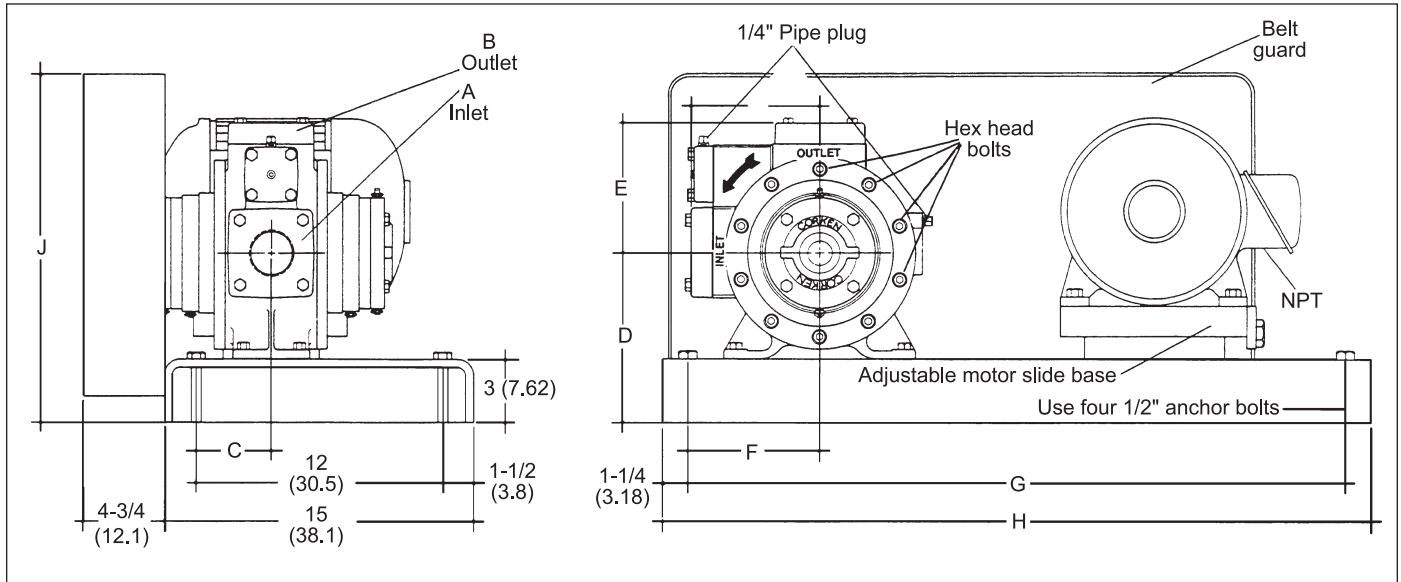

Flange Dimensions

Model	A (inlet)	B (outlet)
521	Standard: 2-1/2" NPT	Standard: 2" NPT
	Optional: 2" NPT	Optional: 1-1/2", 2-1/2" NPT
1021	Standard: 3" NPT	Standard: 3" NPT
	Optional: 4" NPT	Optional: 4" NPT

521-103 Dimensions

Motor		Pump Speed	C	D	E	F	G	H	J
Hp	Frame ¹								
2	145T	All	3-5/8 (9.21)	8 (20.30)	6-1/8 (15.60)	6-1/4 (15.90)	31-1/2 (80.00)	34 (86.40)	16-1/2 (41.90)
2	182T	All	3-5/8 (9.21)	8 (20.30)	6-1/8 (15.60)	6-1/4 (15.90)	31-1/2 (80.00)	34 (86.40)	16-1/2 (41.90)
3	182T	All	3-5/8 (9.21)	8 (20.30)	6-1/8 (15.60)	6-1/4 (15.90)	31-1/2 (80.00)	34 (86.40)	16-1/2 (41.90)
3	184T	All	3-5/8 (9.21)	8 (20.30)	6-1/8 (15.60)	6-1/4 (15.90)	31-1/2 (80.00)	34 (86.40)	16-1/2 (41.90)
5	184T	All	3-5/8 (9.21)	8 (20.30)	6-1/8 (15.60)	6-1/4 (15.90)	31-1/2 (80.00)	34 (86.40)	16-1/2 (41.90)
7-1/2	213T	All	3-5/8 (9.21)	8 (20.30)	6-1/8 (15.60)	6-1/4 (15.90)	31-1/2 (80.00)	34 (86.40)	16-1/2 (41.90)
10	215T	420-470	3-5/8 (9.21)	10-3/4 (27.30)	6-1/8 (15.60)	9-1/4 (23.50)	39-1/2 (100.30)	42 (106.70)	19-3/4 (50.20)
10	215T	520-950	3-5/8 (9.21)	8 (20.30)	6-1/8 (15.60)	6-1/4 (15.90)	31-1/2 (80.00)	34 (86.40)	16-1/2 (41.90)

1021-103 Dimensions

Motor		Pump Speed	C	D	E	F	G	H	J
Hp	Frame ¹								
3	182T	All	4-1/2 (10.80)	8-1/2 (21.60)	7-3/16 (18.30)	6-1/4 (15.90)	31-1/2 (80.00)	34 (86.40)	16-1/2 (41.90)
3	182T	All	4-1/2 (10.80)	8-1/2 (21.60)	7-3/16 (18.30)	6-1/4 (15.90)	31-1/2 (80.00)	34 (86.40)	16-1/2 (41.90)
5	184T	All	4-1/2 (10.80)	8-1/2 (21.60)	7-3/16 (18.30)	6-1/4 (15.90)	31-1/2 (80.00)	34 (86.40)	16-1/2 (41.90)
7-1/2	213T	All	4-1/2 (10.80)	8-1/2 (21.60)	7-3/16 (18.30)	6-1/4 (15.90)	31-1/2 (80.00)	34 (86.40)	16-1/2 (41.90)
10	215T	420-470	4-1/2 (10.80)	10-1/2 (26.70)	7-3/16 (18.30)	9-1/4 (23.50)	39-1/2 (100.30)	42 (106.70)	19-3/4 (50.20)
10	215T	520-950	4-1/2 (10.80)	8-1/2 (21.60)	7-3/16 (18.30)	6-1/4 (15.90)	31-1/2 (80.00)	34 (86.40)	16-1/2 (41.90)
15	254T	420-520	4-1/2 (10.80)	10-1/2 (26.70)	7-3/16 (18.30)	9-1/4 (23.50)	39-1/2 (100.30)	42 (106.70)	19-3/4 (50.20)
15	254T	580-950	4-1/2 (10.80)	8-1/2 (21.60)	7-3/16 (18.30)	6-1/4 (15.90)	31-1/2 (80.00)	34 (86.40)	16-1/2 (41.90)
20	256T	520	4-1/2 (10.80)	10-1/2 (26.70)	7-3/16 (18.30)	9-1/4 (23.50)	39-1/2 (100.30)	42 (106.70)	19-3/4 (50.20)
20	256T	640-950	4-1/2 (10.80)	8-1/2 (21.60)	7-3/16 (18.30)	6-1/4 (15.90)	31-1/2 (80.00)	34 (86.40)	16-1/2 (41.90)

¹ All dimensions based on a motor speed of 1,750 RPM.

All dimensions are in inches (centimeters).

Appendix D—Outline Dimensions for Models F1021

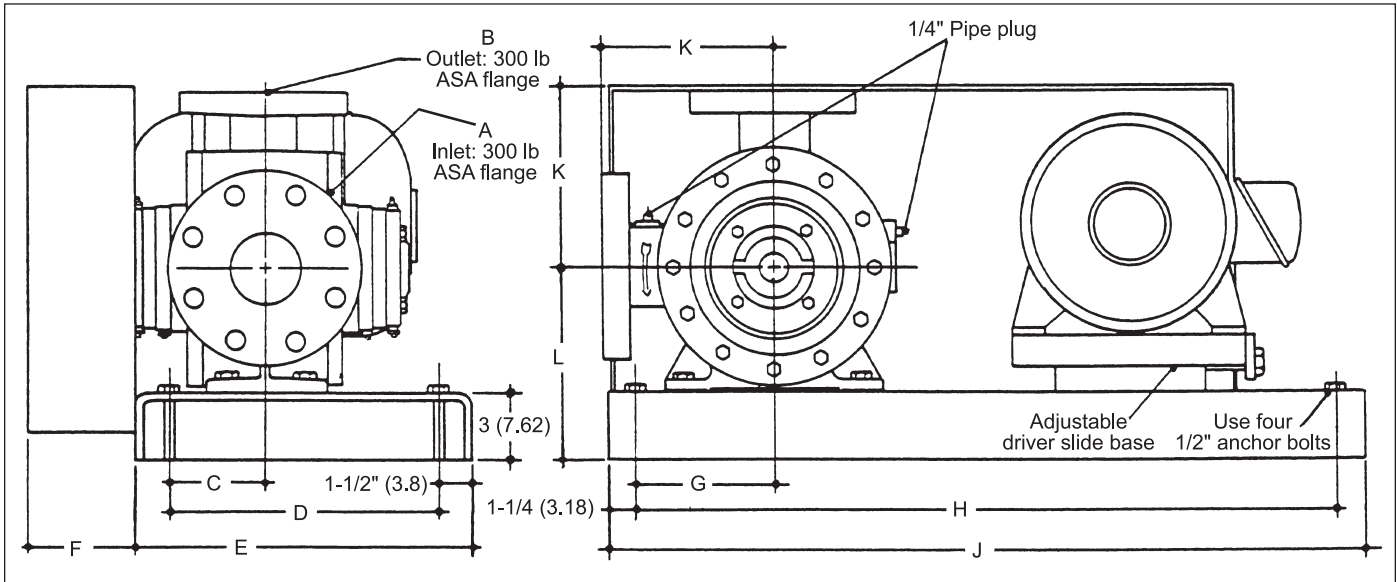

Flange Dimensions

Model	A (inlet)	B (outlet)
F1021	3" 300# ANSI	2-1/2" 300# ANSI

F1021-103 Dimensions

Motor		Pump Speed	C	D	E	F	G	H	J	K	L
Hp	Frame ¹										
3	182T	All	4-1/4 (10.80)	12 (30.50)	15 (38.10)	5 (12.70)	6-1/4 (15.90)	31-1/2 (80)	34 (86.40)	7-3/4 (19.70)	8-1/2 (21.60)
3	182T	All	4-1/4 (10.80)	12 (30.50)	15 (38.10)	5 (12.70)	6-1/4 (15.90)	31-1/2 (80)	34 (86.40)	7-3/4 (19.70)	8-1/2 (21.60)
5	184T	All	4-1/4 (10.80)	12 (30.50)	15 (38.10)	5 (12.70)	6-1/4 (15.90)	31-1/2 (80)	34 (86.40)	7-3/4 (19.70)	8-1/2 (21.60)
7-1/2	213T	All	4-1/4 (10.80)	12 (30.50)	15 (38.10)	5 (12.70)	6-1/4 (15.90)	31-1/2 (80)	34 (86.40)	7-3/4 (19.70)	8-1/2 (21.60)
10	215T	420-470	4-1/4 (10.80)	12 (30.50)	15 (38.10)	5 (12.70)	9-1/4 (23.50)	39-1/2 (100.30)	42 (106.70)	7-3/4 (19.70)	10-1/2 (26.70)
10	215T	520-950	4-1/4 (10.80)	12 (30.50)	15 (38.10)	5 (12.70)	6-1/4 (15.90)	31-1/2 (80)	34 (86.40)	7-3/4 (19.70)	8-1/2 (21.60)
15	254T	420-520	4-1/4 (10.80)	12 (30.50)	15 (38.10)	5 (12.70)	9-1/4 (23.50)	39-1/2 (100.30)	42 (106.70)	7-3/4 (19.70)	10-1/2 (26.70)
15	254T	580-950	4-1/4 (10.80)	12 (30.50)	15 (38.10)	5 (12.70)	6-1/4 (15.90)	31-1/2 (80)	34 (86.40)	7-3/4 (19.70)	8-1/2 (21.60)
20	256T	520	4-1/4 (10.80)	12 (30.50)	15 (38.10)	5 (12.70)	9-1/4 (23.50)	39-1/2 (100.30)	42 (106.70)	7-3/4 (19.70)	10-1/2 (26.70)
20	256T	640-950	4-1/4 (10.80)	12 (30.50)	15 (38.10)	5 (12.70)	6-1/4 (15.90)	31-1/2 (80)	34 (86.40)	7-3/4 (19.70)	8-1/2 (21.60)

¹ All dimensions based on a motor speed of 1,750 RPM.

Appendix E—Parts Details for Seal Assembly (2296 Series)

Models D51 and F51

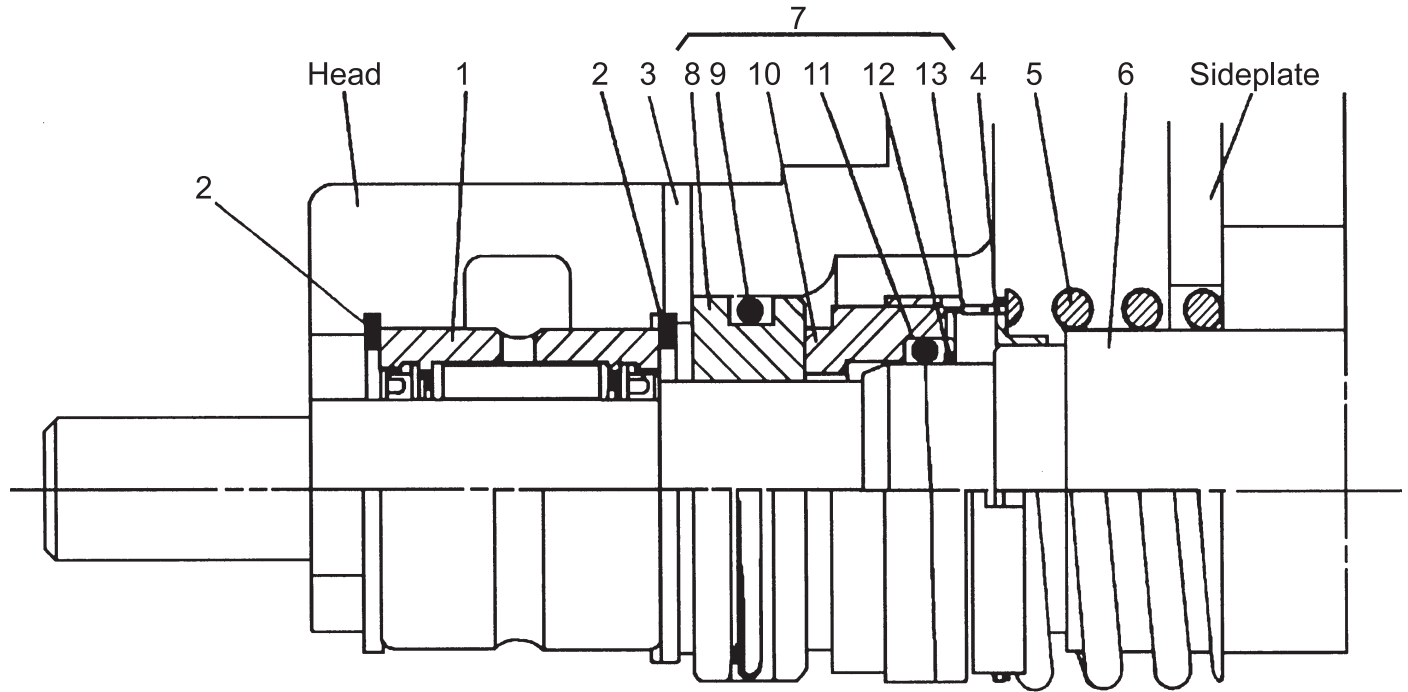

Ref No.	Part No.	Description	Qty.
1.	2471	Roller bearing	1
2.	5000-112	Retainer ring	1
3.	2595	Seat location pin	1
4.	2735	Drive band (with 2492-X)	1
5.	3471	Spring (with 2492-X)	1
6.	2492-X	Rotor and shaft assembly	1
7.	2296-X_6 ^{a, b}	Seal	1
	2296-1X_6 ^{a, b}	Seal Assembly	1
8.	Not sold separately ^c	Silicon carbide seal seat	1
9.	Not sold separately ^c	Seat O-ring	1
10.	Not sold separately ^c	Rotor	1
11.	Not sold separately ^c	O-ring	1
12.	Not sold separately ^c	Disc	1
13.	Not sold separately ^c	Retainer	1

Material Code	
A	Buna-N
B	Neoprene ^{®d}



CAUTION: Always relieve pressure in the unit before attempting any repairs.

^a _ denotes material code. See material code chart for details.

^b Seal assembly includes the seal and a 2-154_^a case O-ring.

^c Not sold separately. These items are included in both the seal and the seal assembly.

^d Registered trademark of the DuPont company.

Appendix E—Parts Details for Model D51 (Direct Mount)



CAUTION: Always relieve pressure in the unit before attempting any repairs.

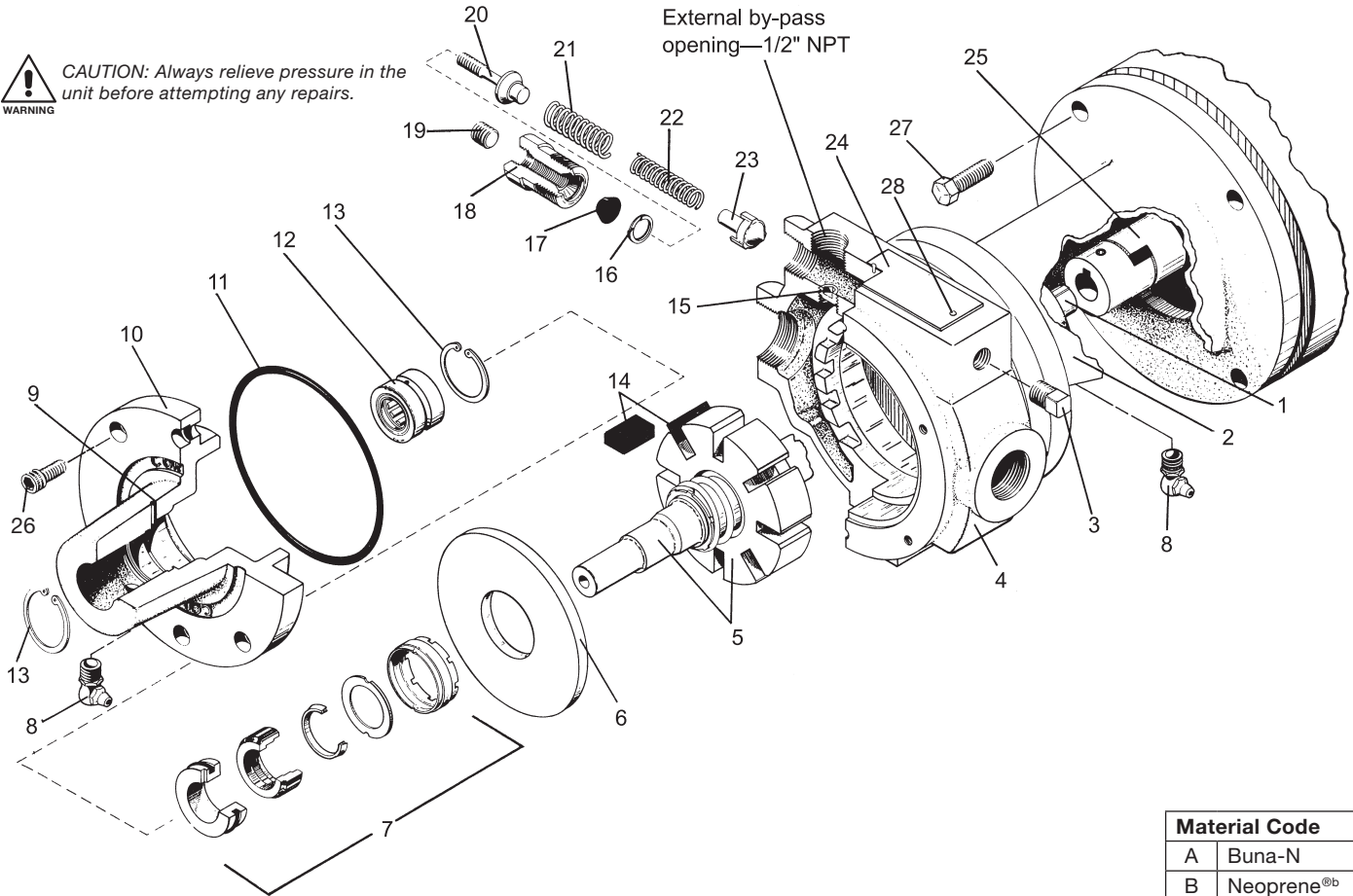

Material Code	
A	Buna-N
B	Neoprene ^{®b}

Ref No.	Part No.	Description	Qty.
1.	2592	Key—1/8" sq. x 9/16"	1
2.	2510	Mounting bracket	1
3.	3442	Pipe plug—1/4" NPT	1
4.	2468	Case	1
5.	2492-X	Rotor and shaft assembly	1
6.	2491	Sideplate	2
7.	2296-1X_6 ^a	Seal assembly	2
8.	2604	Elbow grease zerk—1/8" NPT	2
	2159	Lubricap #2 (not shown)	2
9.	2595	Seat location pin	2
10.	2472	Head	2
11.	2-154 ^a	Case O-ring	2
12.	2471 ^d	Roller bearing	2
13.	5000-112	Retainer ring	4
14.	2451-2	Carbon vane	8
15.	2590 ^c	Flush plug—1/8" NPT	1
16.	2760-53	Retainer ring	1
17.	2589	Stem seal	1
18.	2585	Relief valve plug	1
19.	2590	Flush plug—1/8" NPT	1
20.	2584-X	Adjusting stem assembly	1
21.	2587 ^c	Outer relief valve spring	1
22.	2586 ^c	Inner relief valve spring	1
23.	2588	Relief valve	1
24.	2591	Nameplate	1
25.	2593-1	Coupling with spider	1
	2774	Coupling spider only	1

Ref No.	Part No.	Description	Qty.
26.	7002-025NC062A	Bolt socket head	9
27.	7001-037NC100A	Bolt hex head	4
28.	7012-006SF019E	Nameplate screw	2

^a _ denotes material code. See material chart for details.

^b Registered trademark of the DuPont company.

^c The pump relief valve is installed at the factory to operate as an external bypass through the 1/2" NPT hole back to the storage tank. To change from this external configuration to an internal relief valve, remove relief valve plug 2585 and relief valve springs 2586 and 2587. Then remove flush seal plug 2590 and plug the 1/2" NPT opening. Replace the relief valve plug and springs. In this case a separate external bypass valve must be used in the piping between the pump discharge and the storage tank. Set the internal valve at a pressure slightly above the setting on the external valve. Use only the outer relief valve spring 2587 for units with 1/3 hp motors. Use both springs for 1/2 hp motors and larger. Always replace the flush seal plug 2590 that screws into the relief valve plug 2585 after any relief valve adjustment.

^d Bearing replacement: Install roller bearing 2471 with open side of grease seals toward outside of pump as shown below.

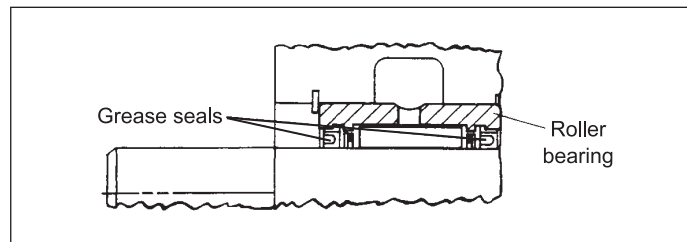

Appendix E—Parts Details for Model F51 (Frame Mount)



CAUTION: Always relieve pressure in the unit before attempting any repairs.

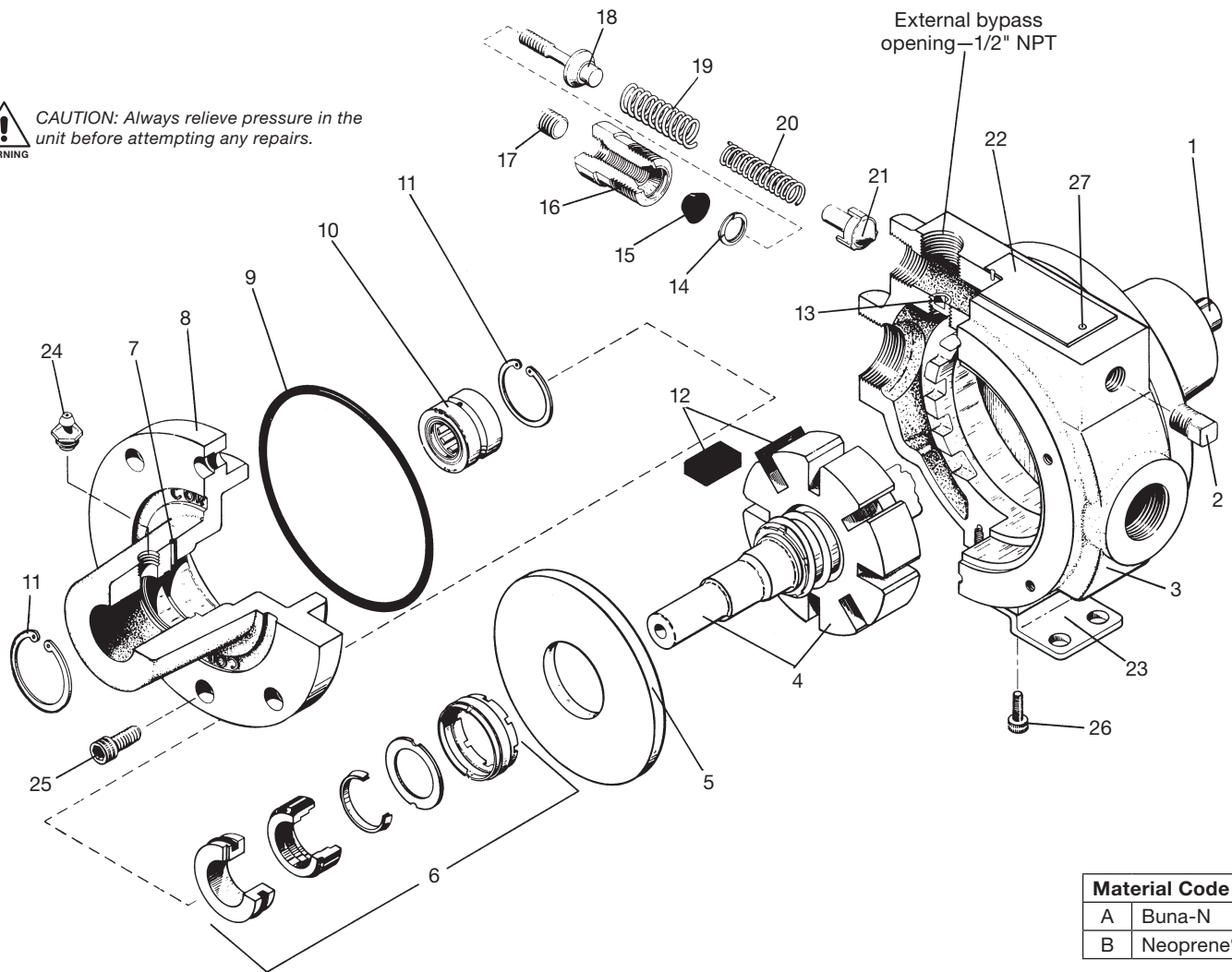

Material Code	
A	Buna-N
B	Neoprene ^{®b}

Ref No.	Part No.	Description	Qty.
1.	2592	Key—1/8" sq. x 9/16"	1
2.	3442	Pipe plug—1/4" NPT	1
3.	2468-1	Case	1
4.	2492-X	Rotor and shaft assembly	1
5.	2491	Sideplate	2
6.	2296-1X_6 ^a	Seal assembly	2
7.	2595	Seat location pin	2
8.	2472	Head	2
9.	2-154_ ^a	Case O-ring	2
10.	2471 ^d	Roller bearing	2
11.	5000-112	Retainer ring	4
12.	2451-2	Carbon vane	8
13.	2590 ^c	Flush plug—1/8" NPT	1
14.	2760-53	Retainer ring	1
15.	2589	Stem seal	1
16.	2585	Relief valve plug	1
17.	2590	Flush plug—1/8" NPT	1
18.	2584-X	Adjusting stem assembly	1
19.	2587 ^c	Outer relief valve spring	1
20.	2586 ^c	Inner relief valve spring	1
21.	2588	Relief valve	1
22.	2591	Nameplate	1
23.	2594	Base	1
24.	2158	Grease zerk—1/8" NPT	2
	2159	Lubricap #2 (not shown)	2

Ref No.	Part No.	Description	Qty.
25.	7002-025NC062A	Bolt socket head	12
26.	7002-010NC050A	Bolt socket head	3
27.	7012-006SF019E	Nameplate screw	2

^a _ denotes material code. See material chart for details.

^b Registered trademark of the DuPont company.

^c The pump relief valve is installed at the factory to operate as an external bypass through the 1/2" NPT hole back to the storage tank. To change from this external configuration to an internal relief valve plug, remove relief valve plug 2585 and relief valve springs 2586 and 2587. Then remove flush seal plug 2590 and plug the 1/2" NPT opening. Replace the relief valve plug and springs. In this case a separate external bypass valve must be used in the piping between the pump discharge and the storage tank. Set the internal valve at a pressure slightly above the setting on the external valve. Use only the outer relief valve spring 2587 for units with 1/3 hp motors. Use both springs for 1/2 hp motors and larger. Always replace the flush seal plug 2590 that screws into the relief valve plug 2585 after any relief valve adjustment.

^d Bearing replacement: Install roller bearing 2471 with open side of grease seals toward outside of pump as shown below.

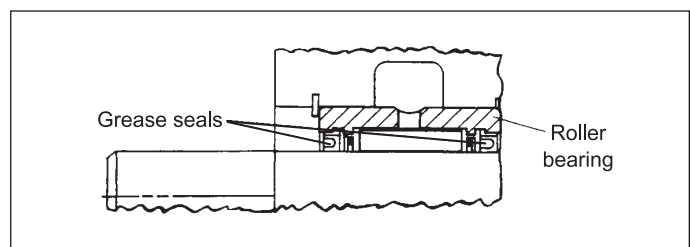

Appendix E—Parts Details for Seal Assembly (1769 Series)

All Models 521 and 1021



CAUTION: Always relieve pressure in the unit before attempting any repairs.

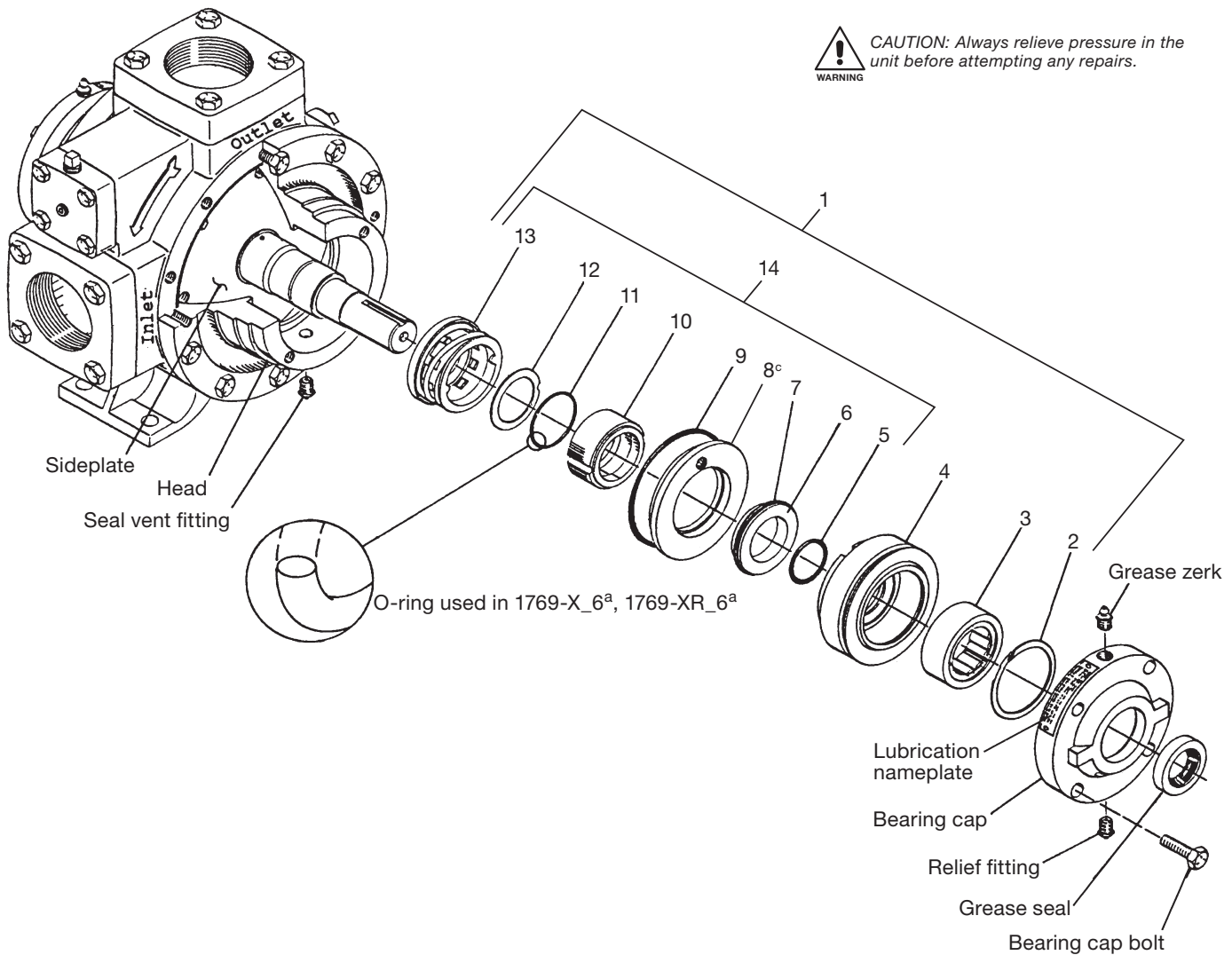

Ref No.	Part No.	Description	Qty.
1.	1769-X_6 ^a	Complete seal assembly	1
2.	2760-244	Retainer ring	1
3.	2754-X	Roller bearing, complete	1
	2754	Bearing outer race	1
4.	2755	Bearing inner race	1
	1769	Bearing housing	1
5.	2-128_ ^a	Shaft O-ring	1
6.	Not sold separately ^d	Seal seat	1
7.	2-227_ ^a	Seat O-ring	1
8.	1822 ^c	Seat adapter plate	1
9.	2-240_ ^a	Adapter plate O-ring	1
10.	Not sold separately ^d	Carbon seal	1
11.	2-223_ ^a	Rotor O-ring	1
12.	Not sold separately ^d	Disc	1
13.	Not sold separately ^d	Retainer assembly	1
14.	1769-XR_6 ^a	Field replacement seal assembly	1

Material Code	
A	Buna-N
B	Neoprene ^{®b}

^a _ denotes material code. See material code chart for details.

^b Registered trademark of the DuPont company.

^c Not included in field replacement seal assembly.

^d Not sold separately. Available with 1769-X_6^a and 1769-XR_6^a only.

Appendix E—Parts Details for Models 521 and 1021

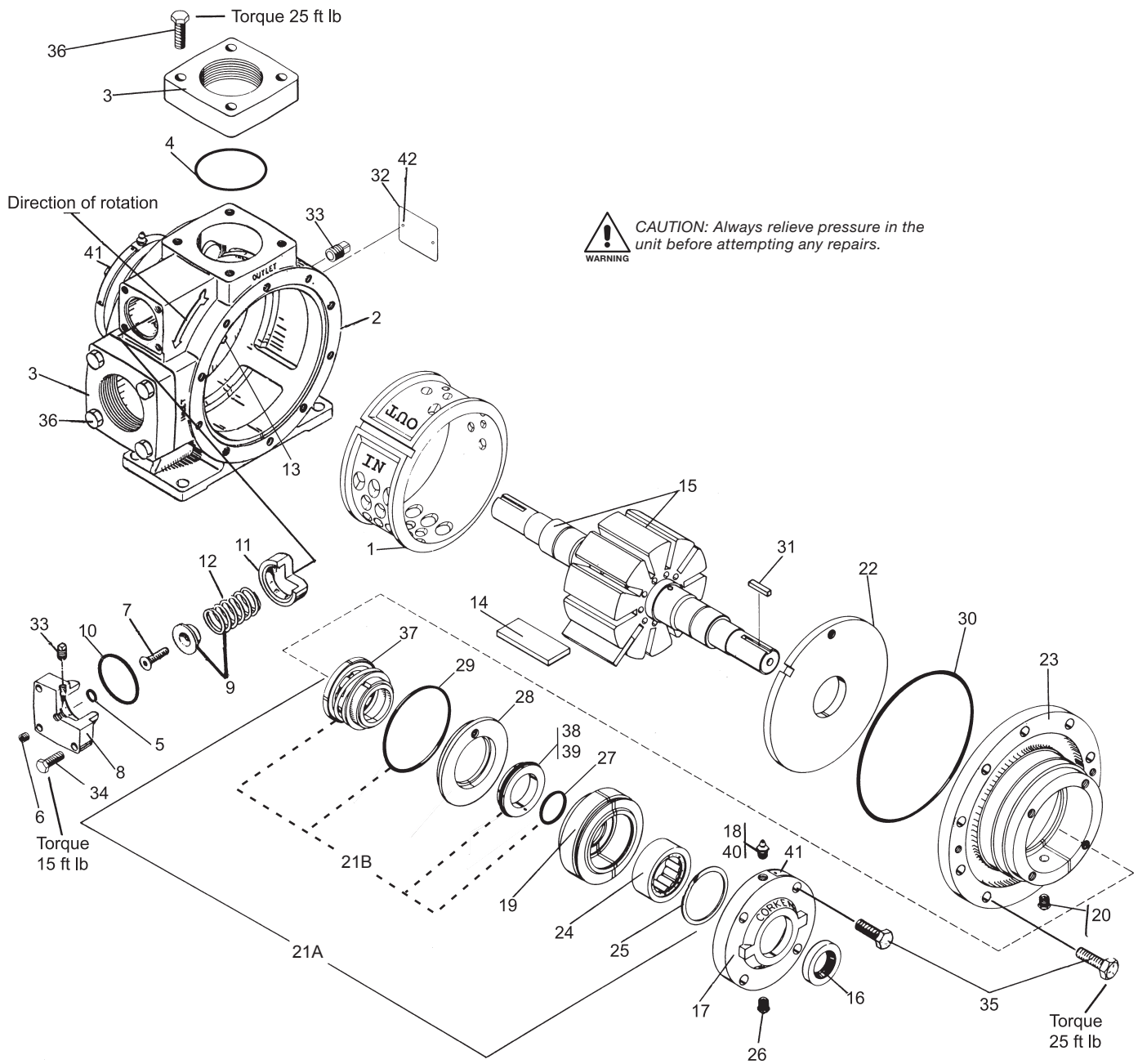

Sideplate Replacement Instructions

Model 521

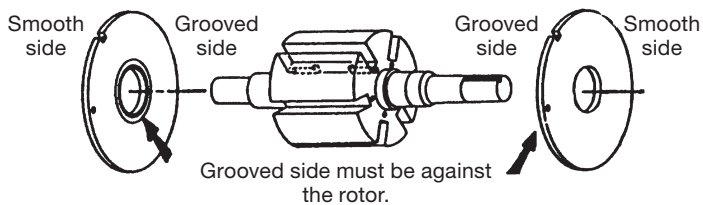

Model 1021

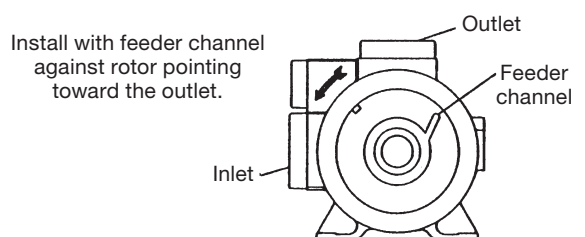

Appendix E—Parts Details for Models 521 and 1021

Ref No.	Part No.	Description	Qty.
1.	1162-2	Cam (521)	1
	1201-2	Cam (1021)	1
2.	2832	Case (521)	1
	2841	Case (1021)	1
3.	1172-2.5	Flange—2-1/2" standard (521)	1
	1172-2	Flange—2" standard (521)	1
	1172-1.5	Flange—1/2" NPT, optional (521)	1
	1172-15S	Flange—1/2" Weld, optional (521)	1
	1172-2	Flange—2" NPT, optional (521)	1
	1172-2S	Flange—2" Weld, optional (521)	1
	1172-2.5	Flange—2-1/2" NPT, optional (521)	1
	1172-2.5S	Flange—2-1/2" Weld, optional (521)	1
	1206-34	Flange—3" standard (1021)	2
	1206-3S	Flange—3" Weld, optional (1021)	2
	1206-4	Flange—4" NPT, optional (1021)	2
	1206-4S	Flange—4" Weld, optional (1021)	2
	4.	2-234 _a	Flange O-ring (521)
2-245 _a		Flange O-ring-3" (1021)	2
2-249 _a		Flange O-ring-4" (1021)	2
5.	2-112 _a	Adjusting screw O-ring	1
6.	2590	Flush plug—1/8" NPT	1
7.	2252	Relief valve adjusting screw	1
8.	1174	Valve cap (521)	1
	1207	Valve cap (1021)	1
9.	1242-X	Relief valve spring and guide (521)	1
	1227	Relief valve spring guide (1021)	1
10.	2-224 _a	Relief valve cap O-ring (521)	1
	2-228 _a	Relief valve cap O-ring (1021)	1
11.	1241	Relief valve (521)	1
	1224	Relief valve (1021)	1
12.	1242	Relief valve spring (521)	1
	1226	Relief valve spring (1021)	1
13.	1170	Cam key (521)	1
	1309	Cam key (1021)	1
14.	1168-7	Blade (521)	10
	1308-9	Blade (1021)	10
15.	1166-1X1R	Rotor and shaft assembly (521)	1
	1208-1X1R	Rotor and shaft assembly (1021)	1
16.	1358	Grease seal	2
17.	1164-1	Bearing cap	2
18.	2158	Grease zerk—1/8" NPT	2
19.	1769	Bearing housing	2
20.	1343	Seal vent relief fitting—1/8" NPT	2

Ref No.	Part No.	Description	Qty.
21A.	1769-X ₆ ^a	Complete seal assembly kit. Includes bearing housing, seat adapter plate, bearings, retainer rings, seal, and O-rings.	2
21B.	1769-XR ₆ ^a	Seal assembly field replacement kit. Includes only the seal and O-rings.	2
22.	1163-2 ^d	Sideplate (521)	2
	1209-1 ^d	Sideplate (1021)	2
23.	1161-4	Head (521)	2
	1205-4	Head (1021)	2
24.	2754-X	Roller bearing—complete	2
	2755	Bearing inner race	2
	2754	Bearing outer race	2
25.	2760-244	Retainer ring	2
26.	1343	Grease relief fitting—1/8" NPT	2
27.	2-128A	Shaft O-ring (Buna-N only)	2
28.	1882	Seat adapter plate	2
29.	2-240 _a	Adapter plate O-ring	2
30.	2-261 _a	Case O-ring (521)	2
	2-268 _a	Case O-ring (1021)	2
31.	2270	Key—1/4"	2
32.	2949	Nameplate	1
33.	3442	Plug—1/4" NPT	1
34.	7001-031NC125A	Hex head bolt—5/16-18x1-1/4 (521)	4
	7001-037NC125A	Hex head bolt—3/8-16x1-1/4 (1021)	4
35.	7001-037NC125A	Hex head bolt—3/8-16x1-1/4 (521)	28
	7001-037NC125A	Hex head bolt—3/8-16x1-1/4 (1021)	32
36.	7001-037NC150A	Hex head bolt—3/8-16x1-1/2	8
37.	Not sold separately ^b	Retainer	2
38.	Not sold separately ^b	Seal seat	2
39.	2-227 _a	Seal seat O-ring	2
40.	2159	Lubricap #2	2
41.	1359	Lubrication instruction tag	2
42.	7003-004DR0198	Round head plated drive screw—4 x 3/16	2

Material Code	
A	Buna-N
B	Neoprene ^{®c}
D	Viton ^{®c}
E	PTFE

^a _ denotes material code. See material code chart for details.

^b Not sold separately. Available with 1769-X₆^a, and 1769-XR₆^a only.

^c Registered trademark of the DuPont company.

^d See sideplate replacement instructions.

Appendix E—Parts Details for Model F1021

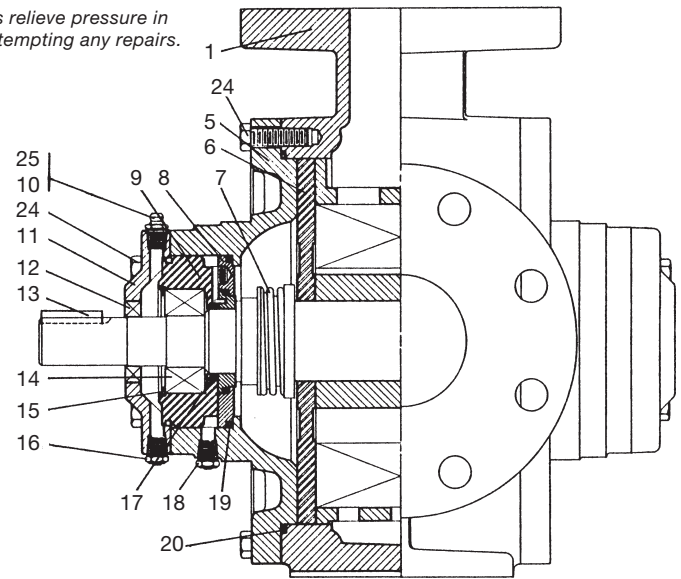
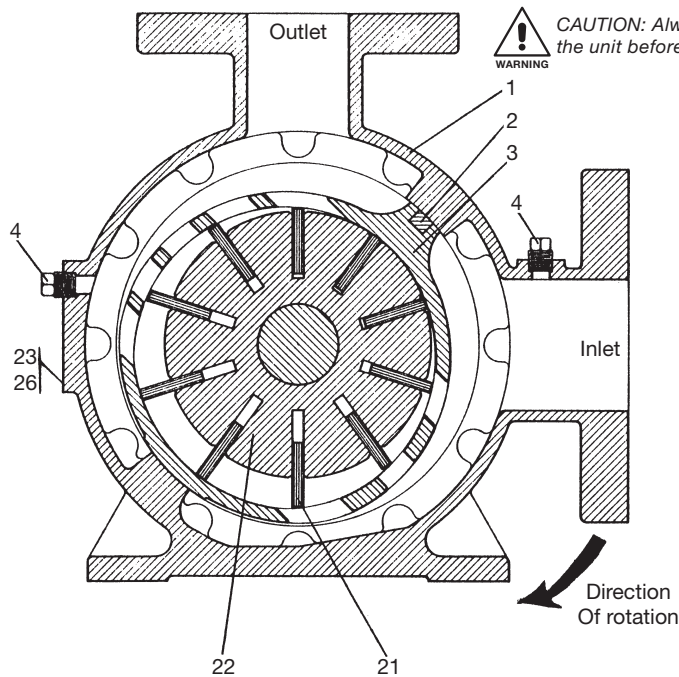

Ref No.	Part No.	Description	Qty.
1.	2433	Case	1
2.	1309	Cam key	1
3.	1201-2	Cam	1
4.	3442	Plug—1/8" NPT	2
5.	1205-4	Head	2
6.	1209-1 ^d	Sideplate	2
7.	1769-X ₆ ^a	Complete seal assembly kit. Includes bearing housing, seat adapter plate, bearings, retainer rings, seal, and O-rings.	2
	1769-XR ₆ ^a	Seal assembly field replacement kit. Includes only the seal and O-rings.	2
8.	1822	Seat adapter plate	2
9.	1769	Bearing house	1
10.	2158	Grease zerk—1/8" NPT	1
11.	1164-1	Bearing cap	2
12.	1358	Grease seal	1
13.	2270	Key—1/4"	1
14.	2754-X	Roller bearing—complete	2
	2755	Bearing inner race	2
	2754	Bearing outer race	2
15.	2760-244	Retainer ring	1
16.	1343	Grease relief fitting—1/8" NPT	2
17.	2-128A	Shaft O-ring (Buna-N only)	1
18.	1343	Seal vent relief fitting—1/8" NPT	1
19.	2-240 ^a	Adapter plate O-ring	1
20.	2-268 ^a	Case O-ring	2

Ref No.	Part No.	Description	Qty.
21.	1308-9	Vane	10
22.	1208-1X1R	Rotor and shaft assembly with 2755	1
23.	2649	Nameplate	1
24.	7001-037NC125A	Hex head bolt—3/8-16x1-1/4"	32
25.	2159	Lubricap #2	2
26.	7012-006SF019E	Round head drive screw—6-32x3/16	6

Material Code

A	Buna-N
B	Neoprene ^{®b}

^a _ denotes material code. See material code chart for details.

^b Registered trademark of the DuPont company.

^c See sideplate replacement instructions.

Sideplate Replacement Instructions

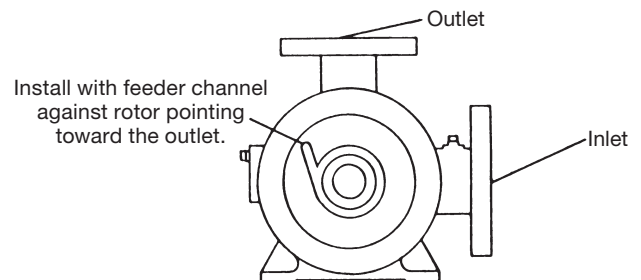

Appendix E—Parts Details for Rotor, Blade, Sideplate, and Cam

New Part Interface Dimensions

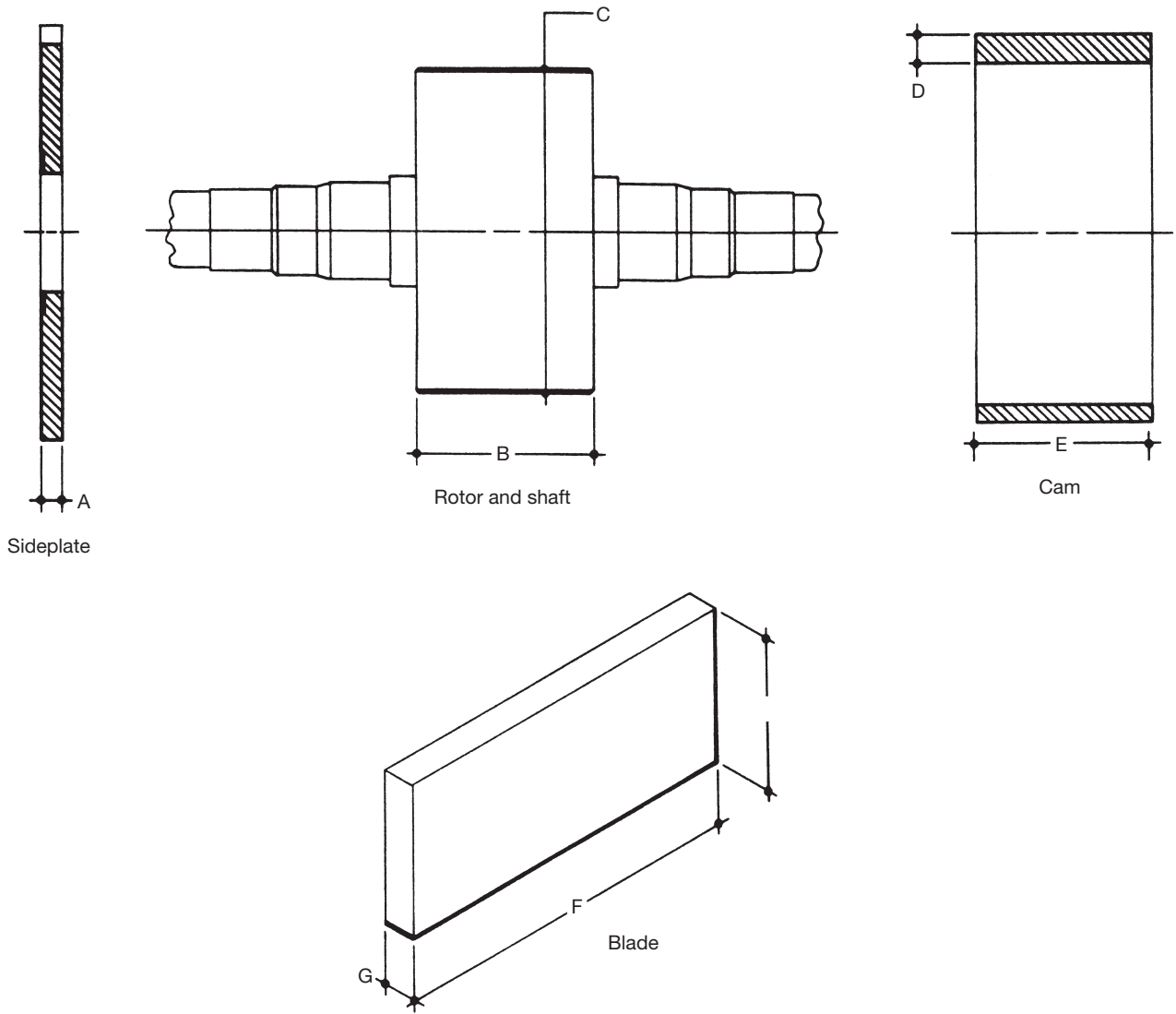

Model	A (min)	B (max)	C (max)	D (max)	E (min)	F (max)	G (max)	H (nominal)
500	0.373	2.992	5.449	0.750	3.000	2.994	0.230	1.323
1000	0.435	3.993	6.249	1.123	4.002	3.997	0.230	1.500
1500	0.435	6.243	6.125	1.184	6.253	6.229	0.549	1.635

Appendix F—V-Belt Selection for Sliding-Vane Pumps

1,450 RPM Motor			Motor Hp	Nominal Pump RPM	1,750 RPM Motor		
Belt Number	Sheave Pitch Diameter				Sheave Pitch Diameter		Belt Number
	Pump	Motor			Pump	Motor	
B64	B15.4	B7.4	2	420	1-3V14.0	1-3V3.35	3V600
B60	B13.6	B4.2		470	1-3V10.6	1-3V2.80	3V530
B60	B12.4	B4.2		520	1-3V10.6	1-3V3.15	3V530
B55	B11.0	B4.2		580	1-3V10.6	1-3V3.65	3V560
B56	B11.0	B4.8		640	1-3V8.0	1-3V3.00	3V500
B64	B15.4	B4.4	3	420	2-3V10.6	2-3V2.65	3V530
B64	B15.4	B4.8		470	2-3V10.6	2-3V2.80	3V530
A55	2A10.6	2A3.6		520	1-3V14.0	1-3V4.12	3V630
B55	2B11.0	2B4.2		580	1-3V14.0	1-3V4.75	3V630
B60	B12.4	B5.4		640	2-3V8.0	2-3V3.00	3V500
B56	B11.0	B5.2		710	2-3V6.9	2-3V2.80	3V475
B53	B9.4	B4.8		780	1-3V8.0	1-3V3.65	3V500
B53	B8.6	B5.0		860	2-3V5.3	2-3V2.65	3V450
B51	B7.4	B4.8		950	1-3V6.5	1-3V3.65	3V475
B64	2B15.4	2B4.4	5	420	3-A13.2	3-A3.2	A60
B60	2B13.6	2B4.2		470	2-A13.2	2-A3.6	A60
B60	2B12.4	2B4.2		520	2-A12.0	2-A3.6	A56
B55	2B11.0	2B4.2		580	2-3V10.6	2-3V3.65	3V560
B56	2B11.0	2B4.8		640	3-3V8.0	3-3V3.00	3V500
B56	2B11.0	2B5.2		710	2-3V8.0	2-3V3.35	3V500
B53	2B9.4	2B4.8		780	2-3V6.9	2-3V3.15	3V475
B53	2B8.6	2B5.0		860	2-3V6.5	2-3V3.15	3V475
B51	2B7.4	2B4.8		950	2-3V6.0	2-3V3.35	3V475
B64	3B15.4	3B4.4	7-1/2	420	4-A13.2	4-A3.2	A60
B64	2B15.4	2B4.8		470	3-A13.2	3-A3.6	A60
B60	3B12.7	3B4.2		520	3-3V14.0	3-3V4.12	3V630
B55	3B11.0	3B4.2		580	2-3V14.0	2-3V4.75	3V630
B56	3B11.0	3B4.8		640	2-3V14.0	2-3V5.30	3V630
B56	3B11.0	3B5.2		710	2-3V10.6	2-3V4.50	3V560
B53	3B9.4	3B4.8		780	3-3V6.9	3-3V3.15	3V475
B53	3B8.6	3B5.0		860	3-3V6.5	3-3V3.15	3V475
B51	3B7.4	3B4.8		950	2-3V8.0	2-3V4.50	3V530
B71	3B18.4	3B5.2	10	420	3-3V19.0	3-3V4.50	3V710
B71	2B18.4	2B5.8		470	3-3V19.0	3-3V5.00	3V710
B60	4B12.4	4B4.2		520	3-3V14.0	3-3V4.12	3V630
B55	4B11.0	4B4.2		580	3-3V14.0	3-3V4.50	3V630
B56	4B11.0	4B4.8		640	2-3V14.0	2-3V5.30	3V630
B62	3B12.4	3B5.8		710	2-3V14.0	2-3V5.60	3V630
B56	3B11.0	3B5.8		780	2-B12.4	2-B5.6	B60
B62	3B12.4	3B7.0		860	2-3V10.6	2-3V5.30	3V560
B60	3B9.4	3B6.0		950	2-3V10.6	2-3V5.60	3V560
B71	4B18.4	4B5.2	15	420	4-3V19.0	4-3V4.75	3V710
B71	3B18.4	3B5.8		470	4-3V19.0	4-3V5.00	3V710
B62	5B13.6	5B4.8		520	3-3V19.0	3-3V5.60	3V750
B60	5B12.4	5B4.8		580	4-3V14.0	4-3V4.75	3V630
B56	5B11.0	5B4.8		640	3-3V14.0	3-3V5.30	3V630
B56	5B11.0	5B5.2		710	3-3V14.0	3-3V5.60	3V630
B53	5B9.4	5B4.8		780	3-B12.4	3-B5.6	B60
B53	5B8.6	5B5.0		860	2-B12.4	2-B6.0	B60
B51	5B7.4	5B4.8		950	2-B11.0	2-B6.0	B56
B75	4B18.4	4B6.6	20	520	4-3V19.0	4-3V5.60	3V750
B68	4B15.4	4B6.8		640	4-3V14.0	4-3V5.30	3V630
B64	4B12.4	4B6.6		780	3-B13.6	3-B6.0	B62
B68	3B13.6	3B8.0		860	4-3V10.6	4-3V5.30	3V560
B65	3B12.4	3B8.0		950	3-B11.0	3-B6.0	B56

Do not use a V-belt drive system on a Coro-Vane® pump with a driver greater than 25 horsepower. Consult factory if your application is outside this parameter.

Appendix G—Troubleshooting Guide

In diagnosing pump and system troubles, record the following data during product transfers:

1. Pressure at pump suction.
2. Pressure at pump discharge.
3. Pressure in truck tank.
4. Pressure in tank being filled.
5. Pipe size and length of suction and discharge lines.
6. Size and length of vapor equalizing line.
7. Pump speed if practical.

Symptom	Probable Cause	Remedy
Low capacity	Pump speed too slow	Check engine speed and PTO ratio. Consult pump performance curve. Use tachometer on pump if speed is questionable.
	High differential pressure	Restriction in discharge piping or hose too small. Vapor equalization lines too small or not used.
	External bypass valve stuck open or set too low	Readjust, repair, or replace valve.
	Clogged strainer	Clean strainer.
	Suction pipe too small or restricted	Indicated by pump inlet pressure dropping several pounds when pump is started. Remove restriction or modify piping.
	Worn vanes	Replace.
	Pump without vapor return	Without vapor equalization, a pump can remove only about 3% of the truck tank capacity per minute without severe cavitation and capacity loss.
	Worn sideplates	Reverse or replace sideplates. Check universal drive assembly to make sure angularity is within limits, yokes are parallel and slip-joint is greased. Check bearings.
Pump runs but no flow	Vanes sticking	Remove vanes and clean out foreign matter (check strainer). Replace vanes if swollen.
	Valve closed	Check valves. Make sure internal tank excess flow valve is open! Refer to manufacturer's instructions.
	Excess flow valve slugged	Stop pump until valve opens. If problem continues, slow pump down or install a new or larger excess flow valve.
	Broken shaft	Disassemble and inspect pump. Repair if necessary.
Pump will not turn or is locked up	Defective meter	Service meter.
	Foreign matter in pump	Clean out the pump and check strainer in suction line
	Vanes broken	Clean out pump carefully and replace vanes. Has pump been operated dry? Then, check for damage to cam and rotor shaft assembly.
	Bearing seized	Replace pump bearings. Grease monthly. Use ball bearing grease manufactured for intended service.
Will not build pressure	Moisture frozen in pump	Let thaw and break loose carefully. Add alcohol to tank (on LP-Gas). Check with product supplier about the possibility of water in the gas.
	Poor suction conditions	Clean inlet strainer. Increase pipe size.
	External bypass valve set too low	Set valve for higher pressure—see instructions.
Pump is noisy	Worn vanes and/or sideplates	Disassemble, inspect and repair as necessary. Do not run pump dry!
	Cavitation from poor suction conditions	As above.
	Vanes sticking	As above.
	Bearings worn	Replace if necessary and grease monthly.
	Very high differential	Check for restriction in discharge line. Delivery hose too small pressure and too long. Slow down pump! Check vapor release float assembly on meter and meter differential valve.
Pump leaks around shaft	PTO shaft vibration	Inspect and repair driveline component.
	Seal or O-rings failed	Inspect seal assembly and replace if necessary. Keep new seal very clean when replacing seal. Recommend a light oil film on O-rings. Do not run pump dry!

Appendix H—Extended Storage Procedures

If the pump is to be removed from service for some time, it must be protected as propane, butane, and anhydrous ammonia all leave the metal “bare” and open to corrosion. Piping and tanks not in service should also be protected, as the rust particles can destroy the pump’s seals almost immediately after startup.

1. Fill or thoroughly flush the pump with a light rust inhibiting oil. (If the pump is flushed with oil, place some desiccant packets inside the pump for added protection.)
2. Plug all pump openings.
3. Store in a dry location.
4. Before placing the pump back into service, drain the oil and remove any desiccant packets.
5. Refer to the “Operation Procedures” on page 7 of this Installation, Operation and Maintenance (IOM) manual.

Solutions beyond products...

CORKEN®

CORKEN, INC. • A Unit of IDEX Corporation

9201 North I-35 Service Road, Oklahoma City, OK. 73131

Phone (405) 946-5576 • Fax (405) 948-7343

Visit our website at <http://www.corken.com>

or e-mail us at cocsalesdept@idexcorp.com



Installation, Operation & Maintenance Manual

Z-Series Sliding Vane Pumps Truck and Stationary

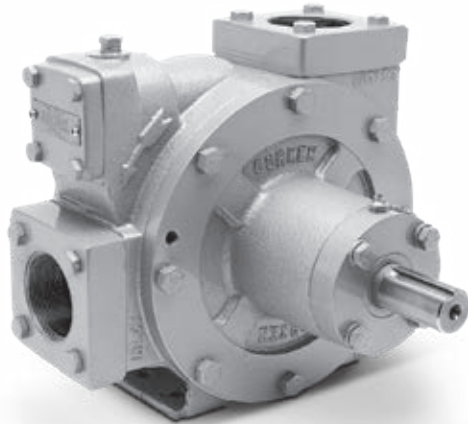

Model Z2000 Truck Pump

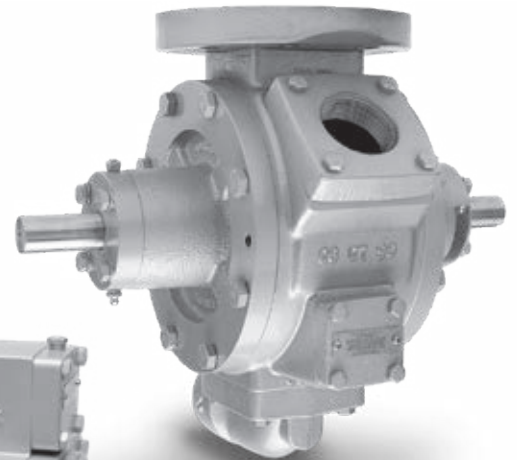

Model Z3200 Truck Pump

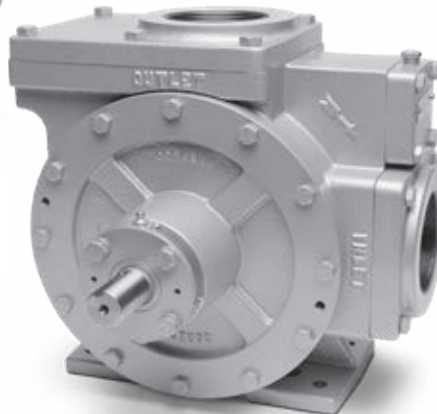

*Model Z3500 Truck and
Stationary Pump*

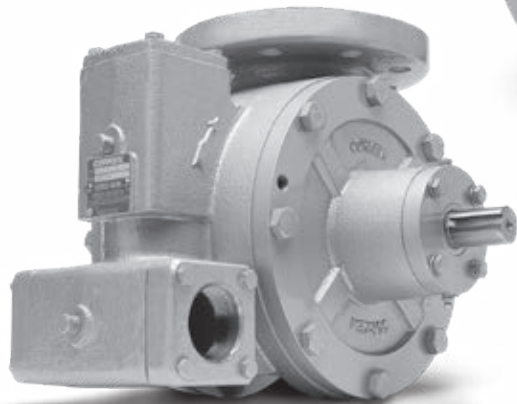

Model Z4200 Truck Pump



Model Z4500 Stationary Pump

Warning: (1) Periodic inspection and maintenance of Corken products is essential. (2) Inspection, maintenance and installation of Corken products must be made only by experienced, trained and qualified personnel. (3) Maintenance, use and installation of Corken products must comply with Corken instructions, applicable laws and safety standards (such as NFPA Pamphlet 58 for LP-Gas and ANSI K61.1-1972 for Anhydrous Ammonia). (4) Transfer of toxic, dangerous, flammable or explosive substances using Corken products is at user's risk and equipment should be operated only by qualified personnel according to applicable laws and safety standards.

Solutions beyond products...

CORKEN[®]
IDEX

Warning

Install, use and maintain this equipment according to Corken's instructions and all applicable federal, state, local laws and codes. Periodic inspection and maintenance is essential.

Corken One Year Warranty

CORKEN, INC. warrants that its products will be free from defects in material and workmanship for a period of one year from date of installation, provided that the warranty shall not extend beyond twenty-four (24) months from the date of shipment from CORKEN. If a warranty dispute occurs, the DISTRIBUTOR may be required to provide CORKEN with proof of date of sale. The minimum requirement would be a copy of the DISTRIBUTOR'S invoice to the customer.

CORKEN products which fail within the warrant period due to defects in material or workmanship will be repaired or replaced at CORKEN's option, when returned, freight prepaid to CORKEN, INC., 9201 North I-35 Service Road, Oklahoma City, OK. 73131.

Parts subject to wear or abuse, such as mechanical seals, blades, piston rings, valves and packing, and other parts showing signs of abuse, neglect or failure to be properly maintained are not covered by this limited warranty. Also, equipment, parts and accessories not manufactured by CORKEN but furnished with CORKEN products are not covered by this limited warranty and the purchaser must look to the original manufacturer's warranty, if any. This limited warranty is void if the CORKEN product has been altered or repaired without the consent of CORKEN.

All implied warranties, including any implied warranty of merchantability or fitness for a particular purpose, are expressly negated to the extent permitted by law and shall in no event extend beyond the expressed warrantee period.

CORKEN DISCLAIMS ANY LIABILITY FOR CONSEQUENTIAL DAMAGES DUE TO BREACH OF ANY WRITTEN OR IMPLIED WARRANTY ON CORKEN PRODUCTS. Transfer of toxic, dangerous, flammable or explosive substances using CORKEN products is at the user's risk. Experienced, trained personnel in compliance with governmental and industrial safety standards should handle such substances.

Important notes relating to the European Union (EU) Machinery Directive

Pumps delivered without electric motors are not considered as machines in the EU Machinery Directive. These pumps will be delivered with a Declaration of Incorporation. The fabricator of the machinery must assure and declare full compliance with this Directive before the machine in which the pump will be incorporated, or of which it is a part, is put into service.

Contacting the Factory

Before you contact the factory, note the model number and serial number of your pump. The serial number directs us to a file containing all information on material specifications and test data applying to your specific pump. When ordering parts, the Corken service manual or Operations, Installation and Maintenance (IOM) manual should be consulted for the proper part numbers. ALWAYS INCLUDE THE MODEL NUMBER AND SERIAL NUMBER WHEN ORDERING PARTS.

The model and serial numbers are shown on the nameplate of the unit. Record this information for future reference.

Model No. _____

Serial No. _____

Date Purchased _____

Date Installed _____

Purchased From _____

Installed By _____

Table of Contents

APPLICABLE NOTICES FOR ATEX 94/9/EC CONFORMITY	4
PRINCIPLES OF THE Z-SERIES SLIDING VANE PUMP (CORO-VANE®)	5
EXCLUSIVE FEATURES OF THE Z-SERIES CORO-VANE® PUMP	5
CHAPTER 1—INSTALLATION OF THE Z-SERIES CORO-VANE® TRUCK PUMP	5
1.1 The Outlet Piping Should Include the Following	6
1.2 The Bypass System	6
1.3 Power Take-off (PTO) Drive Systems	6
1.4 Hydraulic Drive Systems	7
CHAPTER 2—OPERATION OF THE Z-SERIES CORO-VANE® TRUCK PUMP	7
2.1 How to Transfer From the Truck Tank at Full Capacity	7
CHAPTER 3—INSTALLATION OF THE Z-SERIES CORO-VANE® STATIONARY PUMP	8
3.1 The Inlet Piping Should Include the Following	8
3.2 The Outlet Piping Should Include the Following	8
3.3 The Bypass System Must Include the Following	9
3.4 A Vapor Equalizing System Should be Included	9
3.5 Driver Installation	9
CHAPTER 4—OPERATION OF THE Z-SERIES STATIONARY CORO-VANE® PUMP	10
CHAPTER 5—MAINTENANCE OF THE Z-SERIES CORO-VANE® PUMP	11
5.1 Purpose	11
5.2 Scope	11
5.3 Procedures	11
CHAPTER 6—Z-SERIES CORO-VANE® SEAL REPLACEMENT INSTRUCTIONS	13
6.1 Repair/Rebuild Kits with Iron Seal Seat	16
6.2 Repair/Rebuild Kits with Silicon Carbide Seal Seat	17
6.3 Assembly Instructions For All Z-Series Repair and Rebuild Kits	18
APPENDICES	
A. Model Number Identification Code and Available Options	19
B. Specifications	21
C. Performance	22
D. Outline Dimensions	28
E. Parts Details	38
F. V-Belt Selection	45
G. Troubleshooting Guide	46
H. Extended Storage	48
I. Hydraulic Motor Specifications	48

Applicable Notices for ATEX 94/9/EC Conformity

Product Type:

Sliding Vane Pump (Coro-Vane®)

Models Covered:

Z/ZH2000, ZX/ZXH2000, Z/ZH3200, Z3500, Z/ZH4200, and Z4500

Intended Application:

The pump models covered by this manual conform to the European Union ATEX 94/9/EC Directive for explosive gas atmospheres and transfer of liquefied gases such as Liquefied Petroleum Gas, anhydrous ammonia, freons, etc. Electric motors for these pumps in the assembly must comply with all applicable requirements for local, federal, and regional codes and regulations.

Possible Misuse Warning:

The designated pump models must only be installed in systems designed for its intended use, similar to the examples presented in this manual.

ATEX Classification:

Group II; Category 2; G; Temperature Class T4 – T5

These products are classified under the ATEX directive as Equipment – Group II – Category 2 – equipment is intended for use in areas where explosive atmospheres caused by gases or vapors (G) may be present. The surface Temperature Class rating is a range between T4 275°F (135°C) and T5 212°F (100°C).

Nameplate:

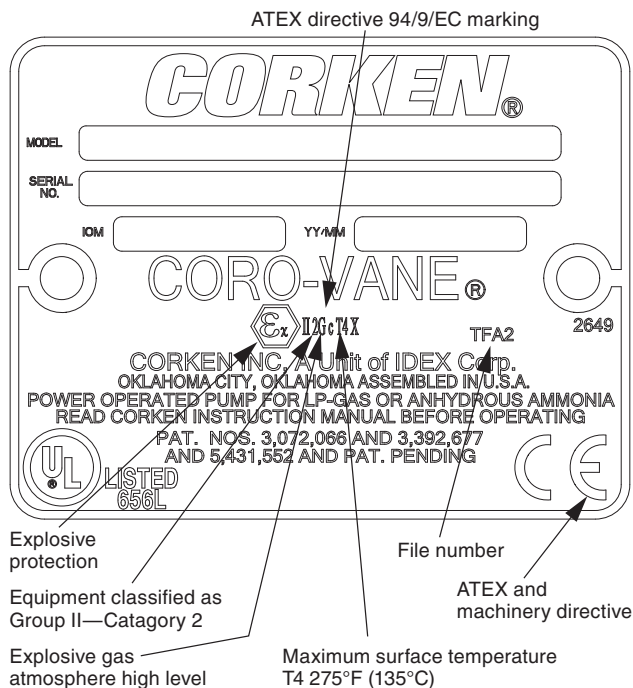

Training Instructions:

Instructions for the safe application and use of this product are provided in this manual. Read this manual completely prior to installation and use of this product. Only qualified and properly trained personnel should be allowed to install, operate, and maintain this equipment.

Mechanical Ignition Sources:

This equipment may be direct driven through a coupling by an electric motor or belt driven by an electric motor. Guards for the drive mechanism in the assembly intended for personal protection are to be supplied by the customer. The pump assembly including the drive system must be grounded to prevent possible electrostatic discharge. Internal parts of the pump require fluid (product being pumped) or damage may occur. Do not run the pump dry (without liquid in the pump). The application of liquid level controls in the pump system is recommended. Preventive Maintenance guidelines are provided in this manual and are to be followed for the proper operation and performance of the pump.

Sound Levels:

When properly installed and operated, these pumps do not exceed 85 dBA noise levels at a distance of one meter (3.281 ft) from the surface of the pump. This value is highly dependent upon the installation and may vary from installation to installation.

Piping Forces and Moments:

Maximum Allowable Pipe Torque

Z/ZH/ZX/ZXH2000

Inlet	Size	2 in. (50 mm)
	Torque	1,650 in•lbs (186 N•m)
Outlet	Size	2 in. (50 mm)
	Torque	1,650 in•lbs (186 N•m)

Z/ZH3200 and Z3500

Inlet	Size	3 in. (80 mm)
	Torque	1,800 in•lbs (203 N•m)
Outlet	Size	2 in. (50 mm)
	Torque	1,650 in•lbs (186 N•m)
Auxiliary Inlet	Size	2 in. (50 mm)
	Torque	1,650 in•lbs (186 N•m)

Z/ZH4200

Inlet	Size	4 in. (100 mm)
	Torque	1,900 in•lbs (215 N•m)
Outlet	Size	2 in. (50 mm)
	Torque	1,650 in•lbs (186 N•m)
Auxiliary Inlet	Size	2 in. (50 mm)
	Torque	1,650 in•lbs (186 N•m)

Preventative Maintenance

Pump Maintenance Schedule:

	Daily	Monthly	3 Months
Lubricate bearings		X	
Inspect drive couplings			X
Clean inlet strainer		X	
Check for leaks	X		
Inspect hose and fittings	X		

Principles of the Z-Series Sliding Vane Pump (Coro-Vane®)

The Z-Series truck pump is a special type of rotary positive displacement pump, known as a sliding vane pump.

The sliding vane pump has many of the positive displacement advantages of the gear pump, plus the ability to compensate for wear, and operate at a lower noise level.

The sliding vane pump consists of a rotor turning in a cam (liner) machined eccentrically in relation to the rotor; thereby displacing the liquid trapped between the rotor, cam and vanes. The Z-Series pumps are made with vanes produced from advanced polymers which exhibit extremely low coefficients of friction. The vanes are self-adjusting for wear which gives the pump long life.

Exclusive Features of the Z-Series Coro-Vane® Pump

The pumping of volatile liquids is one of the most difficult of all pumping jobs, and pumping from a delivery truck makes it even more difficult, so more attention must be given to the design and manufacture of the pump and to its installation and operation.

In addition to being especially suited for handling volatile liquids, the Z-Series pump has a number of features to help make it more easily operated and maintained.

This model has been registered and listed by the UNDERWRITERS' LABORATORIES, INC. for use in the handling of LP-Gas and Ammonia.

The CASE AND HEADS are made of ductile iron for extra strength and toughness.

The VANES are manufactured of advanced polymers to provide excellent life and quiet operation. After long service, the vanes are simply and inexpensively replaced.

Both the CAM and the SIDEPLATES are easily replaced should the need arise. Sideplates may be reversed for extended service life.

The MECHANICAL SEAL is designed for longer life under greater loads and may be inspected or replaced without disturbing the piping of the pump. No special tools are needed.

BEARINGS are heavy-duty roller type for long bearing life.

PRESSURE GAUGE connections, 1/4 in. pipe thread, are provided.

The RELIEF VALVE is built-in and nonadjustable. The valve is preset at the factory.



NOTE: EVEN WITH THIS INTERNAL SAFETY VALVE, AN EXTERNAL BYPASS VALVE MUST BE INSTALLED.

Chapter 1—Installation of the Z-Series Coro-Vane® Truck Pump

Before installing of your pump, remove all temporary plastic plugs.

The installation of the Z-Series pump is simple. However, in order for the pump to deliver optimum performance, the principles discussed in this book should be followed. The piping details are furnished to illustrate methods proved by hundreds of installations. Your own needs may require slight variations, but every effort should be made to follow the recommendations identified in this manual.

For the transfer of flammable liquids like LPG, the pump must be installed according to the applicable local safety and health regulations. The installer and/or the user must take into account the following:

- Potential risk due to local conditions regarding the installation and operation (e.g. poor ventilation and additional risks due to other elements in the vicinity, etc.).
- Qualification of the personnel.
- Type of liquid being transferred.
- Specific safety measures to be applied (e.g. gas detection, automatic shut-off valves, personal protection equipment, etc.).

See Appendix A for shipping weight and Appendix D for outline dimensions.

A rotation arrow is located on the side of the pump so check the Power Take-off (PTO) to determine its direction of rotation. The Z-Series pump will match either PTO rotation. Connect the drive shaft to the pump shaft that turns the pump in the direction of the arrow.

The PTO selection is important. The pump requires a PTO with an average output speed of 420 to 800 RPM when the truck engine is operating at the proper speed to maintain oil pressure and water circulation.

The DRIVESHAFT connecting the pump to the PTO should be of the “splined” or slip type. This type driveshaft permits the shaft to adjust for PTO movement and twisting of the truck frame. A fixed driveshaft transfers the forces directly into the pump and PTO and will shorten the life of both considerably. The yokes of the driveshaft universal joints must be positioned as shown. Improper positioning will soon wear them out and potentially destroy the bearings in the pump and PTO.

INLET PIPING should be as short as possible with minimum restrictions so that the pressure drop is limited. Inlet piping is not generally required on the Z3200 or Z4200. These pumps are bolted directly to the tank internal valve and must be installed in accordance with the valve manufacturer's instructions.

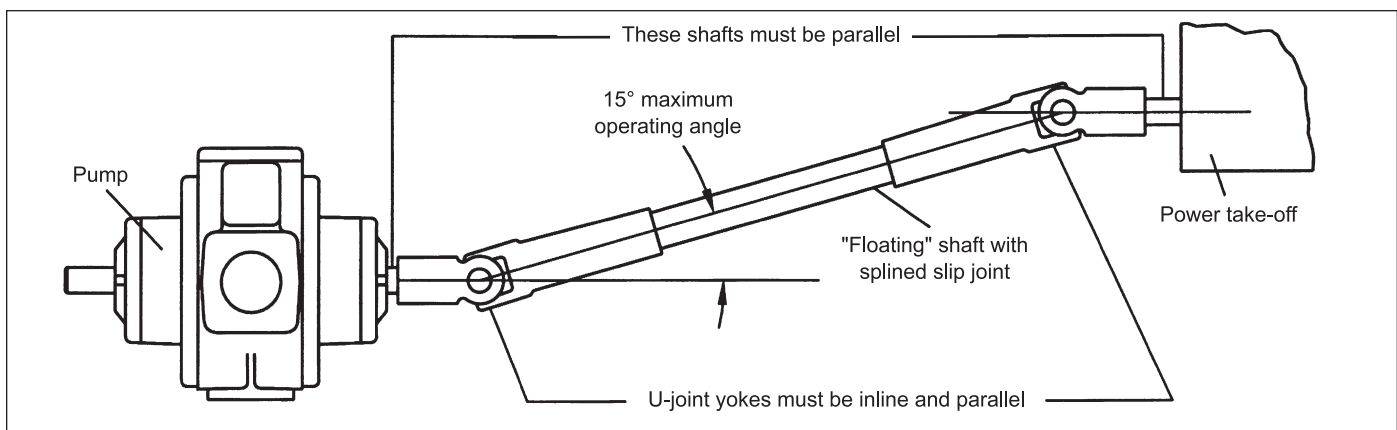

Figure 1.1: Shaft Alignment

1.1 The Outlet Piping Should Include the Following

1. A liquid filled pressure gauge should be installed in the pump outlet or near it. A pressure gauge is necessary to determine the efficiency of your pumping system.
2. A hydrostatic relief valve is required by most state laws and for your own safety.
3. If a meter with a vapor eliminator is installed, pipe the eliminator outlet to the top of your tank. Never pipe the eliminator into the pump inlet piping or into the liquid part of the system at any point.
4. The meter back-pressure valve may be piped into the tank top or into the pump inlet piping.
5. The discharge piping should be at least the same size as the meter.

1.2 The Bypass System

The internal safety relief valve is intended as a safety device and not as an operational bypass valve. The external bypass valve should be set at a differential pressure lower than the internal relief valve and may be connected to the tank at any convenient point, liquid or vapor. All Z-Series pumps (except ZX2000, which is set at 175 psid) are set near 150 psid.

- ZH2000 Foot mounted hydraulic drive with NPT connections
- ZX2000 Foot mounted with NPT connections and high pressure internal relief valve spring (175 psid rather than the standard 150 psid)
- ZHX2000 Foot mounted hydraulic drive with NPT connections and high pressure internal relief valve spring (175 psid rather than the standard 150 psid)

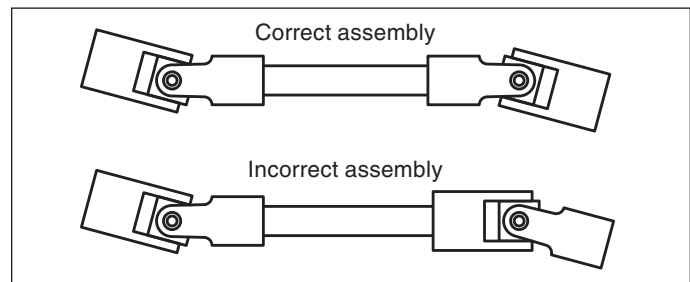

Figure 1.2: Universal Joint Alignment

1.3 Power Take-off (PTO) Drive Systems

Proper pump operation and long life are directly dependent upon a good drive system. Many truck pumps utilize a power train consisting of shafts and universal joints from a power take-off shaft on the truck engine to the pump.

There are several basic principles that should be followed in laying out a PTO drive. These principles should not be violated. Following them will produce a workable power train that results in long pump life and reduced drive wear.

First, the driver shaft and the driven shaft must be parallel to one another within plus or minus one degree. Improper alignment will cause jerking and back and forth "whip" to the pump shaft, thereby imparting a surging pulsation to the liquid flow, which results in noise, vibration, and abnormal wear.

Second, the angle of the "floating" shaft should be within the limits for the particular equipment being used (usually a maximum of 15° at pump speeds up to 800 RPM). To ensure that shaft expansion or contraction does not distort the drive system, a splined slip joint should be placed between the two universal joints. The drive shaft should be of the "splined" or slip type to permit the shaft to adjust for PTO movement and twisting of the truck frame. A fixed drive shaft transmits the forces directly to the pump and PTO which will shorten the life of both considerably.

Third, the yokes of the drive shaft universal joints must be in a parallel position. Figures one and two illustrate the proper arrangement.

Improper installation of the U-joints will soon destroy them along with the bearings in the pump and PTO.

Properly mounted, the second universal gives uniform motion to the drive shaft by compensating for the rotational error introduced by the first U-joint. An even number of universal joints (two, four, six, etc.) should always be used. An odd number of U-joints will cause unbalanced pump shaft rotation. This problem becomes greater with increased angularity.

Other points to consider include the proper sizing of the shaft components with a maximum horsepower load to be expected, good alignment of hanger bearings and proper pump coupling alignment. Improper PTO systems count for a high percentage of truck pump failures. Always remember to disengage the clutch before shifting the PTO into gear. Shifting the PTO into gear without disengaging the clutch imparts an enormous shock on the PTO, drive shaft, pump, and meter and will soon damage one or all of them.

For proper installation of pump drives, follow the rules listed below:

1. Driver shaft and pump shaft must be parallel, plus or minus one degree.
2. Operating angle of the “floating” shaft must be 15 degrees maximum.
3. Universal yokes must be in line and parallel.
4. Splined slip joints must be used where needed.
5. Use an even number of universal joints.
6. Always use the least practical number of shafts.

PTO selection and drive system design is extremely important. The PTO should have an average output speed of 420 to 800 RPM when the truck engine is operating at the recommended speed.

The designer of the drive system must select a PTO drive shaft capable of meeting the torque requirements of the pumping system.

1.4 Hydraulic Drive Systems

Truck pumps are also driven by hydraulic systems, consisting of an adaptor, motor, pump, cooler, and connecting hoses.

The truck pump’s shaft must be properly aligned with the hydraulic motor’s shaft to avoid excessive stress on the truck pump’s main and thrust absorbing bearings. See Appendix D for outline dimensions.

The sizing of the hydraulic motor, hydraulic pump, and hydraulic oil cooler must be done using the operational requirements of the truck pump (e.g. flow rate, differential pressure, pump speed, and required torque and power). These data are on the

performance charts in Appendix C. Information on the Char-Lynn hydraulic motor is found in Appendix I.

Chapter 2—Operation of the Z-Series Coro-Vane® Truck Pump

Performance curves and charts are provided in Appendix C.

The following steps should be performed for the initial pumping operation:

1. Close the shutoff valve on the end of the delivery hose.
2. Follow the instructions of the internal valve manufacturer for putting the valve into operation.
3. Start the pump and circulate liquid through the external bypass system.
4. If your system has a Corken bypass valve, adjust the valve by turning the adjusting screw counter clockwise until the pump discharge pressure gauge shows nearly the same pressure it did before you started the pump. Turn the adjusting screw clockwise until the gauge indicates about 90 to 115 psid above the tank pressure. If a bypass valve of another make is used, follow the instructions provided for adjusting the valve.
5. You may increase the speed of your pump as long as it increases the capacity of the pump and does not exceed the excess flow valve or external bypass valve setting. The one exception occurs when the pump is used to “Pump On” or to load the truck tank. In this case, the pump inlet conditions are poor at best so the pump should be operated at a slower RPM.



NOTE: IF PUMP SPEED IS INCREASED, BE CERTAIN THE METERING SYSTEM WILL HANDLE THE INCREASED FLOW.

WHEN PROPERLY INSTALLED AND OPERATED, Z-SERIES CORO-VANE® TRUCK PUMPS DO NOT EXCEED AN 88 dBA NOISE LEVEL AT A DISTANCE OF ONE METER (3.281 ft) FROM THE SURFACE OF THE PUMP.

2.1 How to Transfer From the Truck Tank at Full Capacity

To move volatile liquids rapidly from a truck tank requires that a condition be maintained within the truck tank that keeps the liquid and the vapors above the liquid in equilibrium. As liquid is removed from the tank, some of the liquid boils to form vapor to fill the space created as the liquid leaves. If this action becomes too violent, the pump will begin to make noise, and the capacity will be reduced. Truck pumps can lower the truck tank pressure from 5 psi to 10 psi (below the starting tank pressure). If there is no means provided for equalizing, then the trouble starts! As the weather gets colder, the worse this condition will become.

You can detect this “pull down” in pressure by observing your truck tank pressure gauge as the pump is operating.

To prevent this violent liquid boiling, pressure in some form must be introduced into the truck tank. The simple way to accomplish this is to “equalize” between the truck tank and the receiving tank. Equalizing takes the higher pressure vapors from the receiving tank and returns them to the truck tank. As a result, the void left by the receding liquid is filled. This in turn lessens the need for the liquid to boil excessively. The equalizing principle is necessary for volatile liquids.

NOTE: EQUALIZING BETWEEN TANKS OR THE ADDITION OF PRESSURE IS NOT A LEGAL TRANSFER IN MOST STATES. IF EQUALIZING LINES ARE NOT PERMITTED REMEMBER THAT A QUIET PUMP IS AN EFFICIENT PUMP. A NOISY PUMP IS NOT EFFICIENT AND THE CONDITIONS THAT CAUSE THE NOISE ALSO CAUSE WEAR TO INTERNAL PARTS. OPERATE THE PUMP AT SPEEDS THAT RESULT IN A “QUIET” TRANSFER.

NOTE: EVEN WITH THIS INTERNAL SAFETY VALVE, AN EXTERNAL BYPASS VALVE MUST BE INSTALLED.

Chapter 3—Installation of the Z-Series Coro-Vane® Stationary Pump

NOTE: All pumps should be installed in a well ventilated area.

The installation of the Coro-Vane® pump is simple. However, in order for the pump to deliver optimum performance, the principles discussed in this book should be followed. The piping details are furnished to illustrate methods proved by hundreds of installations. Your own needs may require slight variations, but every effort should be made to follow the recommendations identified in this manual.

No pump can discharge more liquid than it receives, so the pump location and the inlet piping must be given careful attention. If the inlet piping is inadequate to supply the demand of the pump, you may expect trouble.

For the transfer of flammable liquids like LPG, the pump must be installed according to the applicable local safety and health regulations. The installer and/or the user must take into account the following:

- The pump must be located as near the storage tank as possible. For best results the pump inlet line including the vertical line from the tank should not exceed 12 feet (3.7 m) in length.
- The bottom of the tank should be at least two feet (0.6 m) above the pump center line. For best results four feet (1.2 m) is preferred.
- The foundation for the pump is important. The foundation must be firm, level and preferably made of concrete. The suggestions in figure three should be observed.

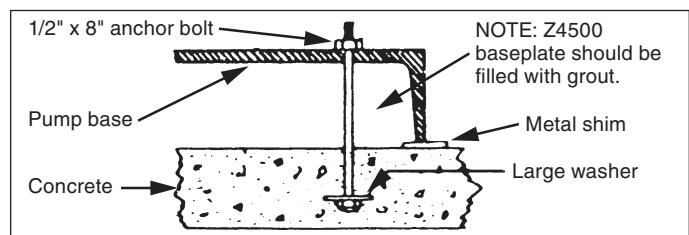

Figure 3.1

- Potential risk due to local conditions regarding the installation and operation (e.g. poor ventilation and additional risks due to other elements in the vicinity, etc.).
- Qualification of the personnel.
- Type of liquid being transferred.
- Specific safety measures to be applied (e.g. gas detection, automatic shut-off valves, personal protective equipment, etc.).

Appendix A shows the weight of the bare pump for each model. For handling a bare pump, lifting slings should be used. Web slings are preferred over metal slings to minimize damage to the paint. See Appendix D for outline dimensions.

3.1 The Inlet Piping Should Include the Following

1. The tank excess flow valve (EFV) should have a flow rate of 1-1/2 to 2 times the capacity of the pump. Do not use an EFV without knowing its flow capacity.
2. The tank shut-off valve should be a free-flow type and not a standard globe valve.
3. A strainer of the “Y” type, with 30 to 40 mesh screen, must be on the inlet line of the pump. (Mesh size indicates the number of openings per lineal inch). A 10x pipe diameter before the pump is recommended.
4. Use a flexible connection in the pump inlet and outlet piping to compensate for piping strains.
5. Use an eccentric swage at the pump inlet nozzle to change the line size (flat side up).
6. Make the inlet line level or slope it downward to the pump.

3.2 The Outlet Piping Should Include the Following

1. A liquid filled pressure gauge should be installed in the pump outlet or near it. A pressure gauge is necessary to determine the efficiency of your pumping system.
2. A hydrostatic relief valve is required by most state laws and for your own safety.

- If the outlet piping exceeds 50 ft (15.2 m) in length, a check valve should be installed in the discharge line near the pump outlet.

3.3 The Bypass System Must Include the Following

- If the pump discharge is shut off before the driver has stopped, a dangerously high pressure can develop; therefore, an external bypass valve must be installed. The installation of an external bypass valve permits the pump to discharge its full capacity back to the supply tank at a predetermined pressure. NOTE: Even though the pump may have an internal relief valve, it is not a substitute for an **external** bypass valve. The internal relief valve is a safety relief valve for the pump only and not the entire system.
- Always install a Corken ZV200 or B177 external bypass valve in the discharge line of pump. The bypass valve may discharge into the supply tank at any convenient liquid or vapor opening; however, it should not connect to the pump inlet piping.

3.4 A Vapor Equalizing System Should be Included

To obtain maximum performance from your Coro-Vane® pump, a vapor equalizing system should be installed. This system is simply a pipe connecting the vapor sections of the tank being unloaded and the tank being filled. This equalizing line allows vapor to move freely between the two tanks (in either direction) and assures that both tanks remain at the same pressure.

As liquid is withdrawn from a tank, it must be replaced by an equal amount of vapor or the pressure in the tank will drop. If an equalizing line is not present, this vapor is formed by “boiling” of the liquid and a reduction of the tank’s pressure. Meanwhile, the tank being filled experiences a pressure increase as the rising fluid levels compresses the vapor space above it. A vapor equalizing line will eliminate both of these problems and will reduce pumping time, differential pressure, noise and wear on the entire system. Slow transfer rates will minimize these effects, and reduce the need for a vapor equalizing line. However, today’s high transfer rates require that a vapor equalizing line be installed.

Another way to consider this principle is to remember that it takes two holes in an oil can for oil to be poured smoothly from the can; one for the oil to exit and the other for the air to enter.

3.5 Driver Installation

The wiring of your electric motor is extremely important and must be done by a competent electrical contractor. The following wire sizing chart indicates the minimum standards for wire sizes.

Improper motor wiring will cause expensive motor difficulties from low voltage. If you suspect you have low voltage, call your power company. Connecting your motor for the voltage you have available is important too. The motors furnished with the stationary pumps are usually dual voltage, so you must be sure of the voltage your power company is supplying you. Your motor will be completely ruined if it is connected to the wrong voltage.

A humid climate can cause problems, particularly in explosion proof motor applications. The normal breathing of the motor, and alternating between being warm when running and cool when stopped, often will cause moist air to be drawn into the motor housing. This moist air will condense, and may eventually add enough free water to the inside of the motor to cause it to fail. To prevent this, make a practice of running the motor and pump at least once a week on a bright, dry day for an hour or so (pumping through the bypass system). In this period the motor will heat up and vaporize the condensed moisture, and drive it out of the motor. No motor manufacturer will guarantee an explosion-proof or totally enclosed motor against damage from moisture.

Engine drivers pose a special consideration. The manufacturer’s instructions must be followed. When the stationary pump is equipped with an engine from the factory, the engine speed should normally not exceed 1,800 RPM. Excessive engine speed will overload the engine and cause early failure. The engine loses 3% of its power for every 1,000 ft (305 m) above sea level, so if your installation is at a higher altitude than normal, consult the factory.

Hp	Motor			Recommended wire size, AWG ¹		
	Motor phase	Volts	Approximate full load amperes	Length of run (ft)		
				0–100	to 200	to 300
3	1	115	34.0	6	4	2
		220	17.0	12	8	8
	3	230	9.6	12	12	12
		460	4.8	12	12	12
5	1	115	56.0	4	1	1/0
		230	28.0	10	6	4
	3	230	15.2	12	12	10
		460	7.6	12	12	12
7-1/2	1	230	40.0	8	6	4
		230	22.0	10	10	8
	3	450	11.0	12	12	12
10	3	230	28.0	8	8	8
		460	14.0	12	12	12
15	3	230	42.0	6	6	6
		460	21.0	10	10	10
20	3	230	54.0	4	4	4
		460	27.0	8	8	8
25	3	230	68.0	2	2	2
		460	34.0	6	6	6
30	3	230	80.0	1	1	1
		460	40.0	6	6	6
40	3	230	100.0	2/0	2/0	2/0
		460	52.0	4	4	4
50	3	230	130.0	3/0	3/0	3/0
		460	65.0	2	2	2

¹Based upon 3% voltage loss copper wire type TW. Single phase motor calculations are based on two times distance.

Chapter 4—Operation of the Z-Series Stationary Coro-Vane® Pump

Performance curves and charts are provided in Appendix C.

The following steps should be performed for the initial pumping operation:

1. Verify the strainer screen is clean.
2. Rotate the pump by hand.
3. Check V-belt drive or direct drive coupling alignment. Misalignment will cause accelerated wear of the drive system, motor bearings, and pump.
4. Check motor for proper wiring.
5. Review complete system to make certain the function of every valve and piece of equipment is clearly understood. Everyone operating this system must be properly trained in normal operating procedures and emergency procedures in event of a malfunction.
6. Close all hose valves.
7. Slowly open the storage tank bottom shut-off valve (suction line to the pump). Immediately check the system for leaks.
8. Open any shut-off valves between the bypass valve and the storage tank.
9. Make a note of all pressure gauge readings, especially the pressure gauge located at the discharge of the pump. Start the pump and circulate the liquid through the bypass system back to the storage tank.
10. Verify the proper pump rotation direction. There is an arrow cast in the pump case.
11. An ampmeter may be used by adjusting the bypass valve until the ampmeter indicates the full load motor amperage rating shown on the motor nameplate or maximum rated differential, whichever comes first. Permit the pump to circulate liquid for half an hour or more. If the motor overload protection device stops the motor in this period the bypass valve setting is too high and should be readjusted until the motor will run for half an hour. After a satisfactory setting is achieved, “seal” the valve adjusting stem to prevent tampering with the adjustment. See Important Instructions (IH102) and Installation, Operation and Maintenance (IOM) Manual (IH106) for more details on the use of the Corken bypass valves.
12. Your pump has an internal relief valve, it must be set higher than the external bypass setting. The internal relief valve is factory preset.
13. After initial operation, re-check the strainer screen.

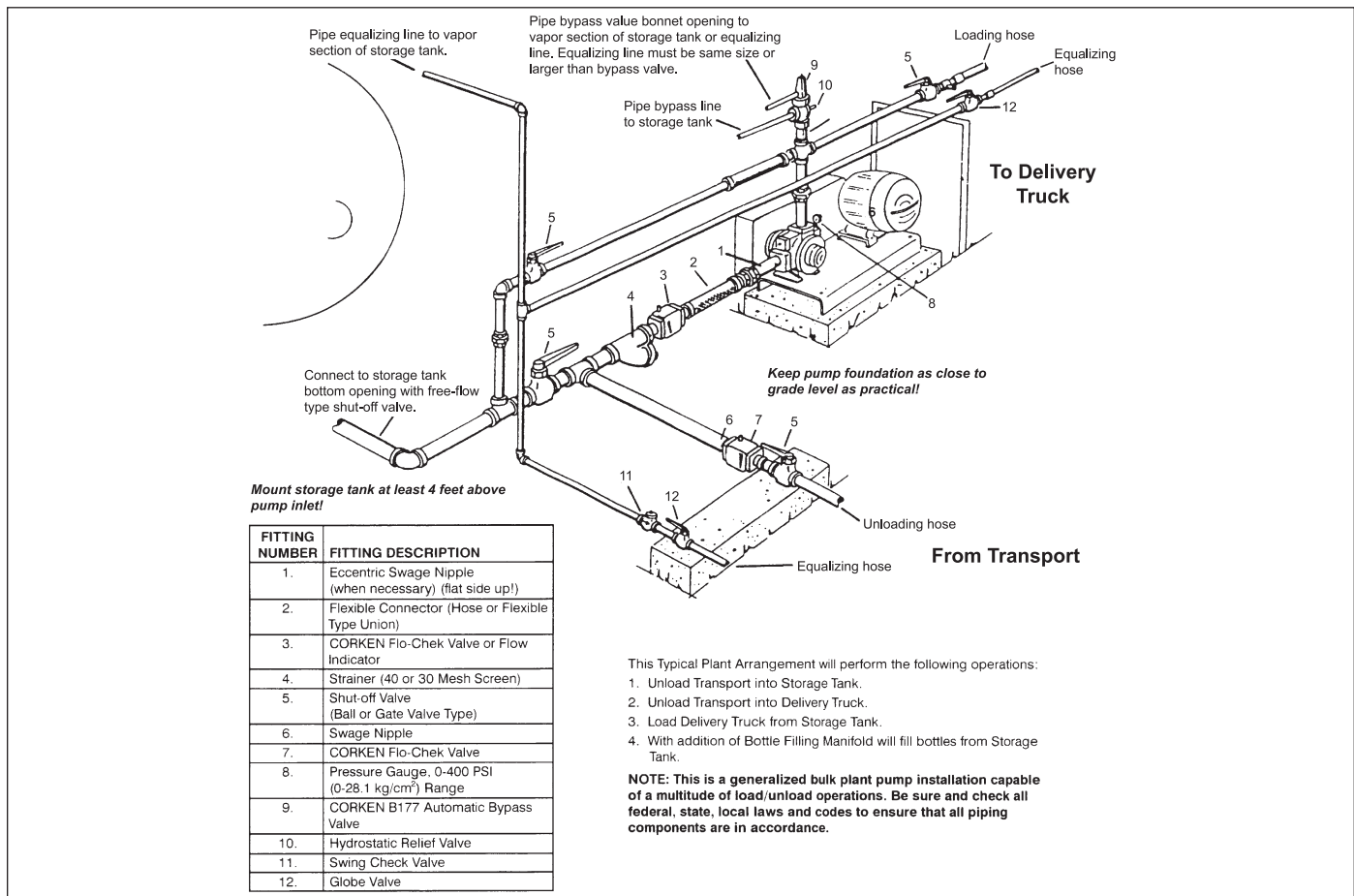

Figure 4.1

Chapter 5—Maintenance of the Z-Series Coro-Vane® Pump

5.1 Purpose

By following an effective maintenance program, unscheduled downtime can be eliminated. This program should be used by the Operation Manager to get a maximum utilization of manpower and equipment as well as to prevent possible unsafe situations and/or production delays due to equipment breakdown.

Normal wear parts are the mechanical seals, bearings, vanes, and sideplates. All of these parts, plus O-rings and grease seals, are offered in the Corken “repair kit” listed in this manual directly after the Seal Replacement Instructions. Use only genuine Corken replacement parts when repairing the Z-Series pump. Follow the instructions provided with the parts.

5.2 Scope

The Pump Maintenance Schedule table below includes the items to be regularly checked and inspected with a recommended time schedule. These are basic maintenance recommendations, and each company should develop their own comprehensive preventive maintenance program schedule, tailor-made to their individual operational procedures and requirements.

Pump Maintenance Schedule

	Daily	Monthly	3 Months
Lubricate bearings		X	
Inspect drive coupling			X
Clean inlet strainer		X	
Check for leaks	X		
Inspect hose and fittings	X		

Maintenance must only be performed by a properly trained and qualified individual that follows all the applicable safety procedures.

5.3 Procedures

 **ALL REPAIRS TO THE PUMP MUST BE PERFORMED BY QUALIFIED PERSONNEL IN A SAFE MANNER, UTILIZING TOOLS AND/OR EQUIPMENT THAT ARE FREE OF HAZARDS, AND FOLLOWS THE APPLICABLE SAFETY CODES OF PRACTICE SET BY THE LOCAL AUTHORITIES HAVING JURISDICTION. MAKE SURE THE SYSTEM PRESSURE HAS BEEN RELIEVED BEFORE ATTEMPTING ANY REPAIR TO THE PUMP.**

Your Corken Z-Series Pump requires regular maintenance and care like all mechanical equipment. A neglected or improperly repaired pump will result in premature failure and cause unsafe conditions. To promote product longevity and safety, maintenance must be performed by properly trained technicians. Make sure all safety systems are in place and the system pressure has been relieved before attempting **ANY** maintenance.

Make sure the transfer hoses are not “kinked” which can cause excessive pump discharge pressure. Always make sure your hoses are not out of date.

When it becomes necessary to repair your pump or remove it from the system, you must be absolutely certain that all propane, anhydrous ammonia, or whatever product being pumped is bled from the pump and connecting piping. Once all the product has safely been bled from the pump and connecting piping, make certain no pressure is left in the system. **SPECIAL CARE MUST BE TAKEN DURING THE BLEED DOWN PROCESS TO AVOID DANGER TO PERSONNEL AND PROPERTY IN THE AREA.** Bleeding a system too fast is a common mistake and may result in “refrigerated” liquid being left in the pump and piping even though the pressure gauge shows no pressure. As the “refrigerated” liquid begins to warm, more gas will escape causing a dangerous condition. Take your time in bleeding your system and make proper provisions to vent or capture the gas in accordance with local regulations.



NOTE: ONLY A PROPERLY TRAINED INDIVIDUAL SHOULD BE ALLOWED TO BLEED A PUMPING SYSTEM.

1. Visual Inspection:

This includes checking for leaks, corroded areas, condition of hoses, piping and fittings, and any unsafe condition which may hinder the safety of the personnel and/or the facility.

2. Clean Inlet Strainer Screen:

A clogged strainer screen will create too much flow restriction and vapor will be formed causing the pump to cavitate. This reduces the pump’s capacity and accelerates the wear of the internal parts.

3. Inspect Drive Coupling and Driveline:

Check the coupling alignment and the condition of the union for cuts, broken sections and wear.

4. Lubricate Pump Bearings:

There are two lubrication points on the Z-Series pumps. A grease zerk is located on the top of each bearing cap. To prevent over greasing the bearings, a grease relief fitting is located on the bottom of each

bearing cap. Always clean each grease zerk and relief fitting before lubricating the bearings. This practice helps prevent foreign material from reaching the bearings through the grease zerk and ensures the grease relief fitting is not blocked. If the grease relief fitting is blocked, the excessive grease that cannot be relieved may cause premature seal failure. If you use a hand grease gun, put the grease in slowly and stop as soon as the relief fitting opens. Grease the U-joints and the spline of the drive shaft when greasing the pump.

NOTE: Always use ball bearing grease (MIL-G-10924C) with a temperature rating of -65°F.

5. Lubricate Motor Bearing:

If lubrication is required, follow the recommendations of the electric motor manufacturer for the type of grease to use and the lubrication frequency.

6. Performance Test:

- a. While transferring liquid with the pump, check the pressure at the pump's inlet port. The pressure drop in the inlet piping should not be greater than 3 psi.

- b. While transferring liquid with the pump, close the discharge valve(s) so the full flow will be directed back to the storage tank through the bypass valve. Then slowly close the valve downstream of the bypass valves. The discharge pressure of the pump should increase to the maximum differential pressure of the pump at no flow conditions (see Appendix C: Performance Curves).

- c. If the maximum differential pressure is not obtained, the pump must be serviced. See Appendix G Troubleshooting Guide for additional help.

- d. Replace vanes or sideplates if worn.

7. Tighten all holddown bolts.

8. Inspect motor starter contact points.

This must be performed by an authorized and qualified electrician, based on the electric motors manufacturer's guidelines.

Chapter 6—Z-Series Coro-Vane® Seal Replacement Instructions

Please Note: The photos listed below contain a Z2000; however, all Z-Series pumps use the same procedures for seal replacement.

To determine the parts needed for repair, refer to Appendix A—Model Number and Identification Code, and Appendix E—Parts Details.



CAUTION! BLEED ALL PRESSURE FROM THE PUMP AND PIPING BEFORE STARTING TO INSTALL YOUR SEAL ASSEMBLY.

Cleanliness

Even the smallest amount of dirt on your new seal can cause early failure. Keep all parts, tools and your hands clean while installing the seal. Never touch the smooth lapped faces of the carbon rotor or seal seat. For LP-Gas, anhydrous ammonia and similar liquids, you are trying to seal a fluid that is 5 to 10 times thinner than water! Your new seal needs every chance it can get, so keep it clean.

Workmanship

Your Corken pump is a precision piece of equipment with very close clearances. Treat it as such. Never use force during assembly or disassembly (see steps 1 through 10).

Step 1

Depressurize and open the pump



Loosen the head bolts and remove one head with the bearing cap attached, while holding in on the shaft.

Step 2

Remove the seal seat and grease seal

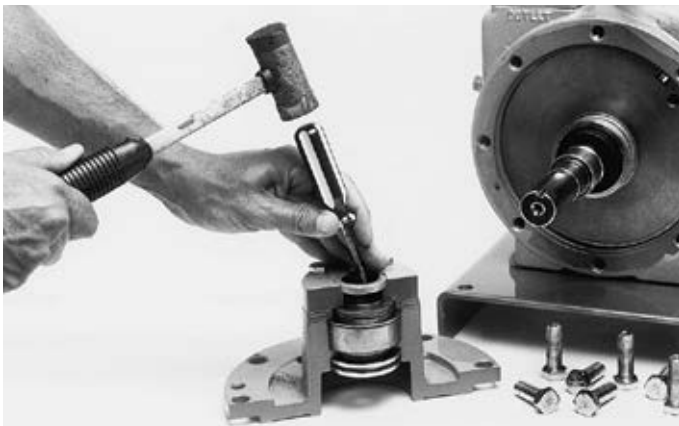

NOTE: The photo above is using a cutaway view for better details.

After the head has been removed from the pump, remove the head O-ring and place to the side. Place the head on

the workbench as shown in the photo. When replacing the seal assembly, there is no need to remove the bearings. With a long screwdriver, reach through the opening of the bearing cap and lightly tap the seal seat until it falls out of the head. The seal seat is located at the bottom of the head. Next, remove the grease seal using same process. The old seal seat and grease seal will not be reused.

Step 3

Install the new grease seal



NOTE: The photo above is using a cutaway view for better details.

Turn the head over as shown in the photo and install the new grease seal smooth side up by pressing into the bore next to the main bearing. To assist with the installation of the grease seal, place the old seal seat without the O-ring over the top of the grease seal and press into place as show in the photo. The grease seal should fit flush with the shoulder of the bore (see Figure 6.1 for details).

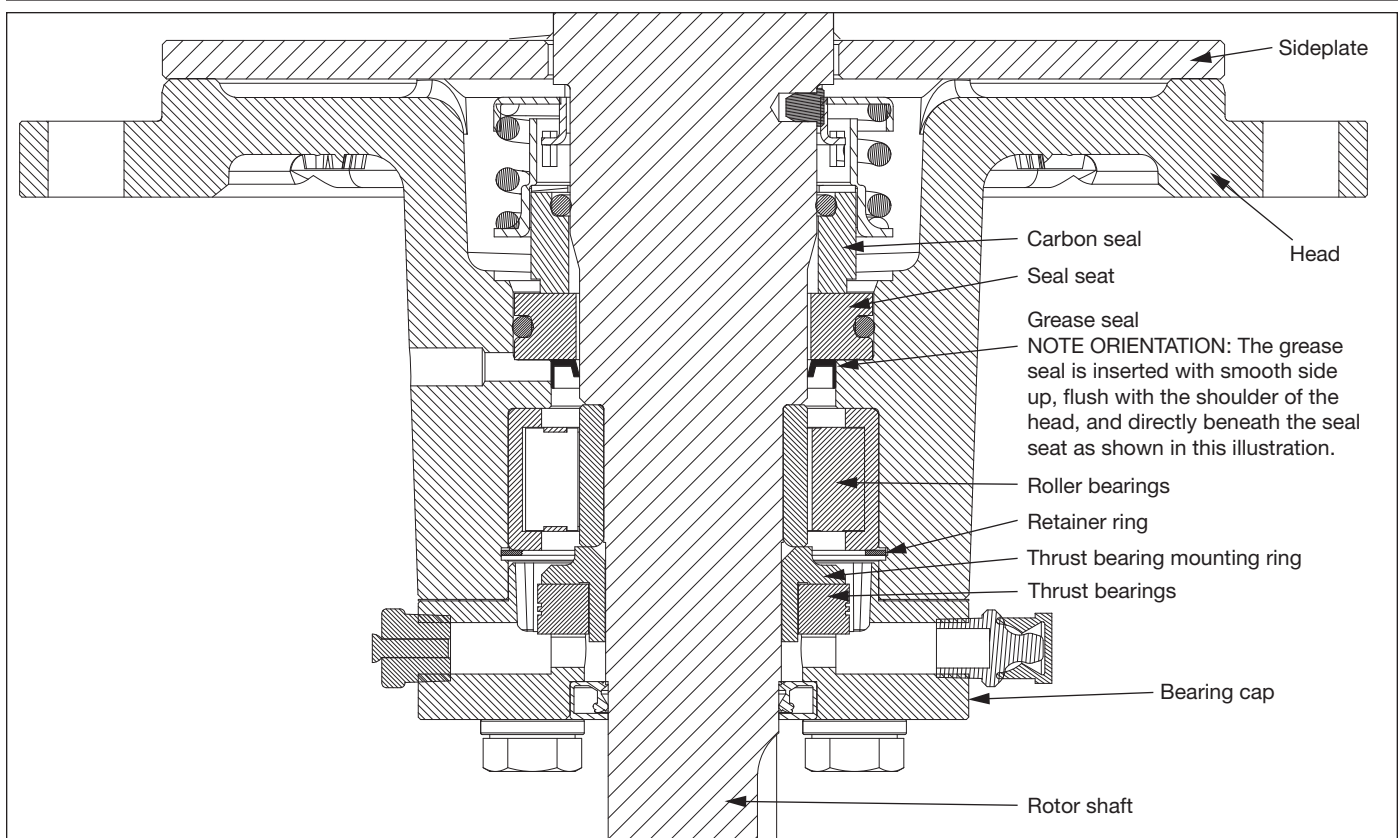

Figure 6.1

Step 4

Install the new seal seat



NOTE: The photo above is using a cutaway view for better details.

Be careful not to touch the smooth, shiny surfaces of the seal seat. The smooth shiny surfaces must stay clean at all times. Foreign material on these surfaces can cause seal failure. Before installing the new seal seat, spray or apply a generous amount of light oil to the new seal seat and O-ring. This will allow the O-ring on the outside of the seal seat to easily slide into place during installation. Before you press the seal seat in place, make sure you cover the seal seat with the protective cardboard disc as shown in the photo.

Step 5

Remove the old seal assembly (carbon seal and retainer)

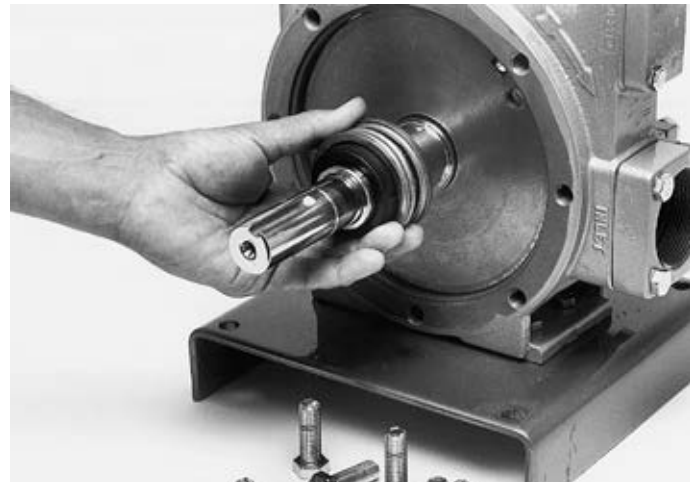

Remove the old seal assembly from the pump shaft while holding the sideplate against the pump casing. This will allow the seal retainer assembly to be removed without pulling the rotor-shaft out of the pump. Inspect the rotor shaft for burrs or scratches. If present remove with an emery or polishing cloth.

Step 6

Install the new seal assembly (retainer and carbon)



Clean the pump shaft and apply a generous amount of light oil to the shaft and seal assembly.

Install the new seal assembly by aligning the seal retainer slot with the seal drive pin on the shaft.

Step 7

Mechanical seal installation

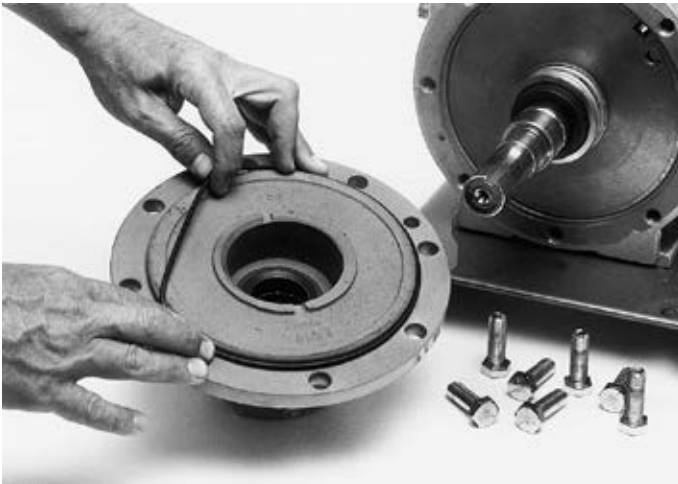

Install the new case O-ring onto the head.

Apply a generous amount of light oil to each seal face and carefully install the head assembly over the pump shaft.

Step 8

Completing installation

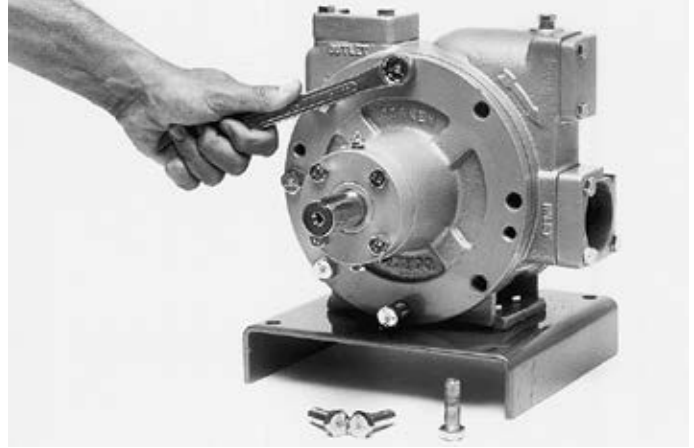

Torque the head bolts in a crossing pattern. There is no need to disassemble or re-shim the bearing caps. Repeat all of the above steps when replacing the seal assembly on the opposite side.

Step 9

Lubrication and re-pressurizing

Note: Both sides of the pump are identical; duplicate procedure to change the seal on the opposite side.

Lubrication

There are two lubrication points on the Z-Series pumps. A grease zerk is located on each bearing cap. To prevent over greasing the bearings, a grease relief fitting is located on the opposite side of each bearing cap. Always clean each grease zerk and relief fitting before lubricating the bearings. This practice helps prevent foreign material from reaching the bearings through the grease zerk and ensures the grease relief fitting is not blocked. If the grease relief fitting is blocked, the excessive grease that cannot be relieved may cause premature seal failure.

If you use a hand grease gun, put the grease in slowly and stop as soon as the relief fitting opens. Grease the U-joints and the spline of the drive shaft when greasing the pump.

NOTE: Always use ball bearing grease (MIL-G-10924C) with a temperature rating of -65°F.

Re-pressurize

For best results, slowly pressurize with vapor pressure.

Please Note: If you pressurize with liquid, it will sometimes refrigerate even though it enters the pump slowly. As a result, the seal elastomers will not seal properly thereby causing them to leak.

6.1 Repair/Rebuild Kits with Iron Seal Seat

Repair Kit 3193-X1 (Z2000, ZH2000, ZX2000, ZXH2000)

2-224A	O-ring, Buna-N	1
2-231A	O-ring, Buna-N	2
2754-X	Roller bearing	2
4262-X	Vane driver	3
4428	Vane	6
4431-XA2	Seal assembly	2
4432	Thrust bearing	2
4435	Thrust bearing mounting ring	2
4439	Bearing cap shim (0.002)	8
4439-1	Bearing cap shim (0.010)	2
4439-2	Bearing cap shim (0.020)	2
4441	Grease seal	2
2270	Shaft key	1

Repair Kit 3195-X1 (Z3200, ZH3200)

2-224A	O-ring, Buna-N	1
2-234A	O-ring, Buna-N	2
2754-X	Roller bearing	2
4262-X	Vane driver	3
4232	Vane	6
4431-XA2	Seal assembly	2
4432	Thrust bearing	2
4435	Thrust bearing mounting ring	2
4439	Bearing cap shim (0.002)	8
4439-1	Bearing cap shim (0.010)	2
4439-2	Bearing cap shim (0.020)	2
4441	Grease seal	2
2270	Shaft key	1

Repair Kit 3195-X2 (Z3500)

2-228A	O-ring, Buna-N	2
2754-X	Roller bearing	2
5554-X	Vane driver	6
3936	Vane	6
6660-XA2	Seal assembly	2
4432	Thrust bearing	2
4435	Thrust bearing mounting ring	2
4439	Bearing cap shim (0.002)	8
4439-1	Bearing cap shim (0.010)	2
4439-2	Bearing cap shim (0.020)	2
4441	Grease seal	2
2270	Shaft key	1

Repair Kit 3197-X1 (Z4200, ZH4200, Z4500)

2-231A	O-ring, Buna-N	2
2-234A	O-ring, Buna-N	1
4460-X	Roller bearing	2
4449-X	Vane driver	5
4448	Vane	6
4464-XA2	Seal assembly	2
4453	Thrust bearing	2
4454	Thrust bearing mounting ring	2
4458	Bearing cap shim (0.002)	8
4458-1	Bearing cap shim (0.010)	2
4458-2	Bearing cap shim (0.020)	2
4463	Grease seal	2
4459	Shaft key	1

Rebuild Kit 3194-X1 (Z2000, ZH2000, ZX2000, ZXH2000)

Includes all items in the Repair Kit plus the following:

4414	Cam	1
4427	Sideplate	2

Rebuild Kit 3196-X1 (Z3200, ZH3200)

Includes all items in the Repair Kit plus the following:

4242	Cam	1
4231	Sideplate	2

Rebuild Kit 3196-X2 (Z3500)

Includes all items in the Repair Kit plus the following:

5539	Cam	1
3935	Sideplate	2

Rebuild Kit 3198-X1 (Z4200, ZH4200, Z4500)

Includes all items in the Repair Kit plus the following:

4443	Cam	1
4446	Sideplate	2

Full Rebuild Kit 3194-X3 (Z2000, ZH2000, ZX2000, ZXH2000)

Includes all items in the Repair Kit plus the following:

4414	Cam	1
4427	Sideplate	2
4430-X2R	Rotor shaft assembly	1

Full Rebuild Kit 3196-X3 (Z3200, ZH3200)

Includes all items in the Repair Kit plus the following:

4242	Cam	1
4231	Sideplate	2
4495-X2R	Rotor shaft assembly	1

Full Rebuild Kit 3196-X4 (Z3500)

Includes all items in the Repair Kit plus the following:

5539	Cam	1
3935	Sideplate	2
1208-1X6R	Rotor shaft assembly	1

Full Rebuild Kit 3198-X3 (Z4200, ZH4200, Z4500)

Includes all items in the Repair Kit plus the following:

4443	Cam	1
4446	Sideplate	2
4444-X2R	Rotor shaft assembly	1

All repair and rebuild kits have Buna-N O-rings which are suitable for both LPG and NH₃ applications.

6.2 Repair/Rebuild Kits with Silicon Carbide Seal Seat

Repair Kit 3193-X16 (Z2000, ZH2000, ZX2000, ZXH2000)

2-224A	O-ring, Buna-N	1
2-231A	O-ring, Buna-N	2
2754-X	Roller bearing	2
4262-X	Vane driver	3
4428	Vane	6
4431-XA6	Seal assembly	2
4432	Thrust bearing	2
4435	Thrust bearing mounting ring	2
4439	Bearing cap shim (0.002)	8
4439-1	Bearing cap shim (0.010)	2
4439-2	Bearing cap shim (0.020)	2
4441	Grease seal	2
2270	Shaft key	1

Repair Kit 3195-X16 (Z3200, ZH3200)

2-224A	O-ring, Buna-N	1
2-234A	O-ring, Buna-N	2
2754-X	Roller bearing	2
4262-X	Vane driver	3
4232	Vane	6
4431-XA6	Seal assembly	2
4432	Thrust bearing	2
4435	Thrust bearing mounting ring	2
4439	Bearing cap shim (0.002)	8
4439-1	Bearing cap shim (0.010)	2
4439-2	Bearing cap shim (0.020)	2
4441	Grease seal	2
2270	Shaft key	1

Repair Kit 3195-X26 (Z3500)

2-228A	O-ring, Buna-N	2
2754-X	Roller bearing	2
5554-X	Vane driver	6
3936	Vane	6
6660-XA6	Seal assembly	2
4432	Thrust bearing	2
4435	Thrust bearing mounting ring	2
4439	Bearing cap shim (0.002)	8
4439-1	Bearing cap shim (0.010)	2
4439-2	Bearing cap shim (0.020)	2
4441	Grease seal	2
2270	Shaft key	1

Repair Kit 3197-X16 (Z4200, ZH4200, Z4500)

2-231A	O-ring, Buna-N	2
2-234A	O-ring, Buna-N	1
4460-X	Roller bearing	2
4449-X	Vane driver	5
4448	Vane	6
4464-XA6	Seal assembly	2
4453	Thrust bearing	2
4454	Thrust bearing mounting ring	2
4458	Bearing cap shim (0.002)	8
4458-1	Bearing cap shim (0.010)	2
4458-2	Bearing cap shim (0.020)	2
4463	Grease seal	2
4459	Shaft key	1

Rebuild Kit 3194-X16 (Z2000, ZH2000, ZX2000, ZXH2000)

Includes all items in the Repair Kit plus the following:

4414	Cam	1
4427	Sideplate	2

Rebuild Kit 3196-X16 (Z3200, ZH3200)

Includes all items in the Repair Kit plus the following:

4242	Cam	1
4231	Sideplate	2

Rebuild Kit 3196-X26 (Z3500)

Includes all items in the Repair Kit plus the following:

5539	Cam	1
3935	Sideplate	2

Rebuild Kit 3198-X16 (Z4200, ZH4200, Z4500)

Includes all items in the Repair Kit plus the following:

4443	Cam	1
4446	Sideplate	2

Full Rebuild Kit 3194-X36 (Z2000, ZH2000, ZX2000, ZXH2000)

Includes all items in the Repair Kit plus the following:

4414	Cam	1
4427	Sideplate	2
4430-X2R	Rotor shaft assembly	1

Full Rebuild Kit 3196-X36 (Z3200, ZH3200)

Includes all items in the Repair Kit plus the following:

4242	Cam	1
4231	Sideplate	2
4495-X2R	Rotor shaft assembly	1

Full Rebuild Kit 3196-X46 (Z3500)

Includes all items in the Repair Kit plus the following:

5539	Cam	1
3935	Sideplate	2
1208-1X6R	Rotor shaft assembly	1

Full Rebuild Kit 3198-X36 Z4200, ZH4200, Z4500)

Includes all items in the Repair Kit plus the following:

4443	Cam	1
4446	Sideplate	2
4444-X2R	Rotor shaft assembly	1

All repair and rebuild kits have Buna-N O-rings which are suitable for both LPG and NH₃ applications.

6.3 Assembly Instructions For All Z-Series Repair and Rebuild Kits

1. Place the pump head on a clean work surface with the bolting flange down.
2. Press the inner grease seal in through the main bearing cavity until flush with the bottom of the bore. Seal lips must be oriented down as shown in each parts detail drawing. (See Figure 6.1)
3. Press the main bearing into the head and install the retainer ring.
4. Install the relief fitting into 1/8 in. NPT threaded hole and turn the head over.
5. After lubricating the mechanical seal seat with light oil, press the seal seat into the head using your fingers. Make sure the seal seat is fully seated and the shiny side faces up. Apply a generous amount of light oil to the seal seat to remove any remaining debris and fingerprints. Install the case O-ring around the pilot OD of the head.
6. Press the outer grease seals into each of the bearing caps.
7. Press the spring pins into each of the cam key holes.
8. Install the cam key into the pump case. Slide the cam into the pump case aligning the long inlet slots to the inlet portion of the case.
9. Install one sideplate and bolt one head into place with two bolts.
10. Turn the pump onto the assembled head. Ensure there is enough room to allow the shaft to extend through the assembled head by six inches.
11. While holding the rotor-shaft vertical, install the vane drivers. Vertically install the rotor-shaft into the unit. Slide the vanes into each rotor slot ensuring the rounded tip contacts the cam and the vane slots face into the direction of rotation as shown in each parts detail drawing.
12. Install the remaining sideplate.
13. Lubricate the pump shaft and seal carbon with light oil. Install the seal retainer assembly by aligning the retainer slot onto the seal alignment pin. Carefully press the seal carbon into the retainer assembly with the polished face oriented outward by aligning the carbon notches to the retainer pins. Again, apply a generous amount of light oil to remove any remaining debris and fingerprints.
14. Carefully install the head over the pump shaft and seal assembly and torque the bolts in accordance with the appropriate bolt torque pattern drawing. This pattern ensures even bolting of the head into the case without deforming the cam inlet port. This is done by bolting those bolts over the solid portion of the cam port.
15. Turn the pump over and remove the first head.
16. Install the seal retainer assembly and carbon as outlined in step 13 above.
17. Bolt head to case as described in step 14 above. Ensure the rotor shaft turns freely in either direction.
18. Slide the bearing race mounting ring onto one end of the shaft until contact with the main bearing inner race. Mount the thrust bearing assembly onto the bearing race mounting ring and install the bearing cap.
19. Lightly tighten the bearing cap with two opposed bolts until the rotor shaft cannot be freely turned. Measure the gap between the head and bearing cap at four points around the bearing cap. Adjustment may be necessary to contain the gap within .001 inch. Round up the average measurement to the nearest even number. This is the measured amount of bearing cap shims. Refer to parts pages for shim measurements.
20. Remove the two bearing cap bolts and install the measured amount of shims plus .006 inch. Install the four bearing cap bolts and torque in a crossing pattern.
21. Install the remaining bearing race mounting ring and thrust bearing assembly on the opposite side of the pump.
22. Perform step 19 again on the opposite side and install the measured shims plus .002 inch. Install the four bearing cap bolts and torque in a crossing pattern.
23. Install the shaft key and ensure shaft rotates smoothly.

Appendix A—Z-Series Truck Pumps Model Number and Identification Code

Base Model	Z2000/ZH2000	ZX2000/ZXH2000	Z/ZH3200	Z/ZH4200
Inlet	2" NPT	2" NPT	3" ANSI	4" ANSI
Outlet	2" NPT	2" NPT	2" ell	Dual 2" NPT
Auxiliary Inlet	None	None	2" NPT	2" NPT
Internal Relief	150 psi	175 psi	150 psi	150 psi
Weight Bare Pump lb (kg)	100 (45)	100 (45)	140 (64)	275 (125)

Model Number
Base X X X X X X X

Vane Type	6 Vanes with Vane Drivers	Standard	H
Vanes	GCB-50	Standard	G
O-ring Material	Buna-N	Standard	A
	Neoprene ^{®1}	No charge option	B

¹Registered trademark of the DuPont company.

Seal Seat	Cast Iron	No charge option	—
	Silicon Carbide	Standard	6

Flange Options WF=Slip-on weld flange ell = Elbow All ANSI flanges are 300# • indicates available flange connections

Inlet Flange

Standard	2" NPT	•	•			E
	3" ANSI			•		P
	4" ANSI				•	S
Extra Cost Options	2" WF	•	•			F

Outlet Flange

Standard	2" NPT	•	•		•	E
	2" NPT ell			•		G
No Cost Options	1-1/2" NPT			•		C
	2" NPT			•		E
Extra Cost Options	1-1/2" WF			•		D
	2" WF	•	•	•	•	F
	2" weld ell			•		H

Auxiliary Flange

Standard	2" NPT			•	•	E
	None	•	•			U
	1-1/2" NPT			•		C
No Cost Options	Blind Flange			•	•	T
	1-1/2" WF			•		D
Extra Cost Options	2" WF			•	•	F
	2" NPT ell			•		G
	2" weld ell			•		H

Part Number	Test—Options
3000-X1	Hydrostatic test

Appendix A—Z-Series Stationary Pump Model Number and Identification Code

Base Model	Z3500	Z4500
Inlet	3" NPT (Standard)	4" 300# ANSI
Outlet	3" NPT Elongated (Standard)	3" 300# ANSI
Weight—bare pump lb (kg)	160 (73)	265 (120)

Model Number
Base X X X X X

Vane Type	6 Vanes with Vane Drivers	Standard	H
Vanes	GCB-50	Standard	G
O-ring Material	Buna-N	Standard	A
	Neoprene ^{®1}	No charge option	B

¹Registered trademark of the DuPont company.

Seal Seat	Cast Iron	No charge option	—
	Silicon Carbide	Standard	6

Flange Options WF=Slip-on weld flange ell = Elbow All ANSI flanges are 300# • indicates available flange connections

Inlet Flange

Standard	4" ANSI		•	S
	3" NPT	•		M
No Cost Option	4" NPT	•		Q
Extra Cost Options	3" WF	•		N
	4" WF	•		R

Outlet Flange

Standard	3" ANSI		•	P
	3" NPT Elongated	•		T
Extra Cost Options	3" WF Elongated	•		V

Mounting Options

Description	Model	Part Number	Maximum Driver (hp)	Ship Weight (mounting only) lb
Mounting set up for V-belt drive. Includes steel baseplate, adjustable motor slid base, V-belt drive and enclosed belt guard	Z4500	103-15-	25	630
	Z3500	103-10-	20	560

Part Number	Test—Options
3000-X1	Hydrostatic test

Appendix B—Specifications

Equipment Type & Options

Truck sliding vane pump
Multiple connection options
Optional auxiliary inlet

Applications

Propane bulk transfer Auto-fuel pumping
NH₃ nurse tanks Carousel cylinder filling
LPG cylinders

Features & Benefits

Sliding vane:	Positive displacement
Heavy duty bearings:	Long bearing life
Single mechanical seal:	Very easy seal replacement and maintenance
Built in relief valve (NPT models only):	Factory pre-set—added protection
Pressure gauge connections:	Suction and discharge to reduce piping needs
Reversible side plates:	Longer service life

Operating Specifications

RPM range: 420–800 RPM	Max. differential pressure: 125 psid (8.6 bar d) for Z/ZH2000, Z/ZH3200, Z/ZH4200, and Z4500 150 psid (10.3 bar d) for ZX/ZXH2000 and Z3500
Maximum working pressure:	350 psig (24.1 bar)
Temperature range: -25°F–225°F (-32°C–107°C)	Flow range: 41–400 gpm (155–1,514 L/min)
Internal relief valve: Yes	

Material Specifications

Part	Model	Standard Material	Optional Material
Case, head, rotor, relief-valve cap, bearing cap	All	Ductile iron ASTM A536	
Cam	All	Gray iron ASTM A48, Class 50	
Sideplate	All	Gray iron ASTM A48, Class 30	
Welding flange	All	Steel	
Seal seat	All	Silicon carbide	Stainless steel, Ni-Resist, gray iron
Seal metal parts	Z/ZH/ZX/ZXH2000, Z/ZH3200, Z3500, Z/ZH4200, Z4500	Steel	
Shaft	All	8620 steel	
Vanes and vane drivers	All	Advanced polymers	
Relief valve spring	Z/ZH3200	Steel, cadmium plated	
	Z/ZH/ZX/ZXH2000, Z3500, Z/ZH4200, Z4500	Stainless steel	
Relief valve	Z/ZH3200, Z3500	Steel	
	Z/ZH/ZX/ZXH2000, Z/ZH4200, Z4500	Stainless steel	
Bearing	All	Steel	
Thrust bearing	All	Steel	
O-rings	All	Buna-N	Kalrez ^{®1} , Neoprene ^{®1} , Viton ^{®1}
Retainer rings	All	Steel	

¹Registered trademark of the DuPont company.

Appendix C—Z2000, ZH2000, ZX2000, and ZXH2000 Performance Curves

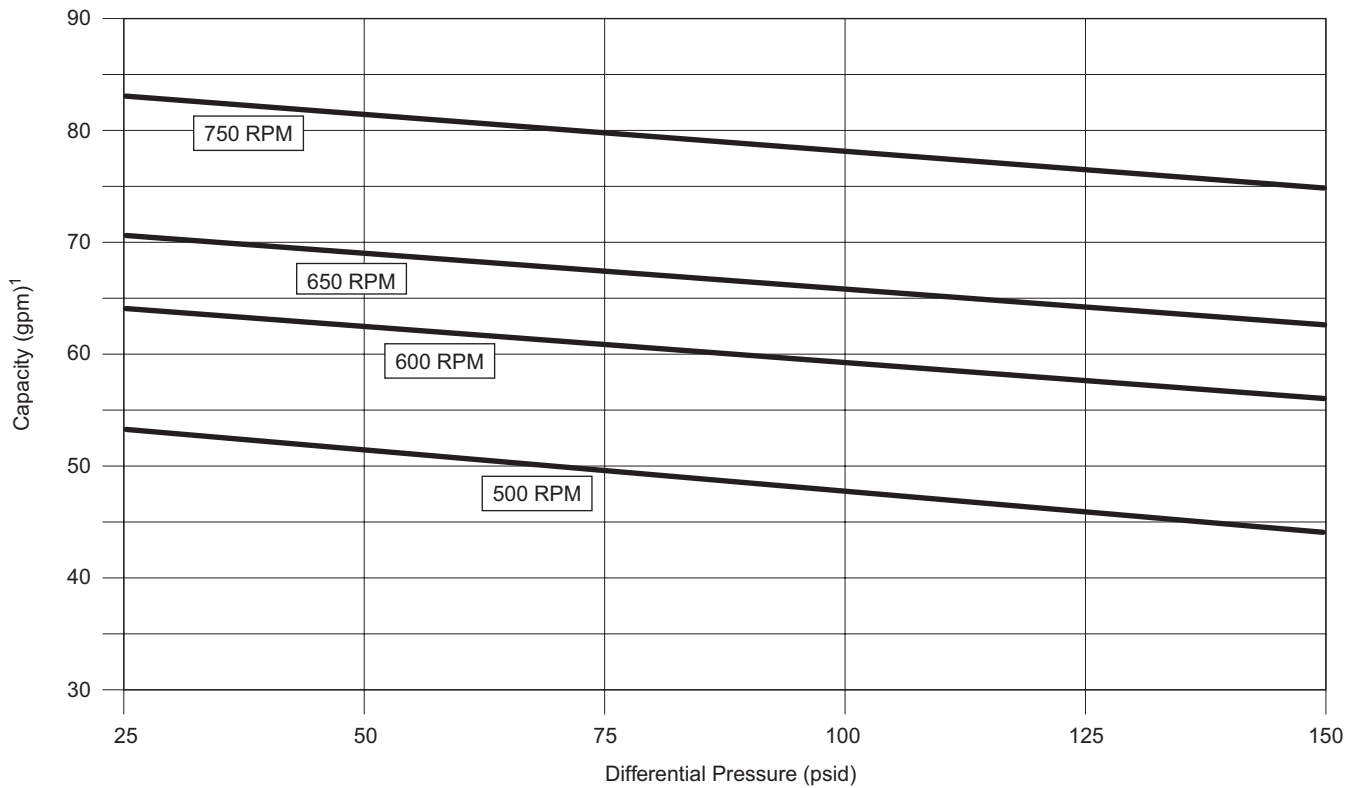

¹The chart shows approximate delivery rates as seen in vapor equalized propane systems at 70°F (21°C) with no pressure loss in pump suction piping. The following will cause increased vaporization of the liquid in the pump suction, adversely affecting the delivery:

1. Restrictions in the suction piping such as internal valves, excess flow valves, elbows, etc.
2. Restriction or lack of a vapor return line
3. Temperatures below 70°F (21°C)

This loss of delivery is not caused by the pump but is a result of the natural thermodynamic properties of liquefied petroleum gases. See the "GUIDE TO CORKEN LIQUEFIED GAS TRANSFER EQUIPMENT" (CP226) for additional information.

Appendix C—Z3200 and ZH3200 Performance Curves

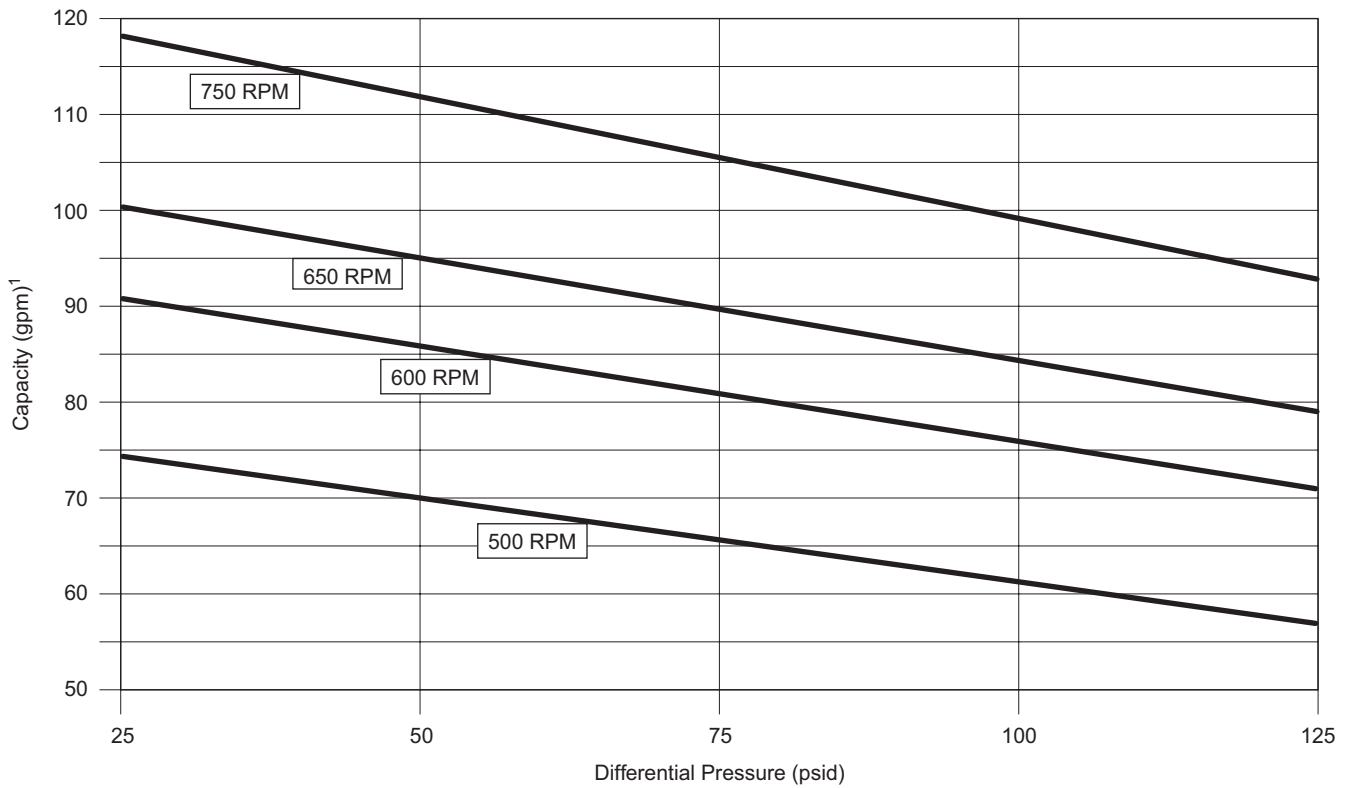

¹The chart shows approximate delivery rates as seen in vapor equalized propane systems at 70°F (21°C) with no pressure loss in pump suction piping. The following will cause increased vaporization of the liquid in the pump suction, adversely affecting the delivery:

1. Restrictions in the suction piping such as internal valves, excess flow valves, elbows, etc.
2. Restriction or lack of a vapor return line
3. Temperatures below 70°F (21°C)

This loss of delivery is not caused by the pump but is a result of the natural thermodynamic properties of liquefied petroleum gases. See the "GUIDE TO CORKEN LIQUEFIED GAS TRANSFER EQUIPMENT" (CP226) for additional information.

Appendix C—Z4200 and ZH4200 Performance Curves

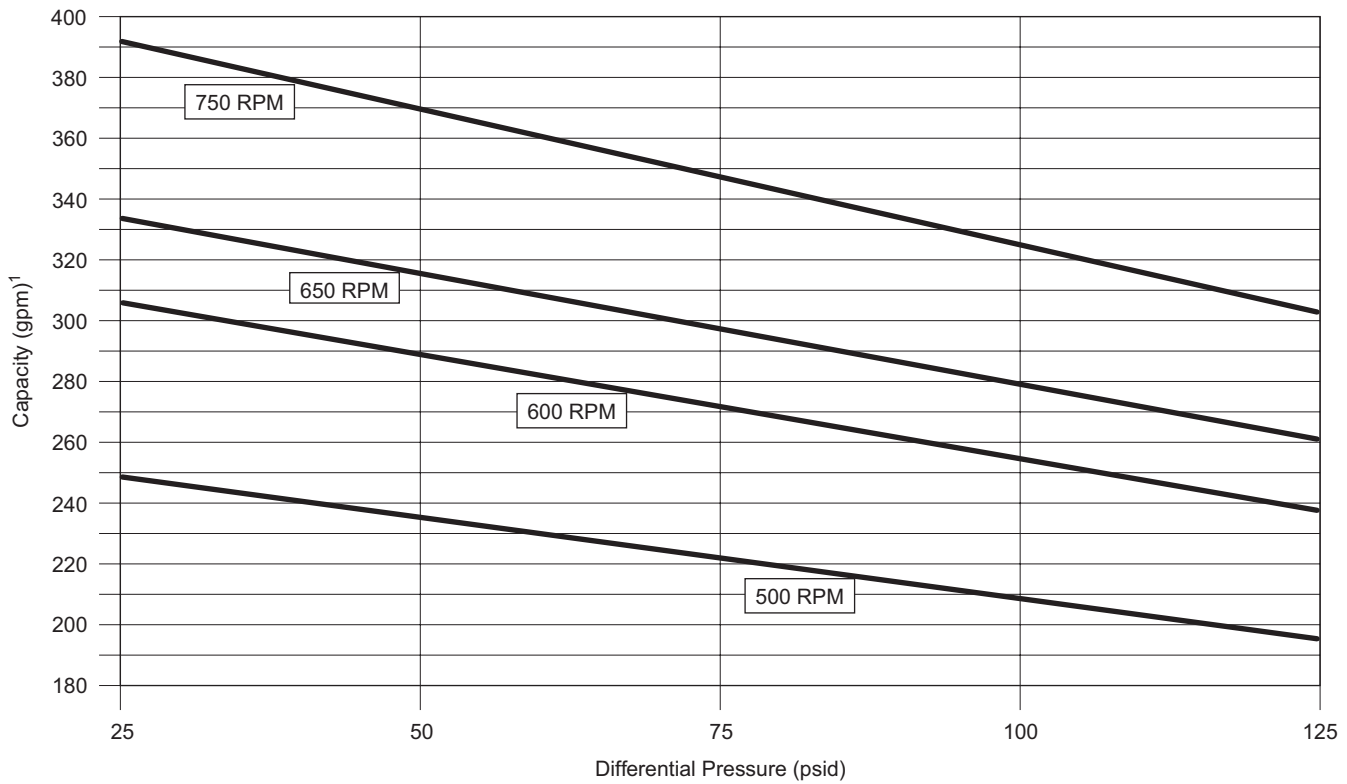

¹The chart shows approximate delivery rates as seen in vapor equalized propane systems at 70°F (21°C) with no pressure loss in pump suction piping. The following will cause increased vaporization of the liquid in the pump suction, adversely affecting the delivery:

1. Restrictions in the suction piping such as internal valves, excess flow valves, elbows, etc.
2. Restriction or lack of a vapor return line
3. Temperatures below 70°F (21°C)

This loss of delivery is not caused by the pump but is a result of the natural thermodynamic properties of liquefied petroleum gases. See the "GUIDE TO CORKEN LIQUEFIED GAS TRANSFER EQUIPMENT" (CP226) for additional information.

Appendix C—Performance Charts

Z2000, ZH2000, ZX2000, and ZXH2000 Coro-Vane® Truck Pumps

Pump Speed	Differential Pressure	Approximate Delivery of Propane ¹	Brake hp Required	Pump Torque Required
RPM	psid (kPa)	gpm (L/min)	bhp (kW)	ft•lb (N•M)
750	50 (345)	82 (309)	2.9 (2.2)	20.4 (27.7)
750	100 (689)	77 (291)	5.8 (4.3)	40.8 (55.3)
750	150 ² (1,034)	75 (284)	8.9 (6.63)	62.2 (84.3)
650	50 (345)	69 (261)	2.5 (1.9)	20.4 (27.7)
650	100 (689)	64 (242)	5.1 (3.8)	40.8 (55.3)
650	150 ² (1,034)	63 (238)	7.7 (5.7)	62.2 (84.3)
600	50 (345)	63 (238)	2.3 (1.7)	20.4 (27.7)
600	100 (689)	58 (219)	4.6 (3.5)	40.8 (55.3)
600	150 ² (1,034)	56 (212)	7.1 (5.3)	62.2 (84.3)
500	50 (345)	52 (197)	1.9 (1.4)	20.4 (27.7)
500	100 (689)	46 (174)	3.9 (2.9)	40.8 (55.3)
500	150 ² (1,034)	44 (166)	5.9 (4.4)	62.2 (84.3)

Z3200 and ZH3200 Coro-Vane® Truck Pumps

Pump Speed	Differential Pressure	Approximate Delivery of Propane ¹	Brake hp Required	Pump Torque Required
RPM	psid (kPa)	gpm (L/min)	bhp (kW)	ft•lb (N•M)
750	50 (345)	112 (424)	6.2 (4.6)	43.4 (58.9)
750	100 (689)	99 (375)	9.9 (7.4)	69.3 (94.0)
650	50 (345)	95 (360)	5.2 (3.9)	42.0 (57.0)
650	100 (689)	84 (318)	8.2 (6.1)	66.3 (89.9)
600	50 (345)	86 (326)	5.0 (3.7)	41.3 (56.0)
600	100 (689)	76 (288)	7.8 (5.9)	64.8 (87.9)
500	50 (345)	70 (265)	3.8 (2.8)	39.9 (54.1)
500	100 (689)	62 (235)	5.8 (4.3)	60.9 (82.6)

Z4200, ZH4200, and Z4500 Coro-Vane® Truck Pumps

Pump Speed	Differential Pressure	Approximate Delivery of Propane ¹	Brake hp Required	Pump Torque Required
RPM	psid (kPa)	gpm (L/min)	bhp (kW)	ft•lb (N•M)
750	50 (345)	369 (1,397)	12.5 (9.3)	87 (118.0)
750	100 (689)	325 (1,230)	25.1 (18.6)	175 (237.3)
650	50 (345)	316 (1,196)	10.8 (8.0)	87 (118.0)
650	100 (689)	278 (1,052)	21.7 (16.1)	175 (237.3)
600	50 (345)	289 (1,094)	9.9 (7.3)	87 (118.0)
600	100 (689)	254 (961)	20.0 (14.8)	175 (237.3)
500	50 (345)	236 (893)	8.3 (6.2)	87 (118.0)
500	100 (689)	208 (787)	16.7 (12.4)	175 (237.3)

¹Delivery times are approximate—see note on page 22 for further explanation.

²Applies to ZX/ZXH2000 models only.

Appendix C—Performance Curves

Z3500

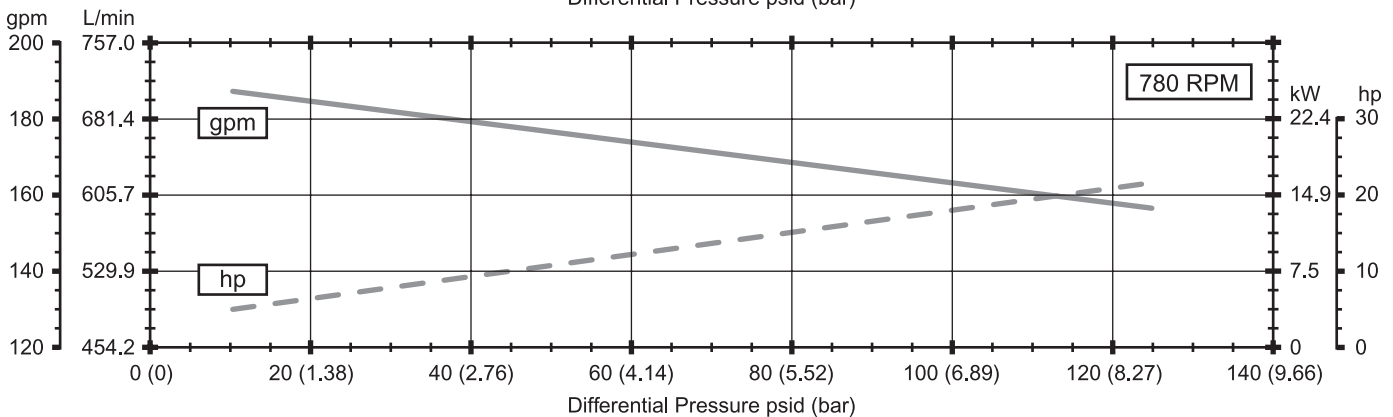
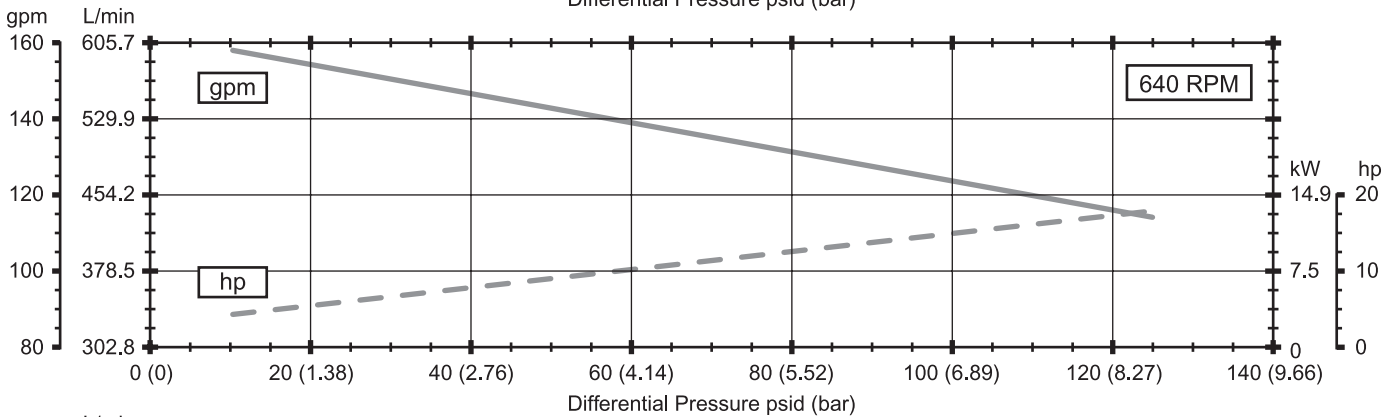
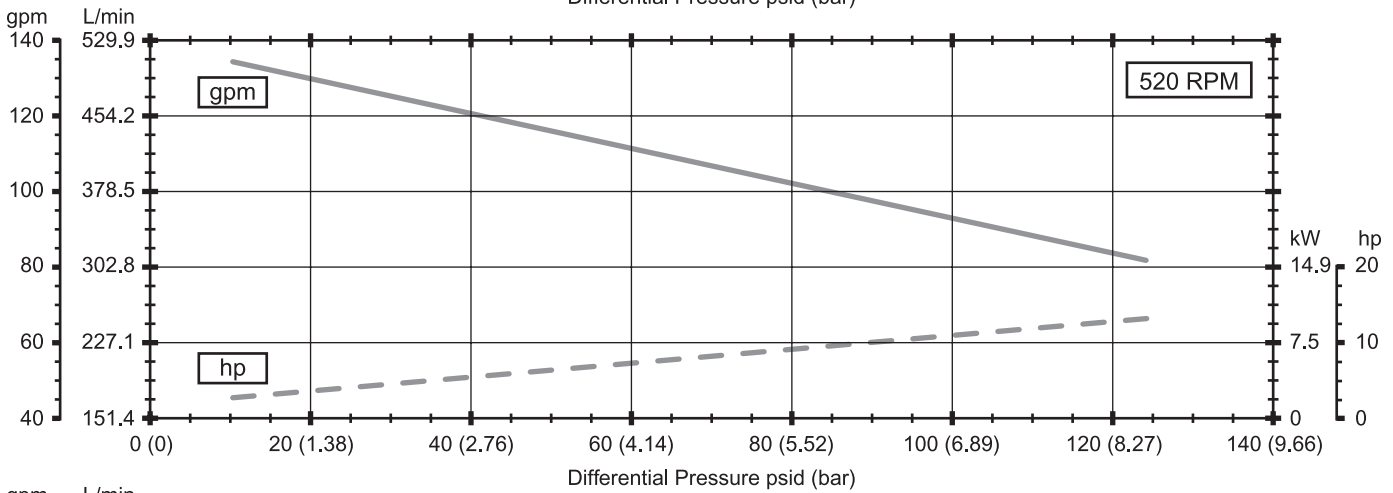
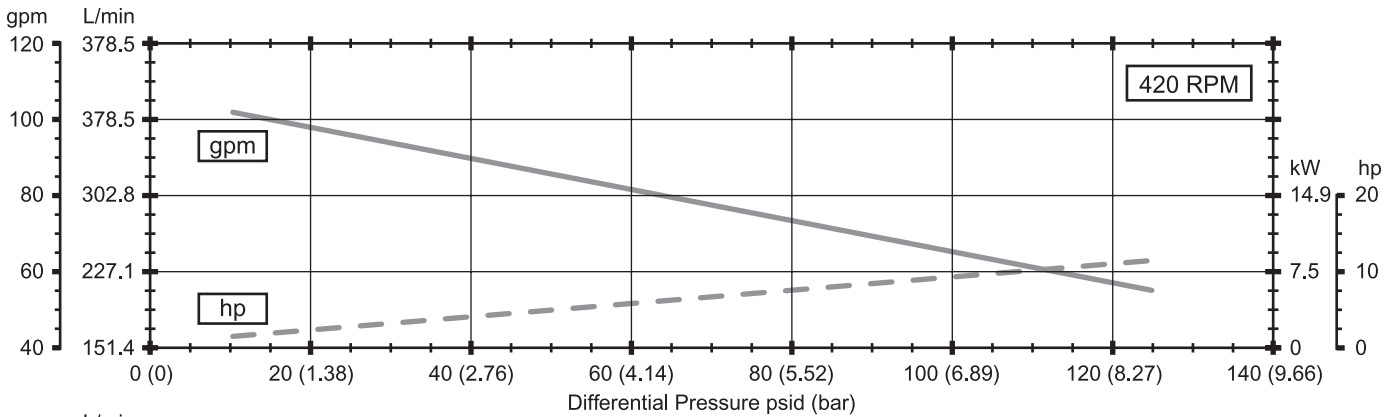

Appendix C—Performance Curves

Z4500

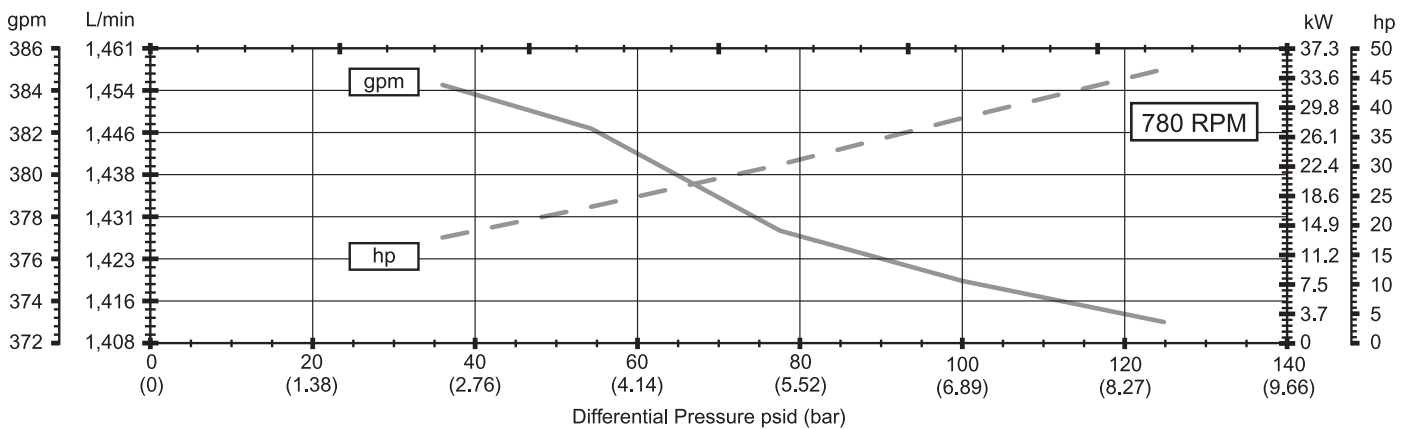
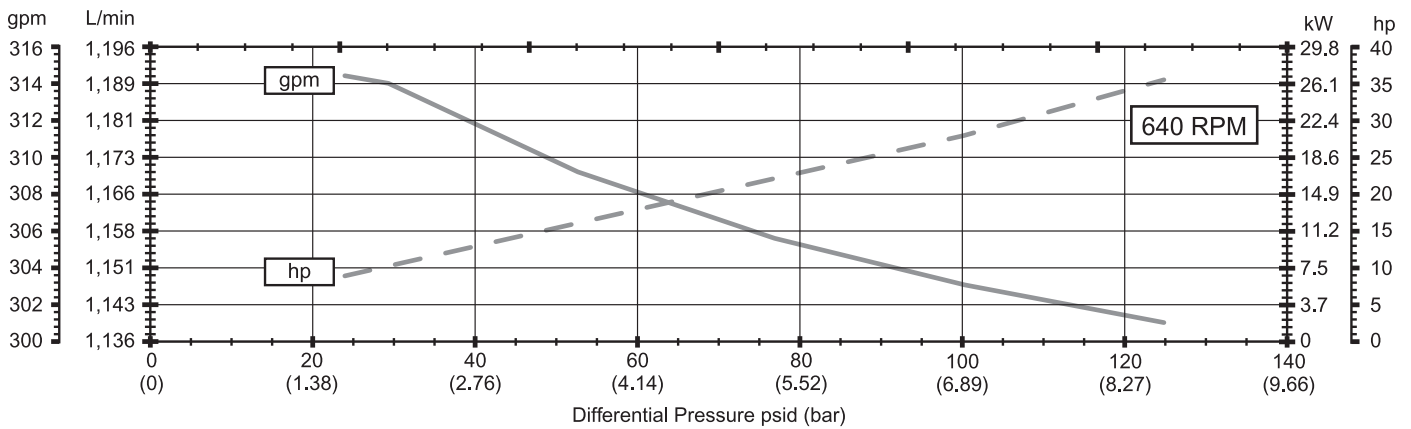
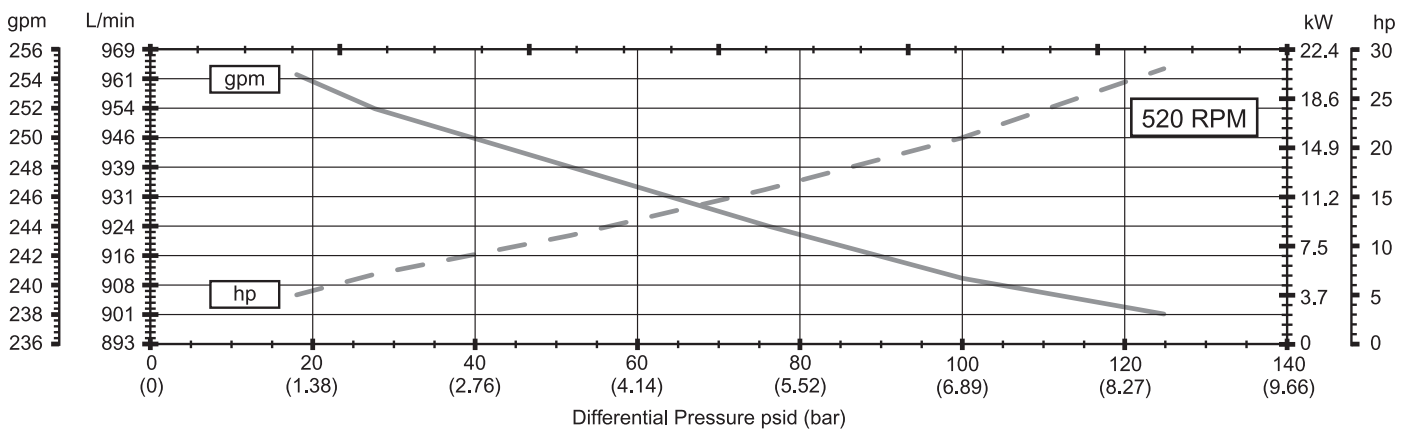
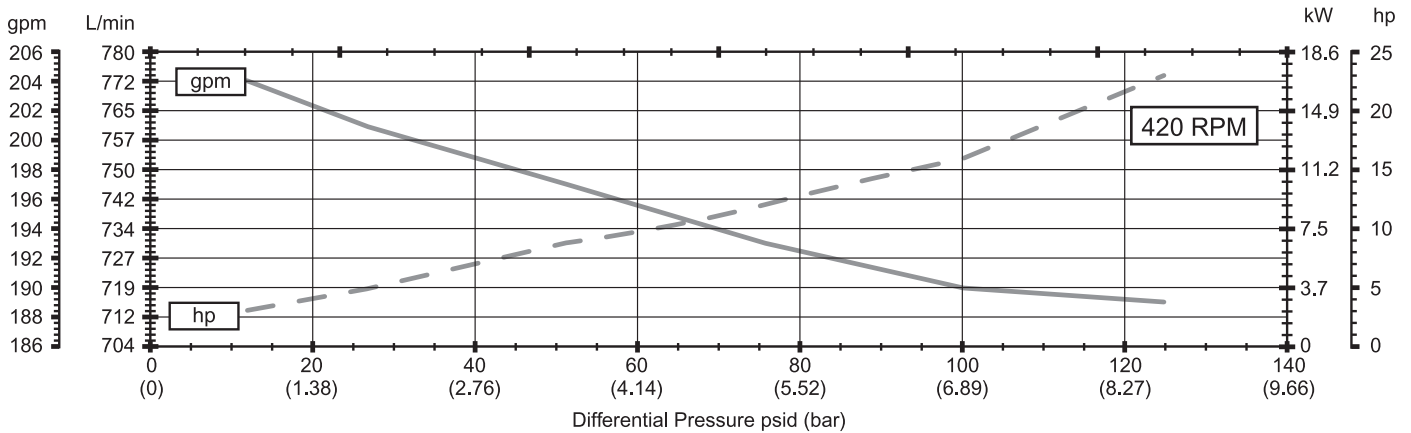

Appendix D—Outline Dimensions for Model Z2000

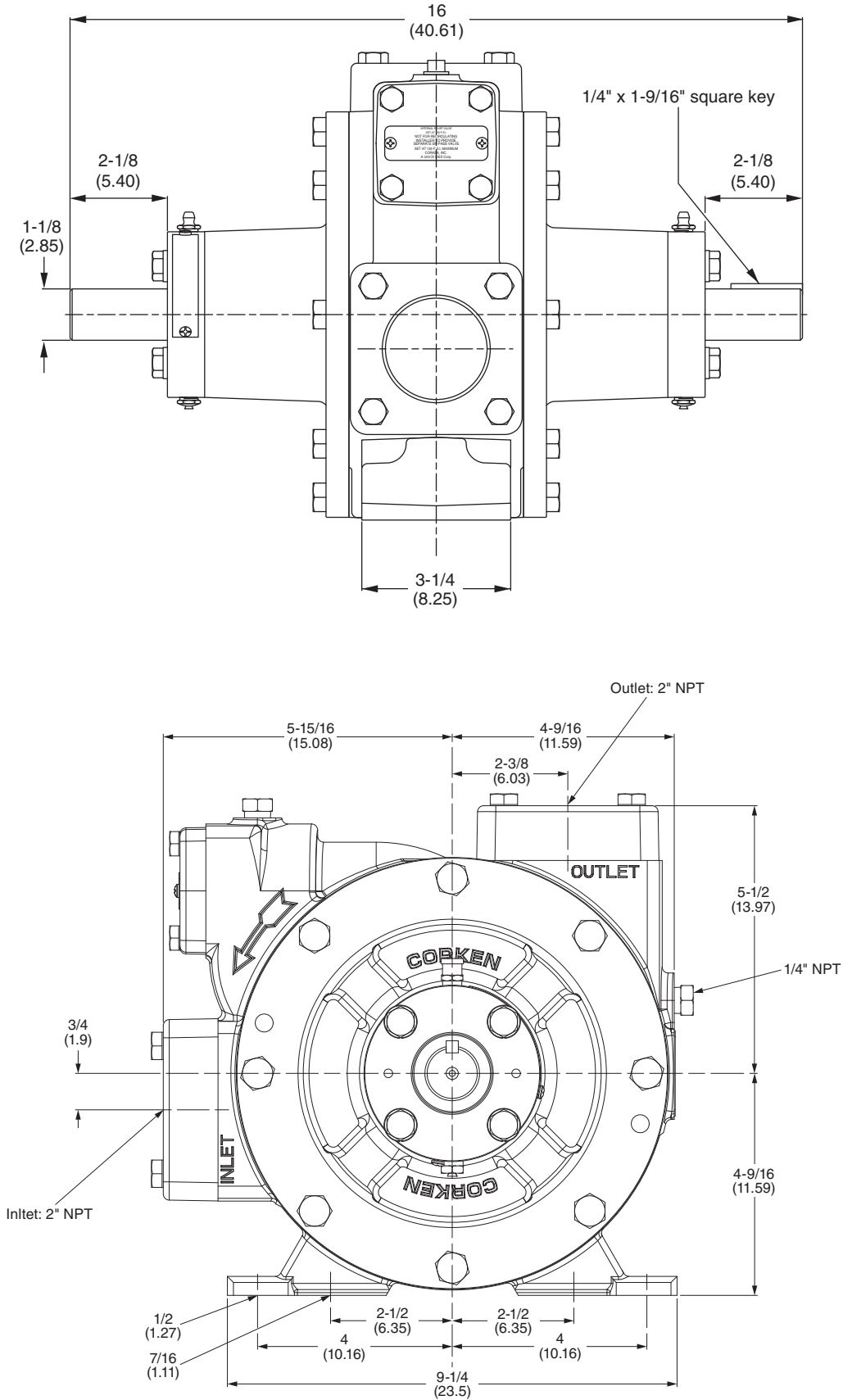

All dimensions are in inches (centimeters).

Appendix D—Outline Dimensions for Model Z3200

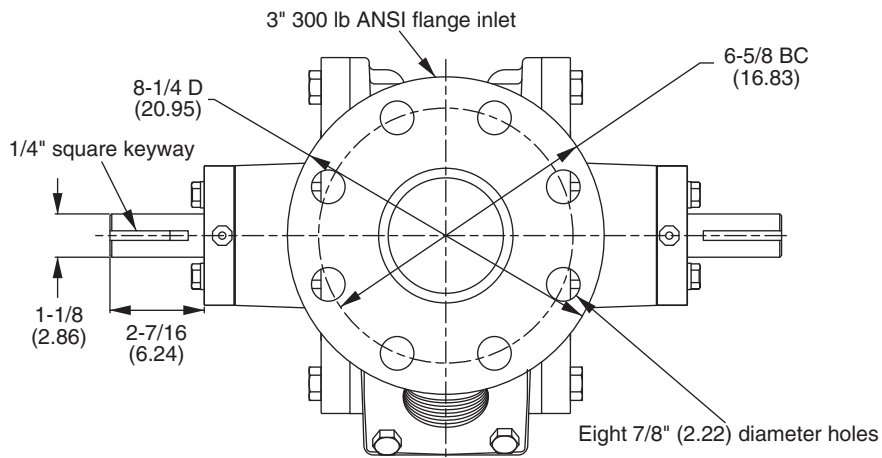
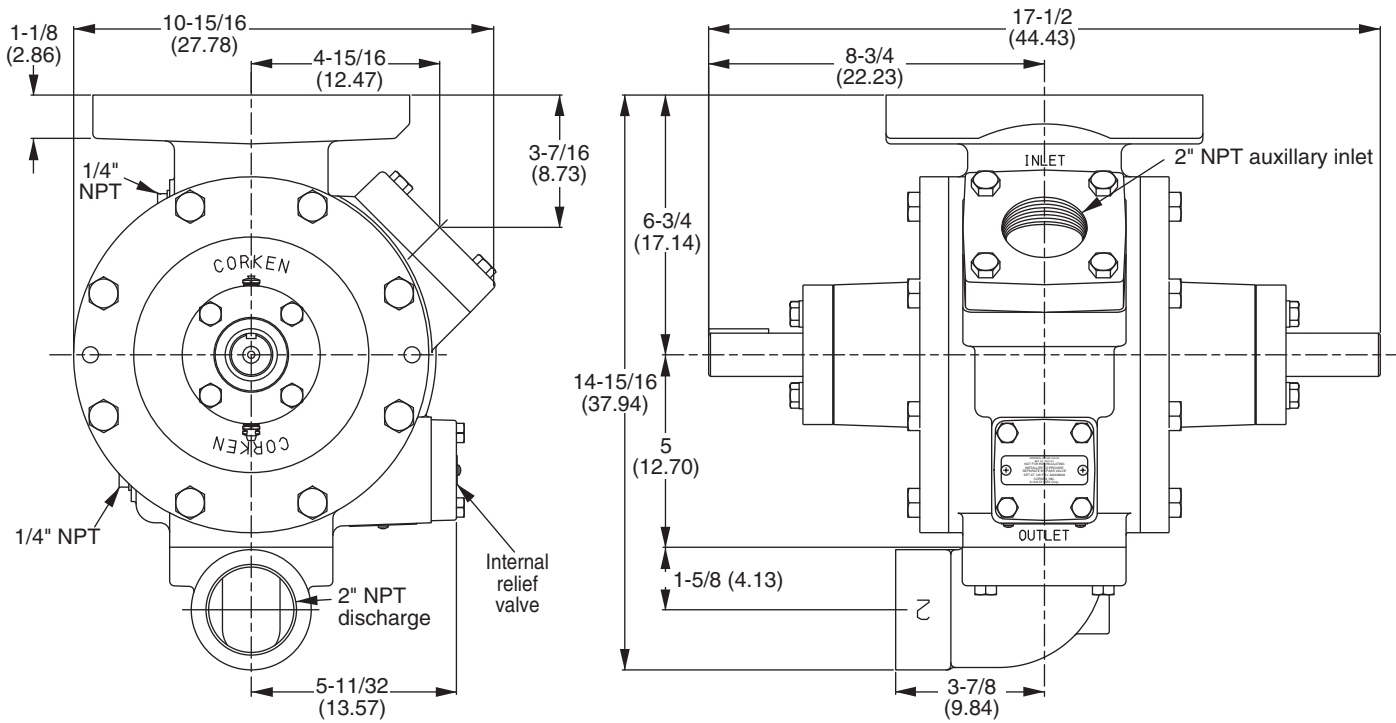

All dimensions are in inches (centimeters).

Appendix D—Outline Dimensions for Model Z3500

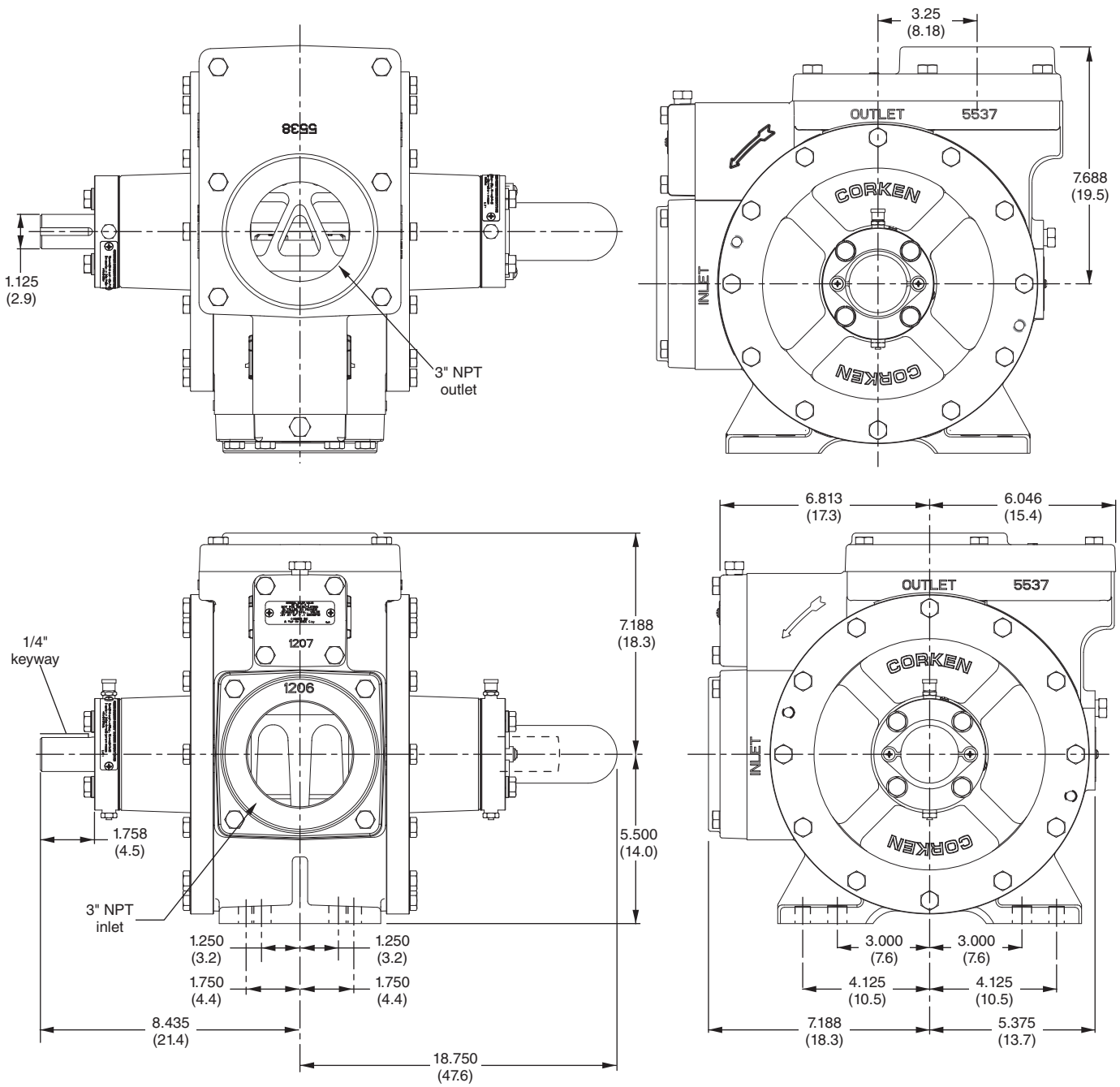

All dimensions are in inches (centimeters).

Appendix D—Outline Dimensions for Model Z4200

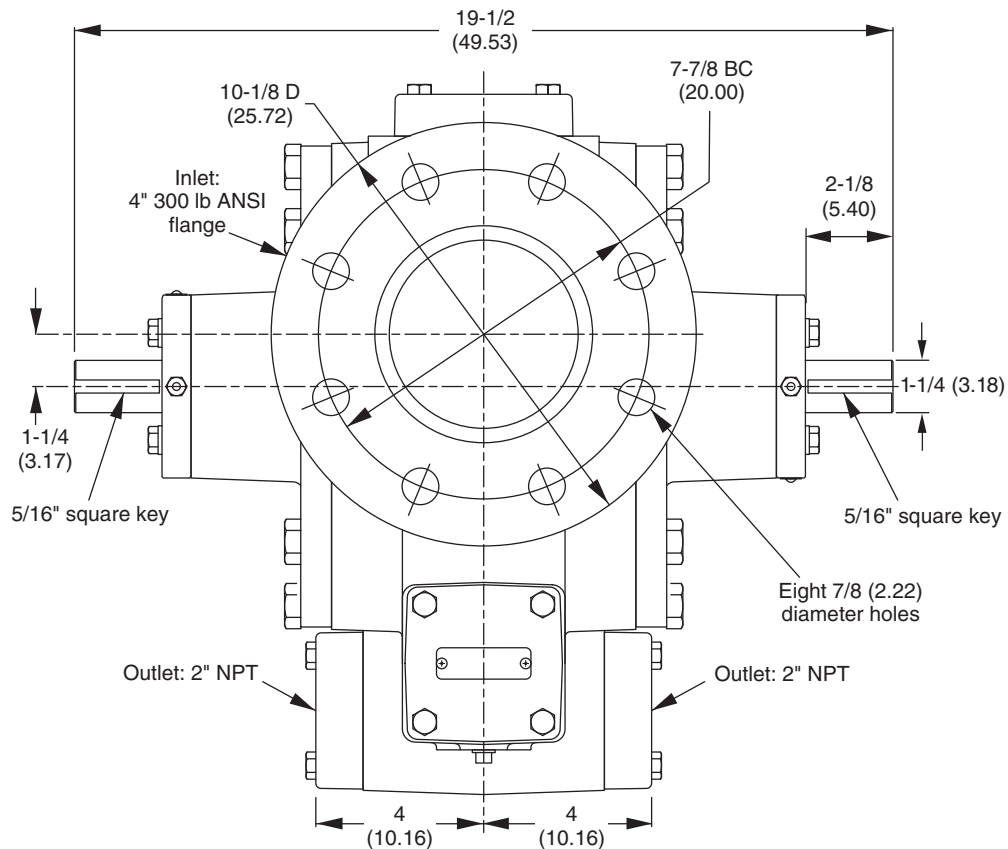
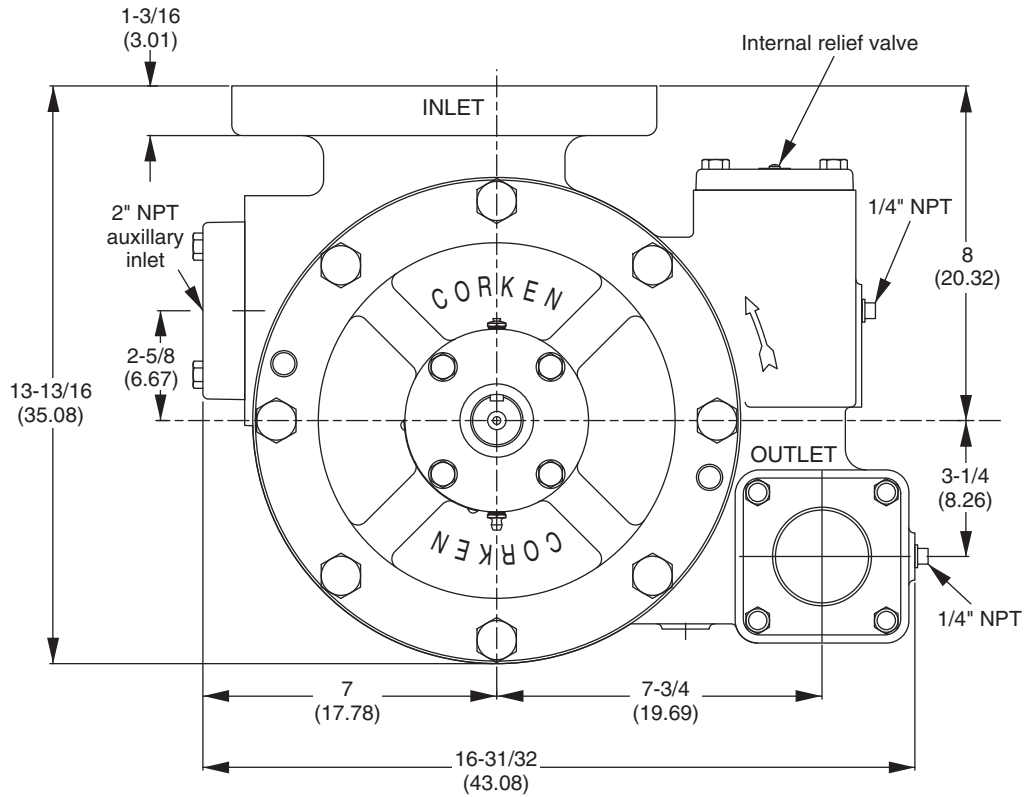

All dimensions are in inches (centimeters).

Appendix D—Outline Dimensions for Model Z4500

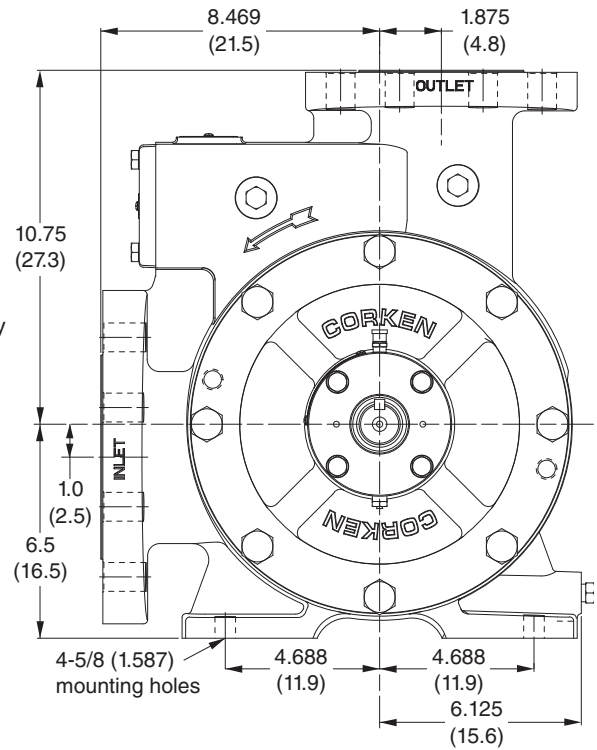
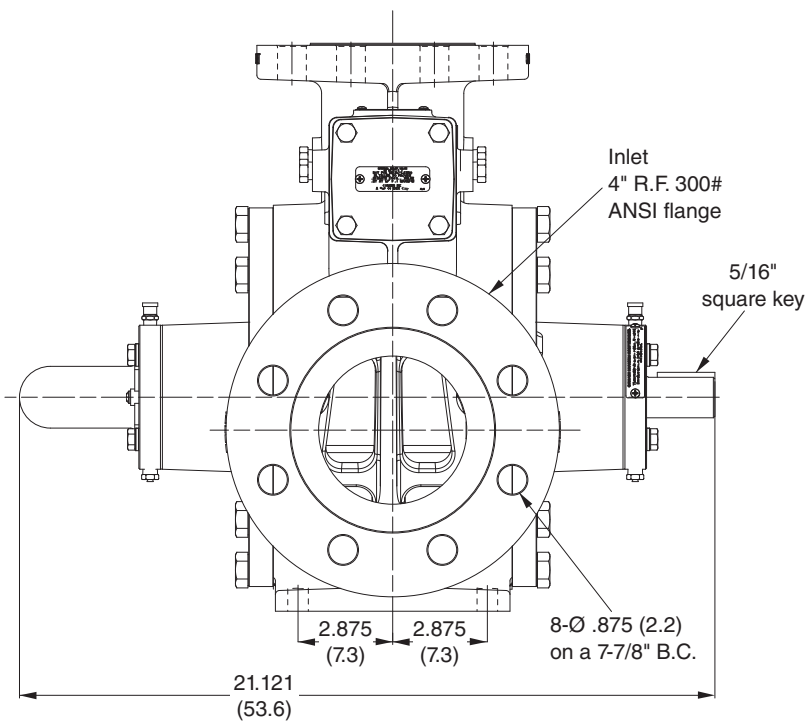
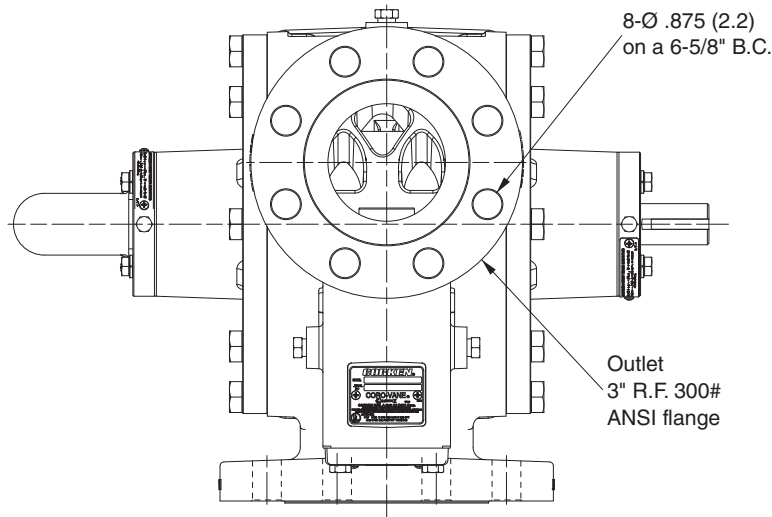

All dimensions are in inches (centimeters).

Appendix D—Outline Dimensions for Model ZH2000

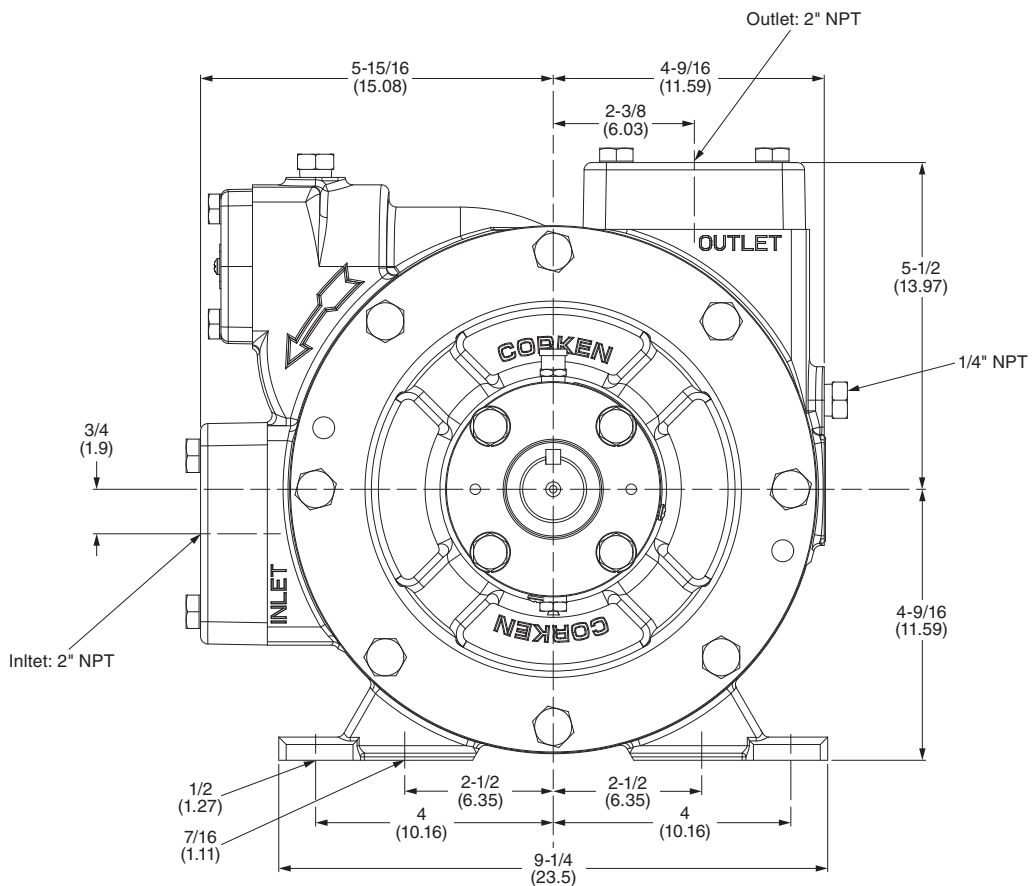
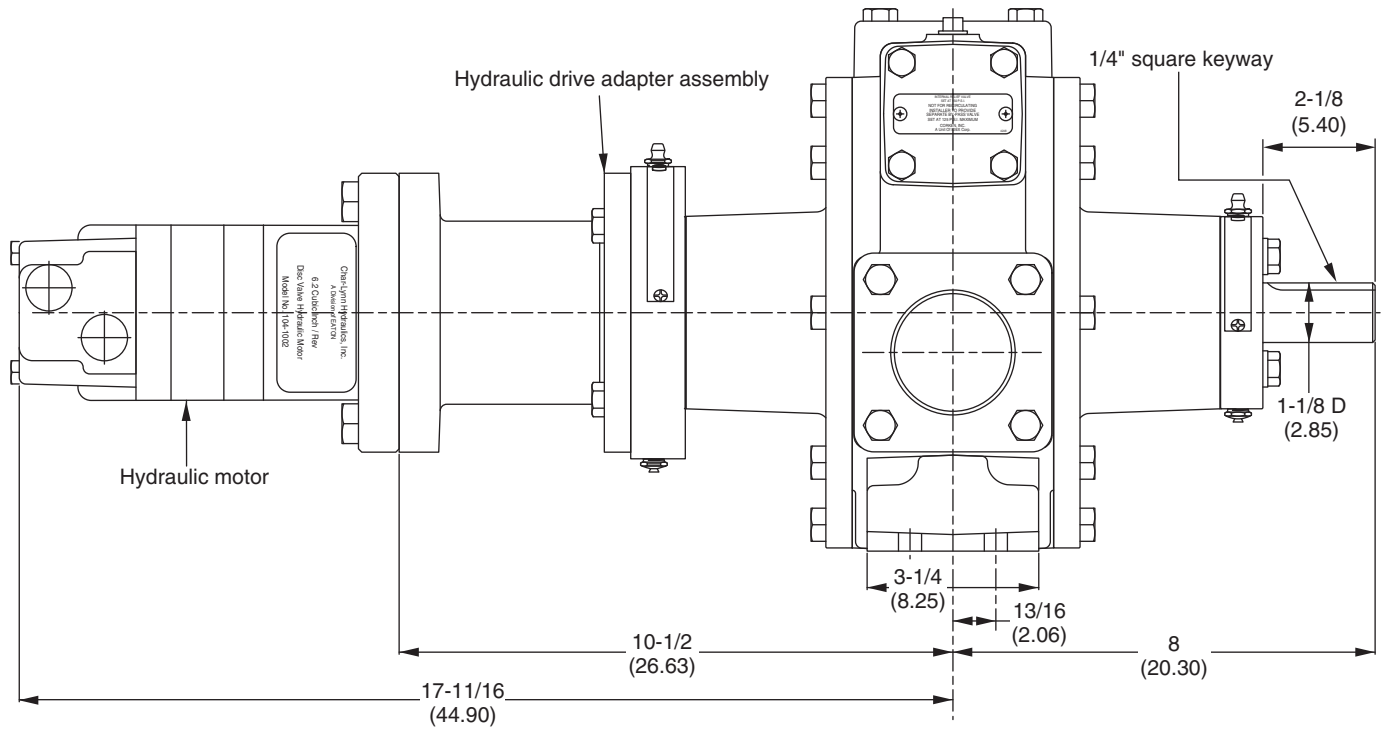

All dimensions are in inches (centimeters).

Appendix D—Outline Dimensions for Model ZH3200

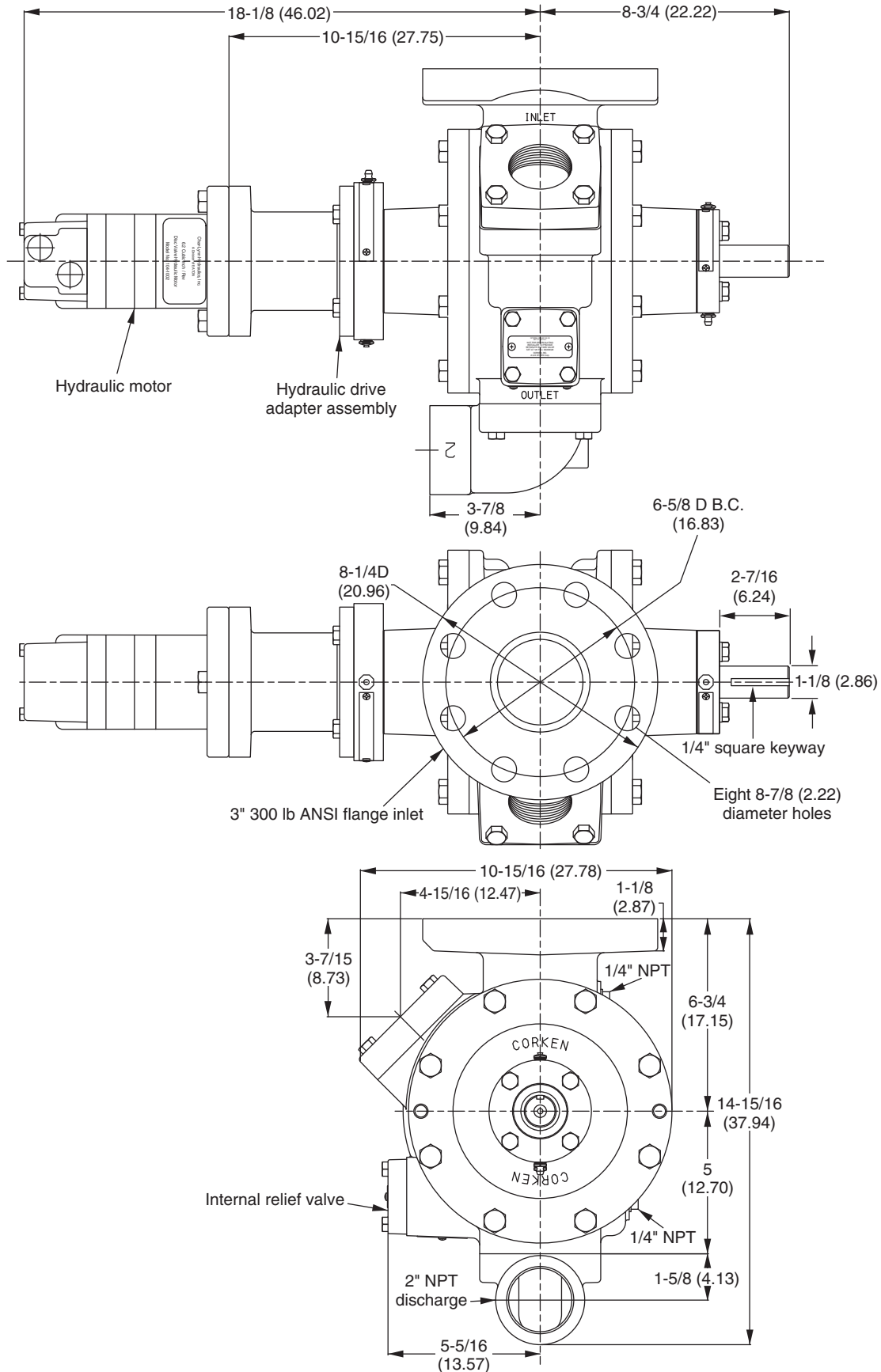

All dimensions are in inches (centimeters).

Appendix D—Outline Dimensions for Model ZH4200

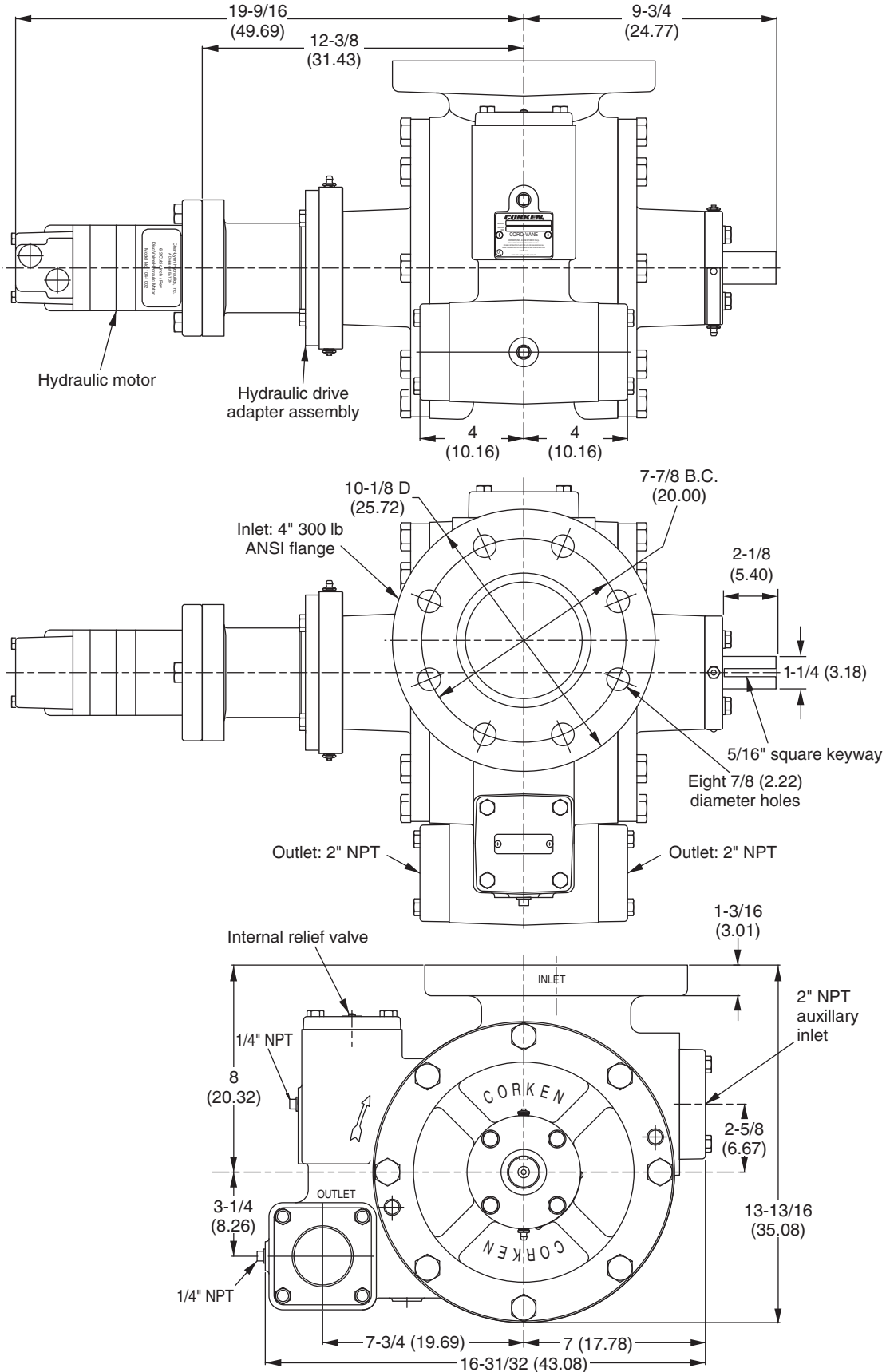

All dimensions are in inches (centimeters).

Appendix D—Outline Dimensions for Z3500–103 Mounting

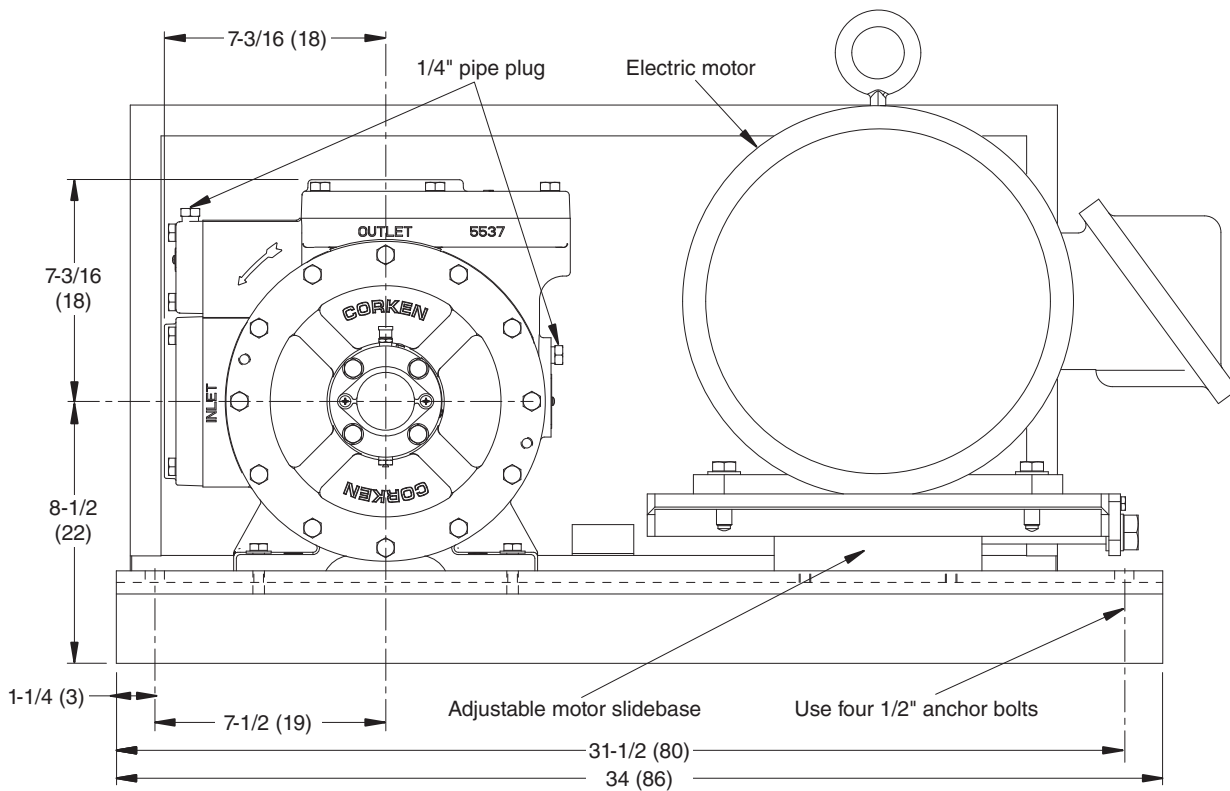
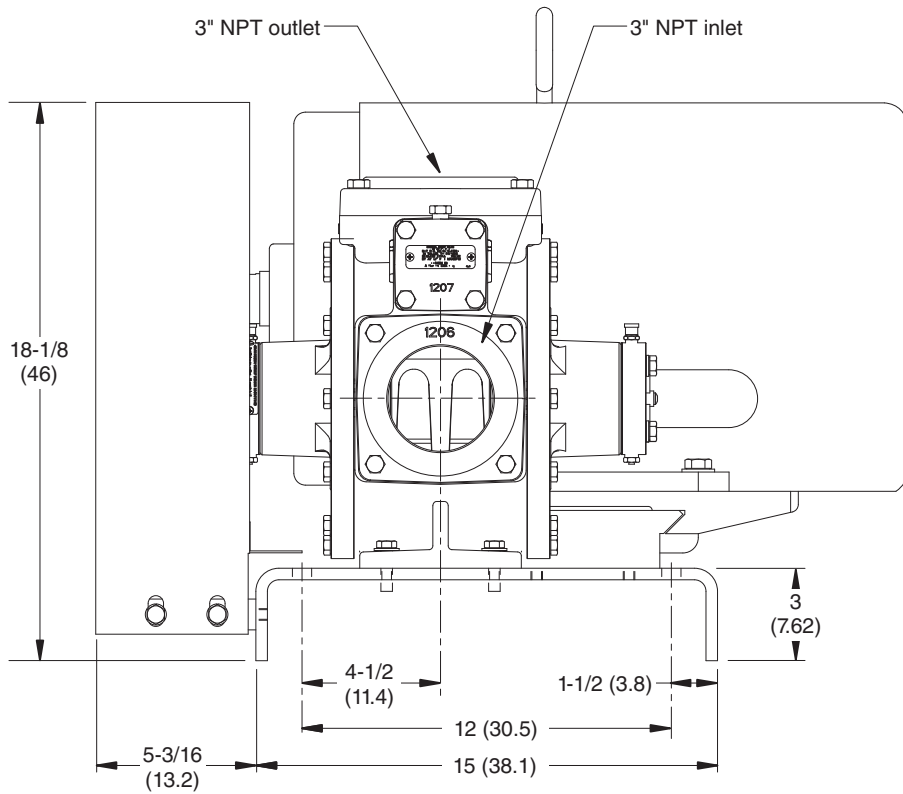

All dimensions are in inches (centimeters).

Appendix D—Outline Dimensions for Z4500–103 Mounting

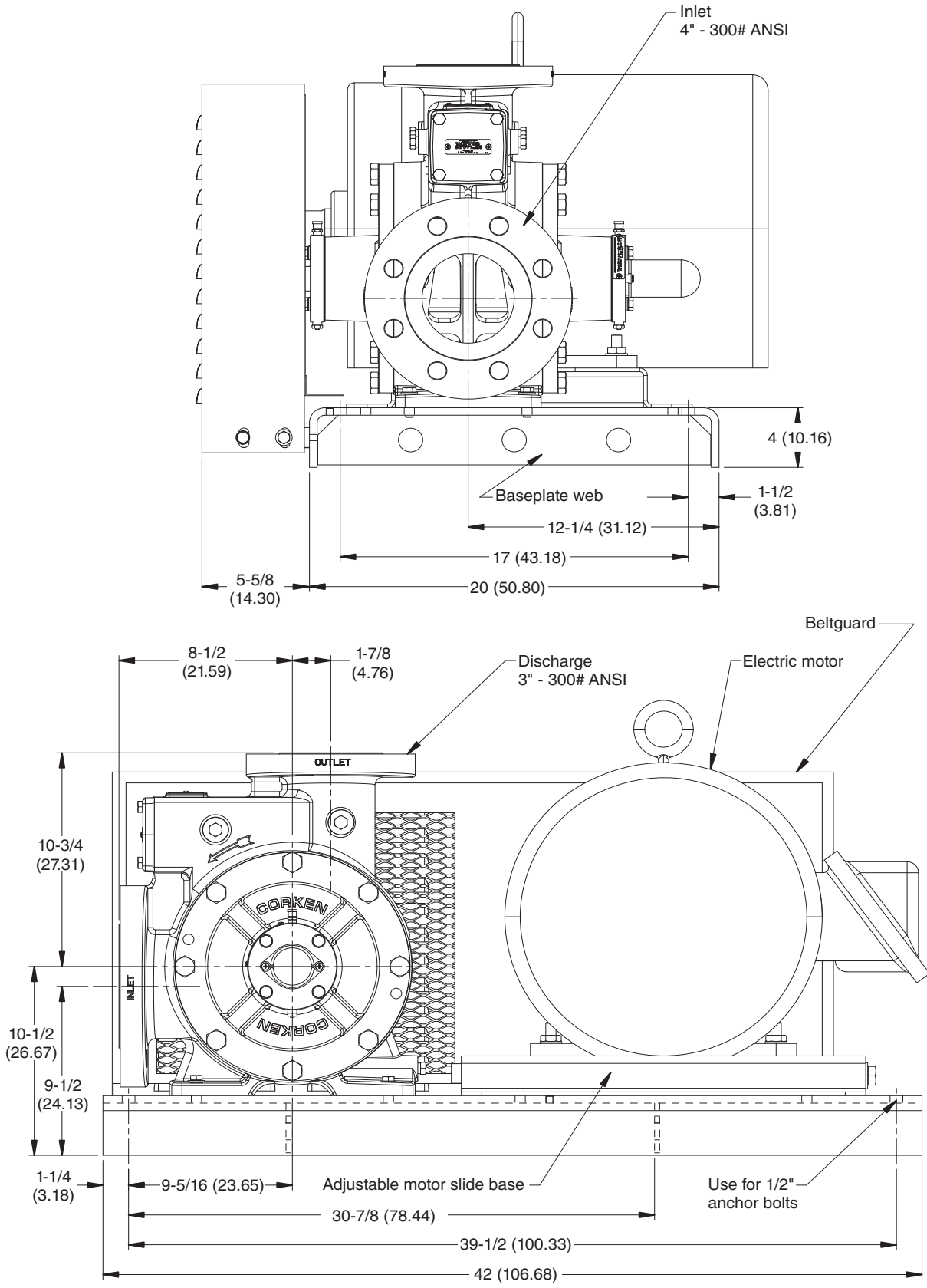

All dimensions are in inches (centimeters).

Appendix E—Parts Details for Models Z/ZH/ZX/ZXH2000

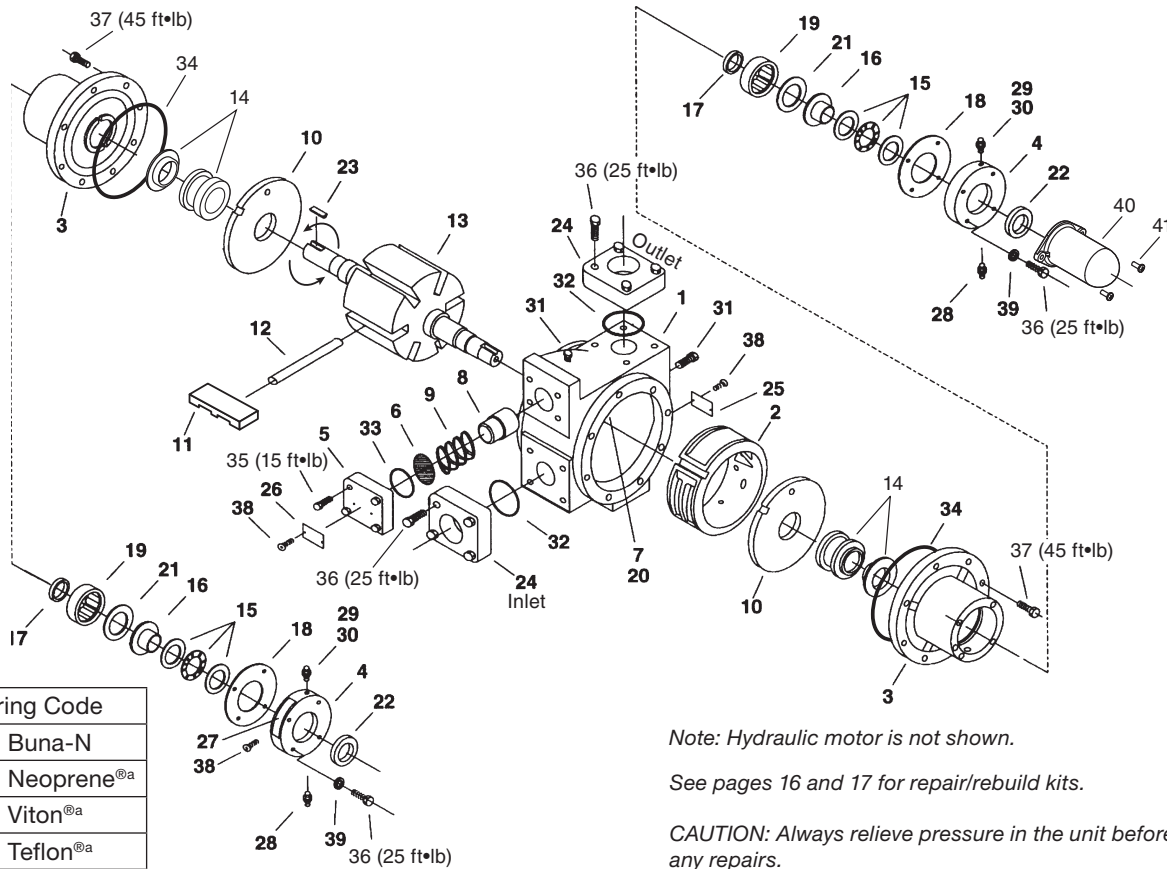

O-ring Code	
A	Buna-N
B	Neoprene ^{®a}
D	Viton ^{®a}
E	Teflon ^{®a}

Note: Hydraulic motor is not shown.

See pages 16 and 17 for repair/rebuild kits.

CAUTION: Always relieve pressure in the unit before attempting any repairs.

Ref. No.	Part No.	Description	Qty
1.	4413	Case	1
2.	4414	Cam	1
3.	4416	Head	2
4.	4417	Bearing cap	2
5.	1174-3	Relief valve cap	1
6.	4282	Shim (Z2000, ZH2000)	1
		Shim (ZX2000, ZXH2000)	3
7.	4424	Cam key	1
8.	4425	Relief valve	1
9.	4426	Relief valve spring (Z2000, ZH2000)	1
	1240	Relief valve spring (ZX2000, ZXH2000)	1
10.	4427	Sideplate	2
11.	4428 ^b	Vane	6
12.	4262-X	Vane driver	3
13.	4430-X2R	Rotor—shaft assembly	1
14.	4431-X_2 ^c	Mech seal assy—cast iron	2
	4431-X_6 ^c	Mech seal assy—silicon carbide	2
15.	4432	Thrust bearing assembly	2
16.	4435	Bearing race mounting ring	2
17.	4438	Grease seal	2
18.	4439	Bearing cap shim (.002) red	As req.
	4439-1	Bearing cap shim (.010) brown	
	4439-2	Bearing cap shim (.020) yellow	
19.	2754-X	Roller bearing	2
20.	3253	Cam key pin	2

Ref. No.	Part No.	Description	Qty
21.	2760-244	Retainer ring	2
22.	4441	Grease seal	2
23.	2270	Shaft key—1/4" x 1-9/16"	2
24.	4479-2	Flange—2" NPT	2
	4479-2S	Flange—2" welded	
25.	2649	Nameplate	1
26.	4248	Relief valve nameplate (Z2000, ZH2000)	1
	4248-1	Relief valve nameplate (ZX2000, ZXH2000)	1
27.	1359	Lubrication instruction plate	2
28.	1343	1/8" NPT relief fitting	2
29.	2158	1/8" NPT grease zerk	2
30.	2159	Lubricap	2
31.	3442	1/4" NPT pipe plug	2
32.	2-231_ ^c	O-ring—flange	2
33.	2-224_ ^c	O-ring—relief valve cap	1
34.	2-261_ ^c	O-ring—case	2
35.	7001-031-NC125A	Bolt—hexagon head	4
36.	7001-037-NC150A	Bolt—hexagon head	16
37.	7001-043-NC125A	Bolt—hexagon head	16
38.	7012-006-SF025E	Screw	8
39.	7206-037A	Lockwasher	8
40.	4985	Shaft protector	1
41.	7012-010SF050E	Screw	2

^aRegistered trademark of the DuPont company.

^bSlots in vanes must face TOWARDS the direction of rotation.

^c_ denotes O-ring code. See chart above.

Appendix E—Parts Details for Models Z/ZH3200

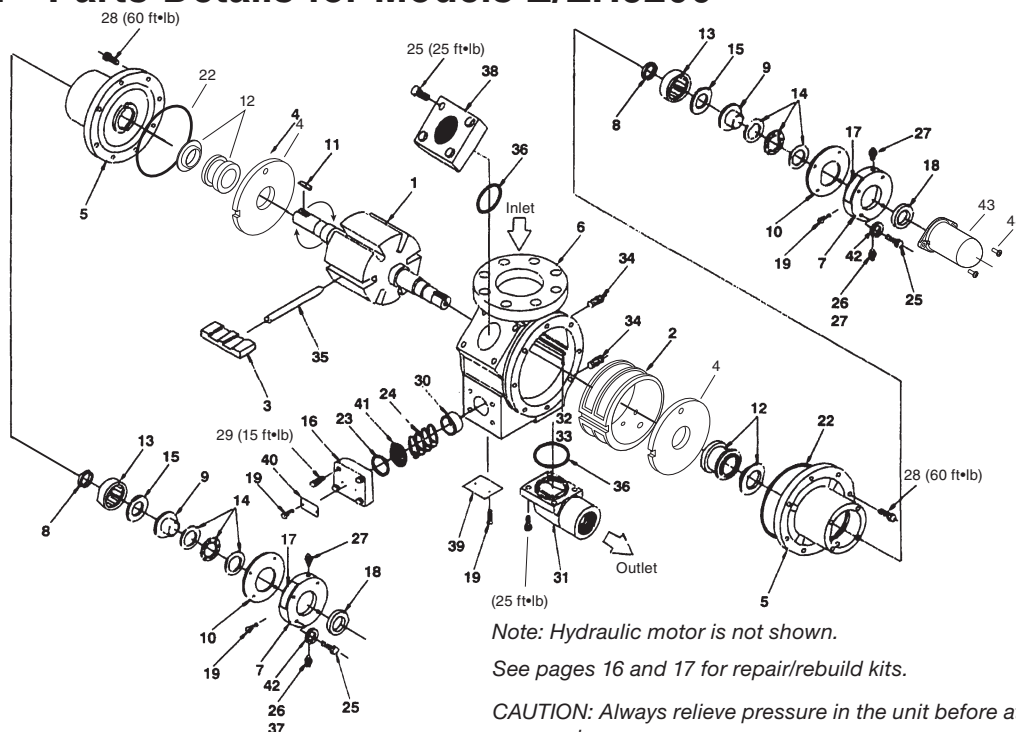

O-ring Code	
A	Buna-N
B	Neoprene ^{®a}
D	Viton ^{®a}
E	Teflon ^{®a}

Note: Hydraulic motor is not shown.

See pages 16 and 17 for repair/rebuild kits.

CAUTION: Always relieve pressure in the unit before attempting any repairs.

Ref. No.	Part No.	Description	Qty
1.	4495-X2R	Rotor shaft assembly	1
2.	4242	Cam	1
3.	4232 ^c	Vane	6
4.	4231	Sideplate	2
5.	4488	Head	2
6.	4239	Case	1
7.	4417	Bearing cap	2
8.	4438	Grease seal	2
9.	4435	Mounting ring	2
10.	4439	Bearing shim (.002) red	As req.
	4439-1	Bearing shim (.010) brown	
	4439-2	Bearing shim (.020) yellow	
11.	2270	Shaft key	2
12.	4431-X_2 ^b	Mechanical seal assembly—cast iron	2
	4431-X_6 ^b	Mechanical seal assembly—silicon carbide	2
13.	2754	Bearing outer race	2
14.	4432	Thrust bearing assembly	2
15.	2760-244	Retainer ring	2
16.	1174-2	Relief valve cap	1
17.	1359	Lubrication instruction plate	2
18.	4441	Grease seal	2
19.	7012-006SF019E	Screw	8
20.	—	Not shown	—
21.	—	Not shown	—
22.	2-262_ ^b	O-ring—case	2
23.	2-224_ ^b	O-ring—relief valve cap	1
24.	1240	Relief valve spring	1

Ref. No.	Part No.	Description	Qty
25.	7001-037NC150A	Bolt—3/8-16 x 1-1/2" hex head	16
26.	2158	1/8" NPT grease zerk	2
27.	1343	1/8" NPT relief fitting	2
28.	7001-050NC150A	Bolt—1/2-13 x 1-1/2" hex head	16
29.	7001-031NC125A	Bolt—5/16-16 x 1-1/4" hex head	4
30.	1241	Relief valve	1
31.	1172-1.5	Outlet flange—1.5" NPT	1
	1172-1.5S	Outlet flange—1.5" WF	1
	1172-2	Outlet flange—2" NPT	1
	1172-2S	Outlet flange—2" WF	1
	1947	Outlet flange—1.5" NPT ell	1
	4243	Outlet flange—2" NPT ell	1
32.	4241	Cam key	1
	3253	Cam key pin	1
34.	3442	1/4" NPT pipe plug	1
35.	4262-X	Vane driver	3
36.	2-234_ ^b	O-ring—flange	1
37.	2159	Lubricap	2
38.	1172-1.5	Aux. inlet flange—1.5" NPT	1
	1172-15S	Aux. inlet flange—1.5" WF	1
	1172-2	Aux. inlet flange—2" NPT	1
	1172-2S	Aux. inlet flange—2" WF	1
	1920-3	Aux. inlet flange—blind	1
	4243	Aux. inlet flange—2" NPT ell	1
39.	2649	Nameplate	1
40.	4248	Relief valve nameplate	1
41.	4282	Relief valve shim	As req.
42.	7206-037A	3/8" lockwasher	8
43.	4985	Shaft protector	1
44.	7012-010SF050E	Screw	2

^aRegistered trademark of the DuPont company.

^b_ denotes O-ring code. See chart above.

^cSlots in vanes must face TOWARDS the direction of rotation

Appendix E—Parts Details for Models Z3500

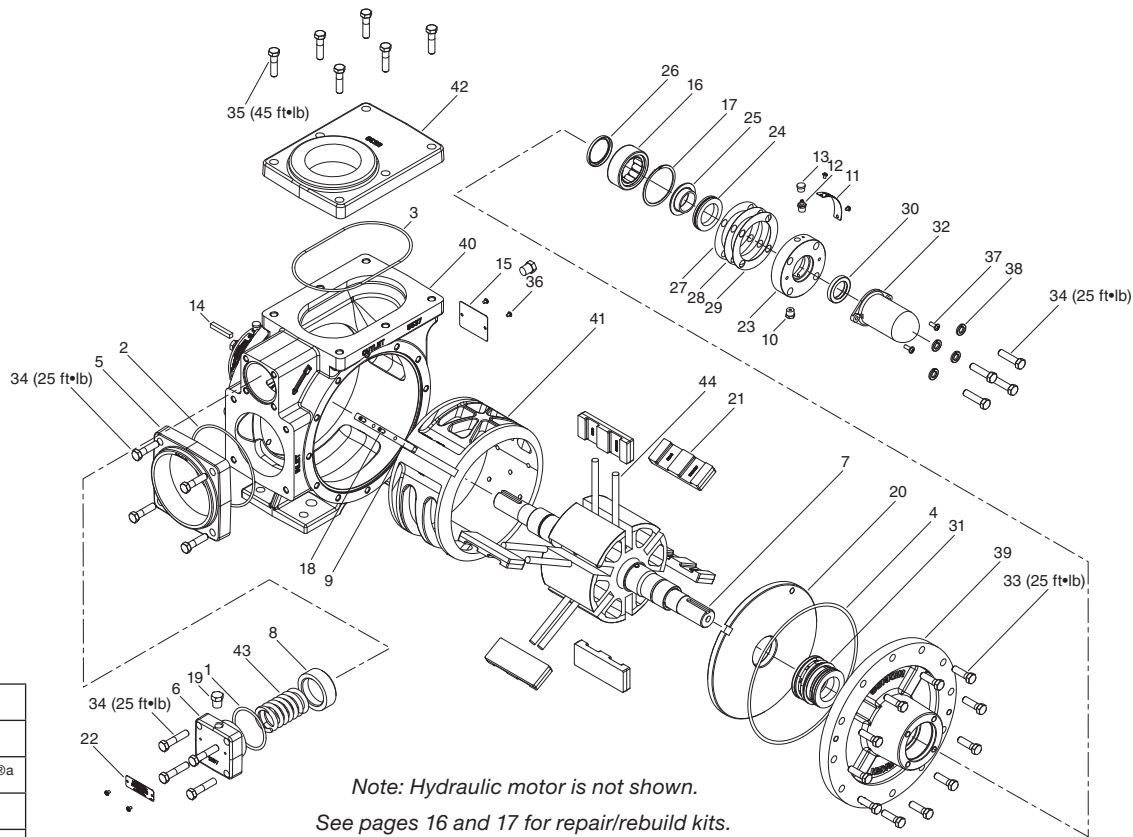

O-ring Code	
A	Buna-N
B	Neoprene ^{®a}
D	Viton ^{®a}
E	Teflon ^{®a}

Note: Hydraulic motor is not shown.
See pages 16 and 17 for repair/rebuild kits.

CAUTION: Always relieve pressure in the unit before attempting any repairs.

Ref. No.	Part No.	Description	Qty
1.	2-228 ^b	O-ring	1
2.	2-245 ^b	O-ring	1
3.	2-259 ^b	O-ring	1
4.	2-268 ^b	O-ring	2
5.	1206-3	Inlet flange—3" NPT	1
	1206-4	Inlet flange—4" NPT	1
	1206-3S	Inlet flange—3" WF	1
	1206-4S	Inlet flange—4" WF	1
6.	1207-2	Relief valve cap	1
7.	1208-1X6R	Rotor shaft assembly	1
8.	1224	Relief valve	1
9.	1309	Cam key	1
10.	1343	Grease relief fitting	2
11.	1359	Lubrication plate	2
12.	2158	Grease zerk	2
13.	2159	Lubricap	2
14.	2270	Shaft key—1/4"	1
15.	2649	Nameplate	1
16.	2754-X	Roller bearing	2
17.	2760-244	Retainer ring	2
18.	3253	Cam key pin	2
19.	3442	Pipe plug—1/4" NPT	2
20.	3935	Sideplate	2
21.	3936 ^c	Vane	6
22.	4248	Relief valve warning tag	1

Ref. No.	Part No.	Description	Qty
23.	4417	Bearing cap	2
24.	4432	Thrust bearing assembly	2
25.	4435	Thrust bearing mounting ring	2
26.	4438	Grease seal / Oil seal	2
27.	4439	Bearing cap shim—0.002"	2
28.	4439-1	Bearing cap shim—0.010"	2
29.	4439-2	Bearing cap shim—0.020"	2
30.	4441	Grease seal	2
31.	6660-X_2 ^b	Mechanical seal assembly—cast iron	2
	6660-X_6 ^b	Mechanical seal assembly—silicon carbide	2
32.	4985	Shaft protector	1
33.	7001-037NC125A	Hex head bolt	24
34.	7001-037NC150A	Hex head bolt	16
35.	7001-043NC150A	Hex head bolt	6
36.	7012-006SF019E	Screw	9
37.	7012-010SF050E	Screw	2
38.	7206-037A	Lock washer—0.375"	8
39.	5534	Head	2
40.	5537	Case	1
41.	5539	Cam	1
42.	5538	Outlet flange—3" NPT Elongated	1
	5538-3S	Outlet flange—3" WF Elongated	1
43.	5548	Spring	1
44.	5554-X	Vane driver	6

^aRegistered trademarks of the DuPont company.

^b _ denotes O-ring code. See chart above.

^cSlots in vanes must face TOWARDS the direction of rotation

Appendix E—Parts Details for Models Z/ZH4200

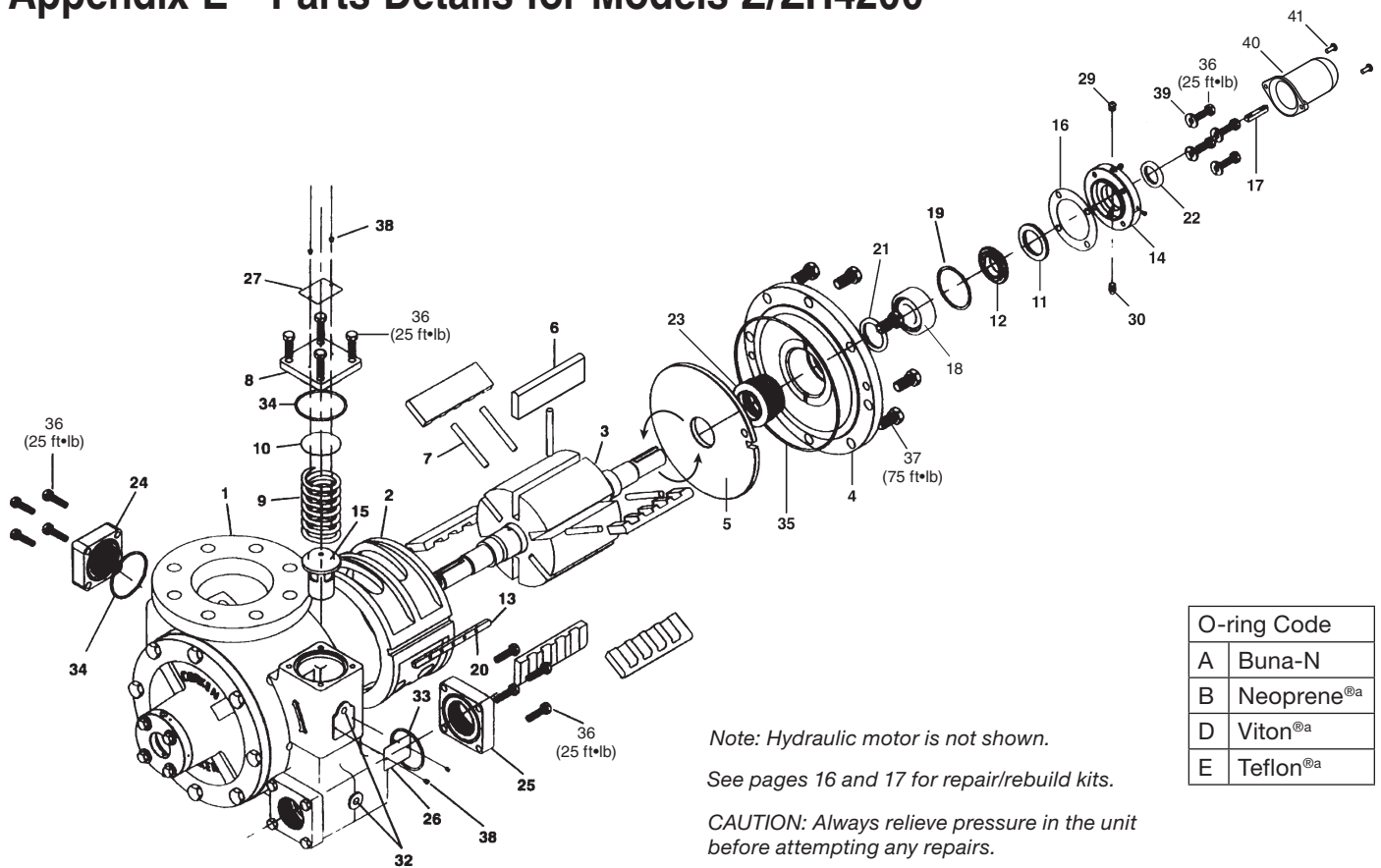

Ref. No.	Part No.	Description	Qty
1.	4442 ^b	Case	1
2.	4443 ^b	Cam	1
3.	4444-X2R ^b	Rotor-shaft assembly	1
4.	4445 ^b	Head	2
5.	4446	Sideplate	2
6.	4448 ^c	Vane	6
7.	4449-X	Vane driver	5
8.	4450	Relief valve cap	1
9.	4451	Relief valve spring	1
10.	4452	Shim	1
11.	4453	Thrust bearing assembly	2
12.	4454	Bearing race mounting ring	2
13.	4455	Cam key	1
14.	4456	Bearing cap	2
15.	4457	Relief valve	1
16.	4458	Bearing cap shim (.002) red	As req.
	4458-1	Bearing cap shim (.010) brown	
	4458-2	Bearing cap shim (.020) yellow	
17.	4459	Shaft key—5/16 x 1-3/4	1
18.	4460-X	Roller bearing	2
19.	2760-283	Retainer ring	2
20.	3253	Cam key pin	5
21.	4462	Grease seal	2

Ref. No.	Part No.	Description	Qty
22.	4463	Grease seal	2
23.	4464-X_2 ^b	Mechanical seal assembly—cast iron	2
	4464-X_6 ^b	Mechanical seal assembly—silicon carbide	2
24.	1172-2	Aux. inlet flange—2" NPT	1
	1172-2S	Aux. inlet flange—2" WF	1
	1920-3	Aux. inlet flange—blind	1
25.	4479-2 ^d	Discharge flange—2" NPT	2
	4981-2	Discharge flange—2" NPT	2
26.	2649	Nameplate	1
27.	4248	Relief valve nameplate	1
28.	1359	Lubrication instruction plate	2
29.	1343	1/8 NPT relief fitting	2
30.	2158	1/8 NPT grease zerk	2
31.	2159 ^b	Lubricap	2
32.	3442	1/4 NPT pipe plug	2
33.	2-231_ ^b	O-ring—discharge flange	2
34.	2-234_ ^b	O-ring—auxiliary inlet flange	1
35.	2-270_ ^b	O-ring—case	2
36.	7001-037NC150A	Bolt—hexagon head	24
37.	7001-062NC125A	Bolt—hexagon head	16
38.	7012-006SF019E	Screw	8
39.	7206-037A	Lockwasher	8
40.	4985	Shaft protector	1
41.	7012-010SF050E	Screw	2

^aRegistered trademark of the DuPont company.

^b _ denotes O-ring code. See chart above.

^cSlots in vanes must face TOWARDS the direction of rotation

^dPrior to January 1998.

Appendix E—Parts Details for Model Z4500

O-ring Code	
A	Buna-N
B	Neoprene ^{®a}
D	Viton ^{®a}
E	Teflon ^{®a}

Note: Hydraulic motor is not shown.

See pages 16 and 17 for repair/rebuild kits.

CAUTION: Always relieve pressure in the unit before attempting any repairs.

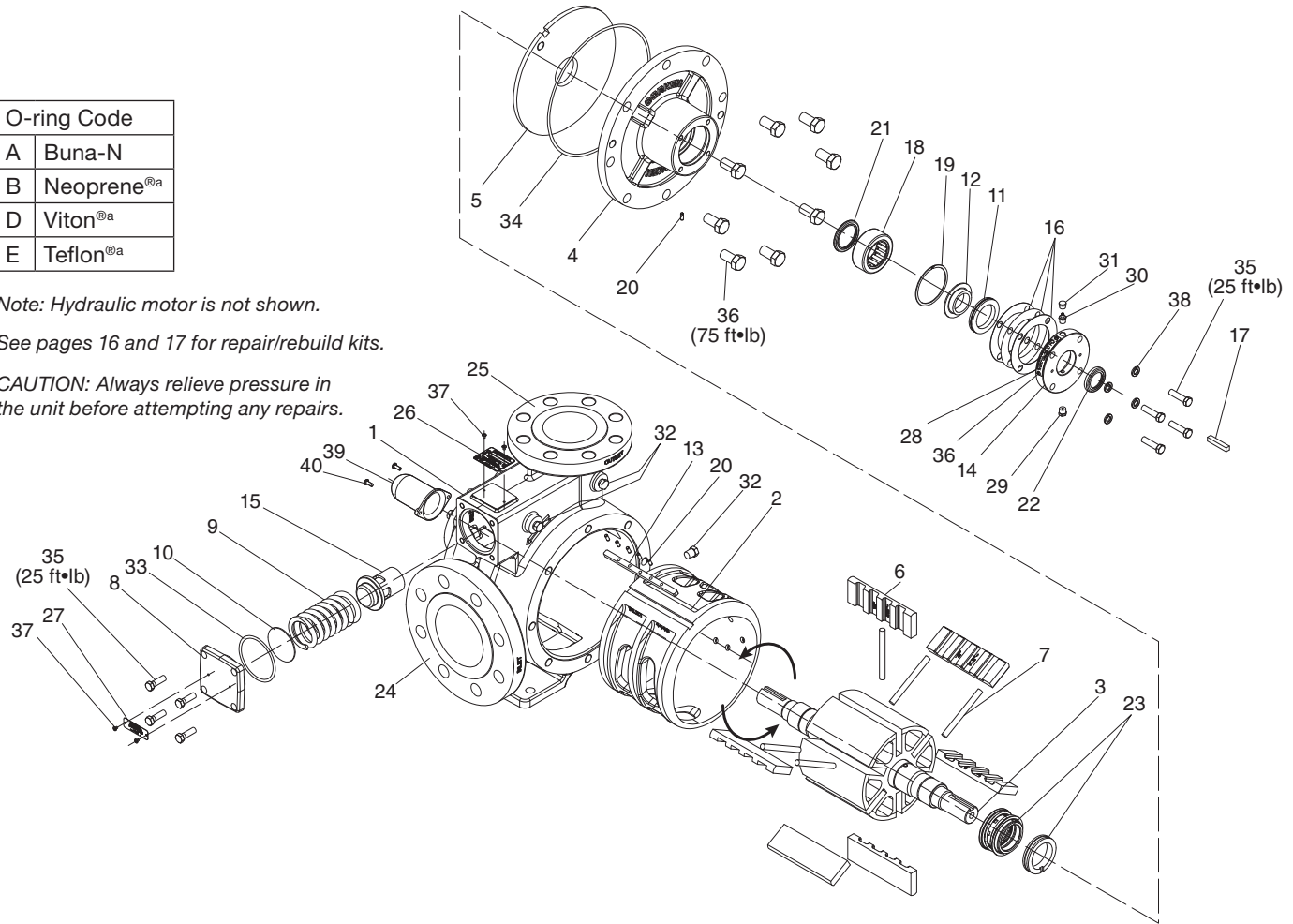

Ref. No.	Part No.	Description	Qty
1.	5522	Case	1
2.	4443	Cam	1
3.	4444-X2R	Rotor-shaft assembly	1
4.	4445	Head	2
5.	4446	Sideplate	2
6.	4448 ^c	Vane	6
7.	4449-X	Vane driver	5
8.	4450	Relief valve cap	1
9.	4451	Relief valve spring	1
10.	4452	Shim	1
11.	4453	Thrust bearing assembly	2
12.	4454	Bearing race mounting ring	2
13.	4455	Cam key	1
14.	4456	Bearing cap	2
15.	4457	Relief valve	1
16.	4458	Bearing cap shim (.002) red	As req.
	4458-1	Bearing cap shim (.010) brown	
	4458-2	Bearing cap shim (.020) yellow	
17.	4459	Shaft key—5/16 x 1-3/4	1
18.	4460-X	Roller bearing	2
19.	2760-283	Retainer ring	2

Ref. No.	Part No.	Description	Qty
20.	3253	Cam key pin	5
21.	4462	Grease seal	2
22.	4463	Grease seal	2
23.	4464-X_2 ^b	Mechanical seal assembly—cast iron	2
	4464-X_6 ^b	Mechanical seal assembly—silicon carbide	2
24.	---	Inlet flange—4" ANSI	1
25.	---	Outlet flange—3" ANSI	1
26.	2649	Nameplate	1
27.	4248	Relief valve nameplate	1
28.	1359	Lubrication instruction plate	2
29.	1343	1/8 NPT relief fitting	2
30.	2158	1/8 NPT grease zerk	2
31.	2159	Lubricap	2
32.	3442	1/4 NPT pipe plug	2
33.	2-234_ ^b	O-ring—relief valve	1
34.	2-270_ ^b	O-ring—case	2
35.	7001-037NC150A	Bolt—hexagon head	16
36.	7001-062NC125A	Bolt—hexagon head	16
37.	7012-006SF019E	Screw	8
38.	7206-037A	Lockwasher	8
39.	4985	Shaft cover	1
40.	7012-010SF050E	Screw	2

^aRegistered trademark of the DuPont company.

^b _ denotes O-ring code. See chart above.

^cSlots in vanes must face TOWARDS the direction of rotation

Appendix E—Parts Details for Hydraulic Adapter (4496-X1)

Fits Models Z2000, Z3200, and Z3500 Only

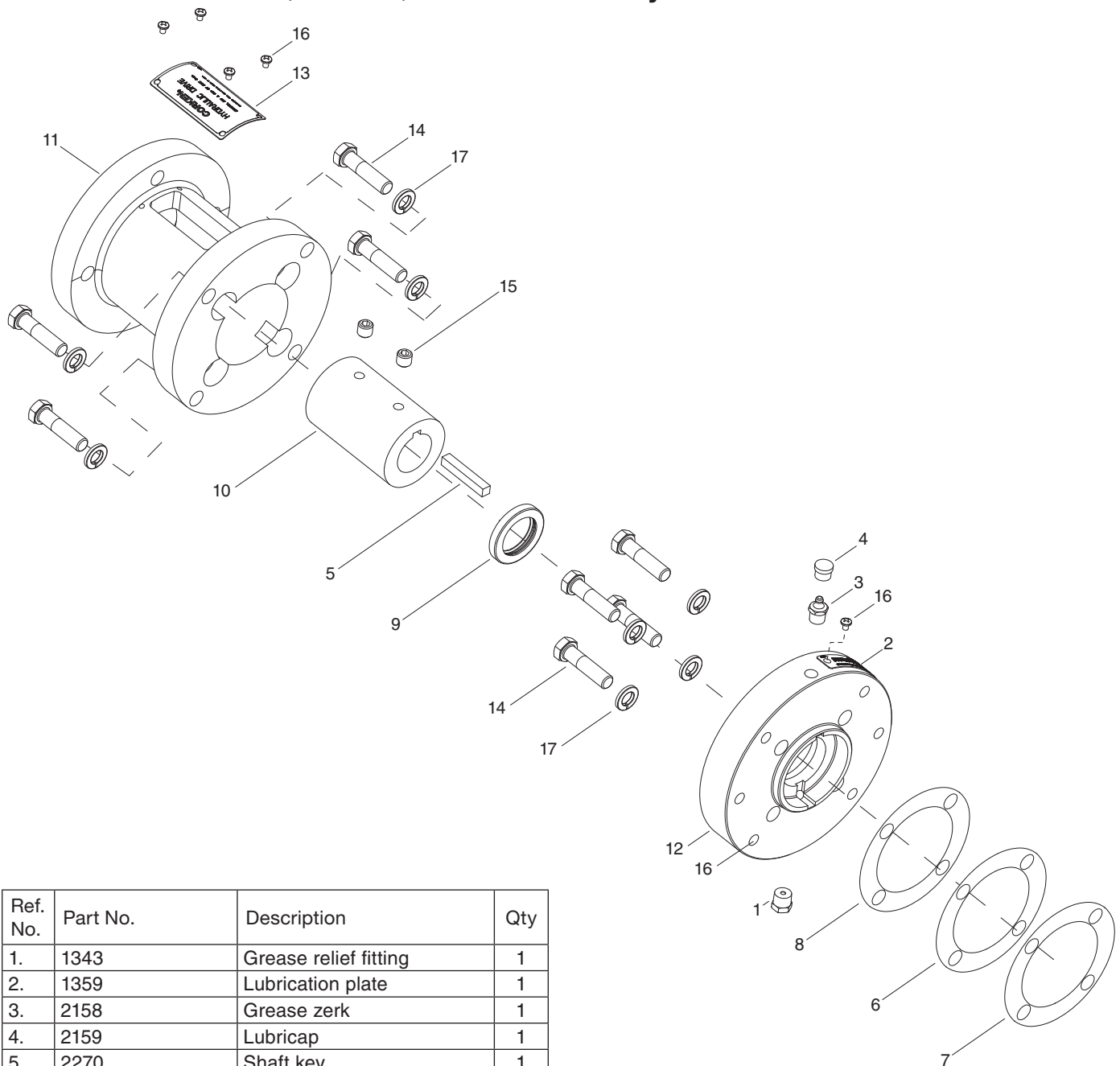

Ref. No.	Part No.	Description	Qty
1.	1343	Grease relief fitting	1
2.	1359	Lubrication plate	1
3.	2158	Grease zerk	1
4.	2159	Lubricap	1
5.	2270	Shaft key	1
6.	4439	Bearing cap shim—0.002"	1
7.	4439-1	Bearing cap shim—0.010"	1
8.	4439-2	Bearing cap shim—0.020"	1
9.	4441	Grease seal	1
10.	4487-1	Hydraulic drive solid coupling	1
11.	4496	Hydraulic drive bracket	1
12.	4497	Hydraulic drive bearing cap	1
13.	4499	Hydraulic drive name plate	1
14.	7001-037NC150A	Bolt—hexagon head	8
15.	7006-037NC037A	Set screw	2
16.	7012-006SF019E	Screw	6
17.	7206-037A	Lock washer—0.375"	8

Appendix E—Parts Details for Hydraulic Adapter (4496-1X1)

Fits Models Z4200 and Z4500 Only

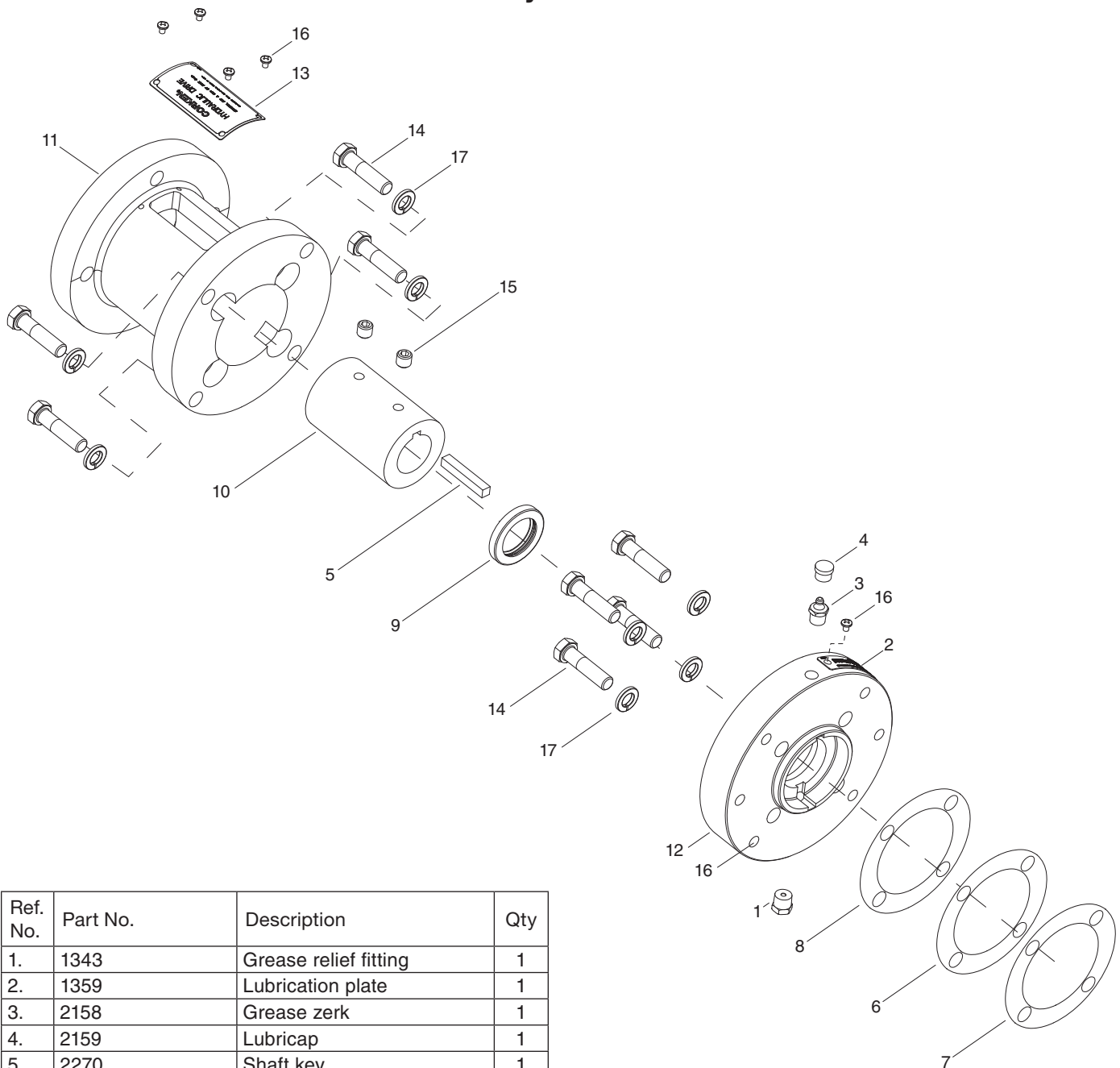

Ref. No.	Part No.	Description	Qty
1.	1343	Grease relief fitting	1
2.	1359	Lubrication plate	1
3.	2158	Grease zerk	1
4.	2159	Lubricap	1
5.	2270	Shaft key	1
6.	4439	Bearing cap shim—0.002"	1
7.	4439-1	Bearing cap shim—0.010"	1
8.	4439-2	Bearing cap shim—0.020"	1
9.	4463	Grease seal	1
10.	4487-2	Hydraulic drive solid coupling	1
11.	4496-1	Hydraulic drive bracket	1
12.	4939	Hydraulic drive bearing cap	1
13.	4499	Hydraulic drive name plate	1
14.	7001-037NC150A	Bolt—hexagon head	8
15.	7006-037NC037A	Set screw	2
16.	7012-006SF019E	Screw	6
17.	7206-037A	Lock washer—0.375"	8

Appendix F—V-Belt Selection for Stationary Coro-Vane® Pumps

1,450 RPM Motor			Motor Hp	Nominal Pump RPM	1,750 RPM Motor		
Belt Number	Sheave Pitch Diameter				Sheave Pitch Diameter		Belt Number
	Pump	Motor			Pump	Motor	
B64	B15.4	B7.4	2	420	1-3V14.0	1-3V3.35	3V600
B60	B13.6	B4.2		470	1-3V10.6	1-3V2.80	3V530
B60	B12.4	B4.2		520	1-3V10.6	1-3V3.15	3V530
B55	B11.0	B4.2		580	1-3V10.6	1-3V3.65	3V560
B56	B11.0	B4.8		640	1-3V8.0	1-3V3.00	3V500
B64	B15.4	B4.4	3	420	2-3V10.6	2-3V2.65	3V530
B64	B15.4	B4.8		470	2-3V10.6	2-3V2.80	3V530
A55	2A10.6	2A3.6		520	1-3V14.0	1-3V4.12	3V630
B55	2B11.0	2B4.2		580	1-3V14.0	1-3V4.75	3V630
B60	B12.4	B5.4		640	2-3V8.0	2-3V3.00	3V500
B56	B11.0	B5.2		710	2-3V6.9	2-3V2.80	3V475
B53	B9.4	B4.8		780	1-3V8.0	1-3V3.65	3V500
B53	B8.6	B5.0		860	2-3V5.3	2-3V2.65	3V450
B51	B7.4	B4.8		950	1-3V6.5	1-3V3.65	3V475
B64	2B15.4	2B4.4	5	420	3-A13.2	3-A3.2	A60
B60	2B13.6	2B4.2		470	2-A13.2	2-A3.6	A60
B60	2B12.4	2B4.2		520	2-A12.0	2-A3.6	A56
B55	2B11.0	2B4.2		580	2-3V10.6	2-3V3.65	3V560
B56	2B11.0	2B4.8		640	3-3V8.0	3-3V3.00	3V500
B56	2B11.0	2B5.2		710	2-3V8.0	2-3V3.35	3V500
B53	2B9.4	2B4.8		780	2-3V6.9	2-3V3.15	3V475
B53	2B8.6	2B5.0		860	2-3V6.5	2-3V3.15	3V475
B51	2B7.4	2B4.8		950	2-3V6.0	2-3V3.35	3V475
B64	3B15.4	3B4.4	7-1/2	420	4-A13.2	4-A3.2	A60
B64	2B15.4	2B4.8		470	3-A13.2	3-A3.6	A60
B60	3B12.7	3B4.2		520	3-3V14.0	3-3V4.12	3V630
B55	3B11.0	3B4.2		580	2-3V14.0	2-3V4.75	3V630
B56	3B11.0	3B4.8		640	2-3V14.0	2-3V5.30	3V630
B56	3B11.0	3B5.2		710	2-3V10.6	2-3V4.50	3V560
B53	3B9.4	3B4.8		780	3-3V6.9	3-3V3.15	3V475
B53	3B8.6	3B5.0		860	3-3V6.5	3-3V3.15	3V475
B51	3B7.4	3B4.8		950	2-3V8.0	2-3V4.50	3V530
B71	3B18.4	3B5.2	10	420	3-3V19.0	3-3V4.50	3V710
B71	2B18.4	2B5.8		470	3-3V19.0	3-3V5.00	3V710
B60	4B12.4	4B4.2		520	3-3V14.0	3-3V4.12	3V630
B55	4B11.0	4B4.2		580	3-3V14.0	3-3V4.50	3V630
B56	4B11.0	4B4.8		640	2-3V14.0	2-3V5.30	3V630
B62	3B12.4	3B5.8		710	2-3V14.0	2-3V5.60	3V630
B56	3B11.0	3B5.8		780	2-B12.4	2-B5.6	B60
B62	3B12.4	3B7.0		860	2-3V10.6	2-3V5.30	3V560
B60	3B9.4	3B6.0		950	2-3V10.6	2-3V5.60	3V560
B71	4B18.4	4B5.2	15	420	4-3V19.0	4-3V4.75	3V710
B71	3B18.4	3B5.8		470	4-3V19.0	4-3V5.00	3V710
B62	5B13.6	5B4.8		520	3-3V19.0	3-3V5.60	3V750
B60	5B12.4	5B4.8		580	4-3V14.0	4-3V4.75	3V630
B56	5B11.0	5B4.8		640	3-3V14.0	3-3V5.30	3V630
B56	5B11.0	5B5.2		710	3-3V14.0	3-3V5.60	3V630
B53	5B9.4	5B4.8		780	3-B12.4	3-B5.6	B60
B53	5B8.6	5B5.0		860	2-B12.4	2-B6.0	B60
B51	5B7.4	5B4.8		950	2-B11.0	2-B6.0	B56
B75	4B18.4	4B6.6	20	520	4-3V19.0	4-3V5.60	3V750
B68	4B15.4	4B6.8		640	4-3V14.0	4-3V5.30	3V630
B64	4B12.4	4B6.6		780	3-B13.6	3-B6.0	B62
B68	3B13.6	3B8.0		860	4-3V10.6	4-3V5.30	3V560
B65	3B12.4	3B8.0		950	3-B11.0	3-B6.0	B56
5VX680	4-5V15.00	4-5V5.50	25	520	4-B18.4	4-B5.2	BX76
5VX700	3-5V14.0	3-5V6.30		640	4-B16.0	4-B5.6	BX70
5VX680	3-5V12.5	3-5V6.70		780	3-B15.4	3-B7.4	BX71
5VX660	3-5V11.3	3-5V6.70		860	4-B15.4	4-B6.6	BX70

Appendix F—V-Belt Selection for the Z4500

1,450 RPM Motor			Motor Hp	Nominal Pump RPM	1,750 RPM Motor		
Belt Number	Sheave Pitch Diameter				Sheave Pitch Diameter		Belt Number
	Pump	Motor			Pump	Motor	
3VX690	QD3/3V14.00	QD3/3V4.12	7.5	420	QD3/3V19.00	QD3/3V4.75	3/3V800
3VX710	QD3/3V14.00	QD3/3V4.50		470	QD2/3V19.00	QD2/3V5.30	3VX800
3VX710	QD3/3V14.00	QD3/3V5.00		520	QD3/3V14.00	QD3/3V4.12	3VX690
3VX630	QD3/3V10.60	QD3/3V4.12		580	QD3/3V14.00	QD3/3V4.50	3VX710
3VX650	QD3/3V10.60	QD3/3V4.75		640	QD2/3V14.00	QD2/3V5.30	3VX710
2/3VX710	QD2/3V14.00	QD2/3V6.90		710	QD3/3V10.60	QD3/3V4.50	3V650
3VX650	QD2/3V10.60	QD2/3V5.60		780	QD2/3V14.00	QD2/3V6.50	2/3VX710
3VX600	QD3/3V8.00	QD3/3V4.75		860	QD2/3V10.60	QD2/3V5.30	3VX650
3VX580	QD3/3V6.90	QD3/3V4.50		950	QD2/3V10.60	QD2/3V6.00	3VX670
3VX690	QD3/3V14.00	QD3/3V4.12		10	420	QD3/3V14.00	QD3/3V3.35
3VX710	QD2/3V14.00	QD2/3V4.75	470		QD3/3V14.00	QD3/3V3.65	3VX690
3VX710	QD2/3V14.00	QD2/3V5.00	520		QD3/3V10.60	QD3/3V3.15	3VX616
3VX710	QD2/3V14.00	QD2/3V5.60	580		QD2A15.6/B16.0	QD2A4.8/B5.2	2/B72
3VX650	QD2/3V10.60	QD2/3V4.75	640		QD2A15.0/B15.4	QD2A5.0/B5.4	2/B71
3VX650	QD2/3V10.60	QD2/3V5.30	710		QD1A15.6/B16.0	QD1A6.0/B6.4	B74
3VX570	QD3/3V6.90	QD3/3V3.65	780		QD2/3V10.60	QD2/3V4.75	3VX650
3VX600	QD2/3V8.00	QD2/3V4.75	860		QD2/3V10.60	QD2/3V5.30	3VX650
3VX580	QD2/3V6.90	QD2/3V4.50	950		QD3/3V6.00	QD3/3V3.35	3VX550
3/3VX800	QD3/3V19.00	QD3/3V5.60	15		420	QD3/3V25.00	QD3/3V6.00
3/3VX800	QD3/3V19.00	QD3/3V6.00		470	QD3/3V19.00	QD3/3V5.30	3VX800
3V830	QD3/3V19.00	QD3/3V6.90		520	QD3/3V19.00	QD3/3V5.60	3/3VX800
3VX710	QD3/3V14.00	QD3/3V5.60		580	QD3/3V19.00	QD3/3V6.50	3V810
3V730	QD3/3V14.00	QD3/3V6.00		640	QD3/3V14.00	QD3/3V5.30	3/3V710
3/3VX710	QD3/3V14.00	QD3/3V6.90		710	QD3/3V14.00	QD3/3V5.60	3VX710
3VX650	QD3/3V10.60	QD3/3V5.60		780	QD3/3V10.60	QD3/3V4.75	3VX650
3/3VX670	QD3/3V10.60	QD3/3V6.50		860	QD3/3V10.60	QD3/3V5.30	3VX650
3/3VX670	QD3/3V10.60	QD3/3V6.90		950	QD3/3V10.60	QD3/3V6.00	3VX670
B78	QD3A18.0/B18.4	QD3A6.0/B6.4		20	520	QD3A18.0/B18.4	QD3A5.0/B5.4
B73	QD3A15.0/B15.4	QD3A6.2/B6.6	640		QD3A18.0/B18.4	QD3A6.0/B6.4	3/B78
B68	QD3A12.0/B12.4	QD3A6.2/B6.6	780		QD3A15.0/B15.4	QD3A6.4/B6.8	3/B73
B65	QD3A10.6/B11.0	QD3A6.0/B6.4	860		QD3A13.2/B13.6	QDA6.2/B6.6	3/B70
B78	QD4A18.0/B18.4	QD4A6.0/B6.4	25	520	QD3/5V18.70	QD3/5V5.50	3/5VX800
B80	QD3A18.0/B18.4	QD3A7.6/B8.0		640	QD3A18.0/B18.4	QD3A6.2/B6.6	3/B78
B75	QD3A15.0/B15.4	QD3A7.6/B8.0		780	QD3/5V10.90	QD3/5V4.90	5VX650
B72	QD3A13.2/B13.6	QD3A7.6/B8.0		860	QD3A13.2/B13.6	QD3A6.2/B6.6	3/B70

Appendix G—Troubleshooting Guide

In diagnosing pump and system troubles, record the following data during product transfers:

1. Pressure at pump suction.
2. Pressure at pump discharge.
3. Pressure in truck tank.
4. Pressure in tank being filled.
5. Pipe size and length of suction and discharge lines.
6. Size and length of vapor equalizing line.
7. Pump speed if practical.

Problem	Cause	Solution
Low capacity	Pump speed too slow	Check engine speed and PTO on pulley ratio. Consult pump performance curve. Use tachometer on pump if speed is questionable.
	High differential pressure	Restriction in discharge piping or hose too small. Vapor equalization lines too small or not used.
	External bypass valve stuck open or set too low	Readjust, repair, or replace valve.
	Clogged strainer	Clean strainer.

Appendix G—Troubleshooting Guide (continued)

Problem	Cause	Solution
Low capacity (continued)	Suction pipe too small or restricted	Indicated by pump inlet pressure dropping several pounds when pump is started. Remove restriction or modify piping.
	Worn vanes	Replace.
	Pump without vapor return	Without vapor equalization, a pump can remove only about 3% of the truck tank capacity per minute without severe cavitation and capacity loss.
	Worn sideplates	Reverse or replace sideplates. Check universal drive assembly to make sure angularity is within limits, yokes are parallel and slip-joint is greased. Check bearings. Check pulley alignment on belt drive pumps.
	Vanes sticking	Remove vanes and clean out foreign matter (check strainer). Replace vanes if swollen.
Pump runs but no flow	Valve closed	Check valves. Make sure internal tank excess flow valve is open! Refer to manufacturer's instructions.
	Excess flow valve slugged	Stop pump until valve opens. If problem continues, slow pump down or install a new or larger excess flow valve.
	Broken shaft	Disassemble and inspect pump. Repair if necessary.
	Defective meter	Service meter.
Pump will not turn—locked up	Foreign matter in pump	Clean out the pump—check strainer in suction line.
	Vanes broken	Clean out pump carefully and replace vanes. Has pump been operated dry? Then, check for damage to cam and rotor shaft assembly.
	Bearing seized	Replace pump bearings. Grease monthly. Use ball bearing grease manufactured for intended service.
	Moisture frozen in pump	Let thaw and break loose carefully. Add methanol to tank (on LP-Gas). Check with product supplier about possibility of water in gas.
Will not build pressure	Poor suction conditions	Clean inlet strainer. Increase pipe size.
	External bypass valve set too low	Set valve for higher pressure—see instructions. See IH102 and IH106 IOM manuals for more information.
	Worn vanes and/or sideplates	Disassemble, inspect and repair as necessary. Do not run dry!
Pump is noisy	Cavitation from poor suction conditions	As above.
	Vanes sticking	As above.
	Bearings worn	Replace—grease monthly.
	Meter screen clogged	Clean
	Very high differential pressure	Check for restriction in discharge line. Delivery hose too small and too long. Slow down pump!
		Check vapor release float assembly on meter and meter differential valve.
	PTO shaft vibration	Inspect and repair driveline component.
Pump leaks around shaft	Seal or O-rings failed	Inspect seal assembly and replace if necessary. Keep new seal very clean when replacing seal. Recommend a light oil film on O-rings. Do not run pump dry!

Appendix H—Storage of the Z-Series Coro-Vane® Pump

If your Corken Z-Series pump is to be removed from service for some time, the pump must be protected as propane, butane and anhydrous ammonia all leave the metal “bare” and open to corrosion. Piping and tanks not in service should also be protected, as the rust particles can destroy the pump’s seals almost immediately after startup.

1. Fill or thoroughly flush the pump with a light rust inhibiting oil. (If the pump is flushed with oil, placing some desiccant packets inside the pump will provide added protection.)
2. Plug all pump openings.
3. Store in a dry location.
4. Before placing the pump back into service, drain the oil and remove any desiccant packets.
5. Refer to the “OPERATION OF YOUR PUMP” section of this manual.

Appendix I—Hydraulic Motor Specifications¹

Operating Specifications for Char-Lynn Hydraulic Motor

Mounting flange	2 bolt SAE A
Input shaft	1 in. diameter straight keyed
Port ‘A’	7/8-14 O-ring
Port ‘B’	7/8-14 O-ring
Pilot diameter	3.250/3.245 in. (57.15/57.02 mm)
Motor displacement	6.2 cubic in. per revolution
Maximum speed continuous duty	742 RPM
Flow continuous duty	20 gpm (76 L/min)
Torque continuous duty	3,500 in•lb (395.5 N•M)
Case drain	7/16-20 O-ring
Recommended fluids	Premium quality anti-wear
Minimum viscosity	70 SSU (13 cSt)
Maximum operating temperature	180°F (82°C)

¹Data applies to this particular motor only. Your application may vary, please consult factory for details.

Solutions beyond products...

CORKEN
IDEX

CORKEN, INC. • A Unit of IDEX Corporation

9201 North I-35 Service Road, Oklahoma City, OK. 73131

Phone (405) 946-5576 • Fax (405) 948-7343

Visit our website at <http://www.corken.com>

or e-mail us at cocsalesdept@idexcorp.com



@CorkenInc

