

Version mobile sur chariot
Mobile version on trolley

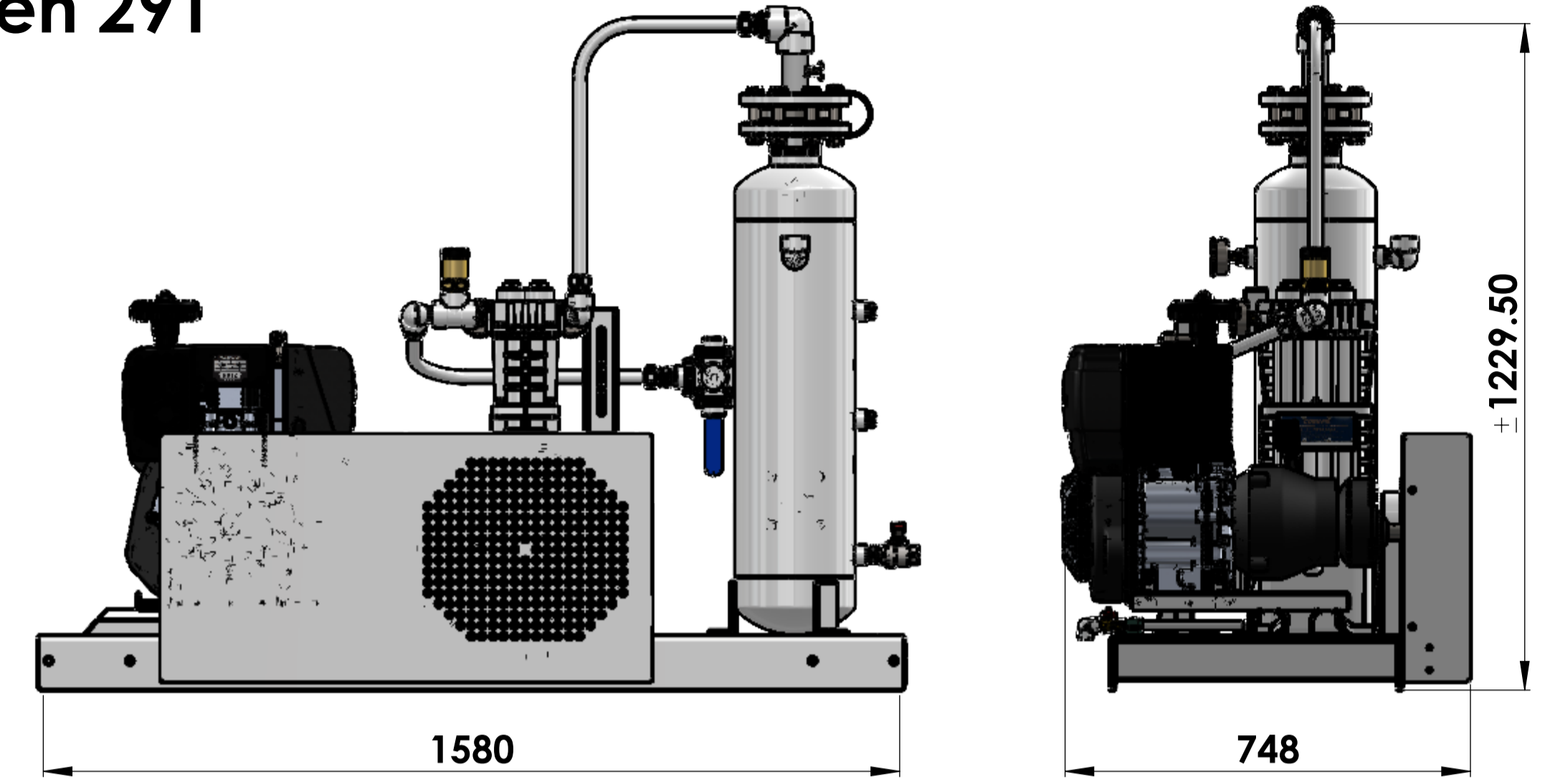

GRUPE MOTO-COMPRESSEUR DIESEL CORKEN 291 (GMC10D291)

Diesel Compression unit Corken 291



Manomètres aspiration et refoulement
Pressure gauges on inlet and outlet

Soupape 1.25" 17 bar
Relief valve 1.25" NPT 17 bar

Carter courroies amovible
Removable belt cover

Arrêt d'urgence
Emergency stop

Piège à liquide 28 litres
Liquid trap 28L

Vanne 4 voies
4 way valve

Filtre
Strainer

Robinet de purge
Drain valve

Pare étincelle
Spark arrestor

Moteur diesel Hatz 1B40 + embrayage
Diesel engine Hatz with manual clutch

Chassis renforcé, peinture blanche
Reinforced base plate, white painted

Compresseur Corken 291 Am3FBANSNN
Corken compressor

Vidange d'huile
Oil drain valve

Manomètre de pression d'huile
Oil pressure gauge

Performances:
23m³/hr
Pms 21 bar

Dess: JDP / Date: 06/01/2022 / Echelle / Scale: 1:4	Traitement / finishing :	Revision
© - A1 / Tol. générale / General tol.: +/- 0,1	GRUPE MOTOCOMPRESSEUR 291 DIESEL	
<small>THE INFORMATION CONTAINED IN THIS DRAWING IS THE SOLE PROPERTY OF EQUIP-FLUIDES. ANY REPRODUCTION IN PART OR AS A WHOLE WITHOUT THE WRITTEN PERMISSION OF EQUIP-FLUIDES IS PROHIBITED.</small> EQUIP FLUIDES 2 Rue Lavoisier, 77465 Logny s/ Marne (FRANCE) EQUIP FLUIDES ☎ (+33) 01.64.12.46.03 ☎ (+33) 01.64.12.46.17	REF PLAN: GMC10D291	REF PIECE: GMC10D291