

# Appendix D—Outline Dimensions for Models D51 and F51

## Model D51 (Direct Mount)

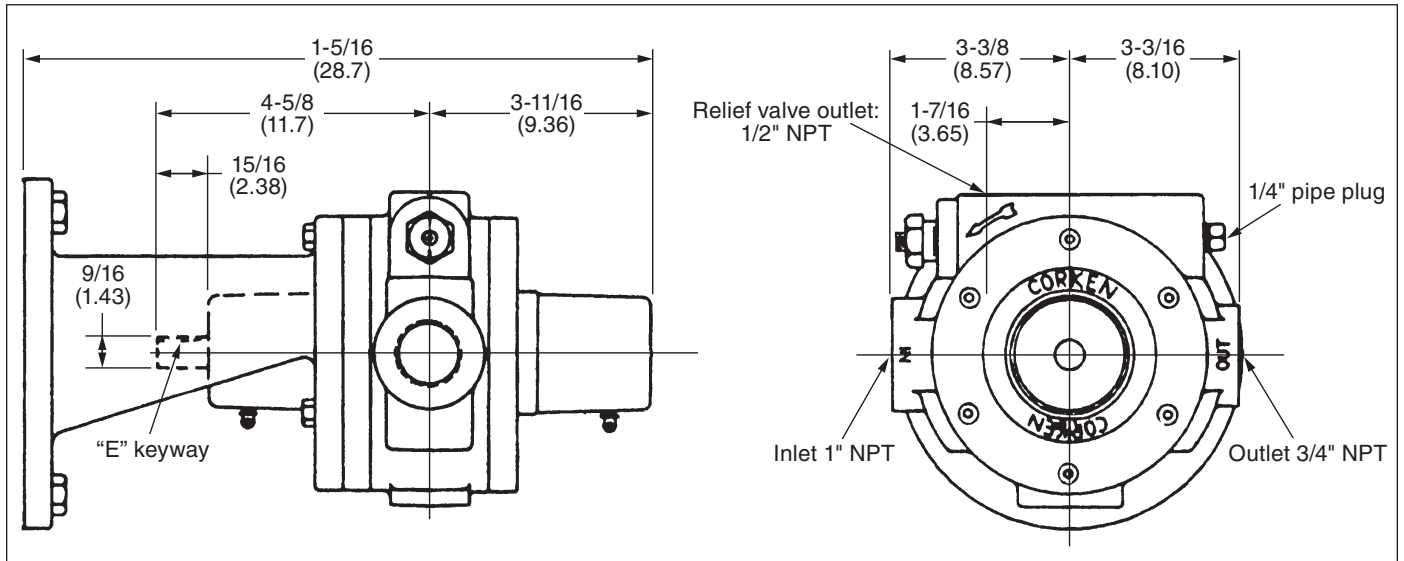

## Model F51 (Frame Mount)

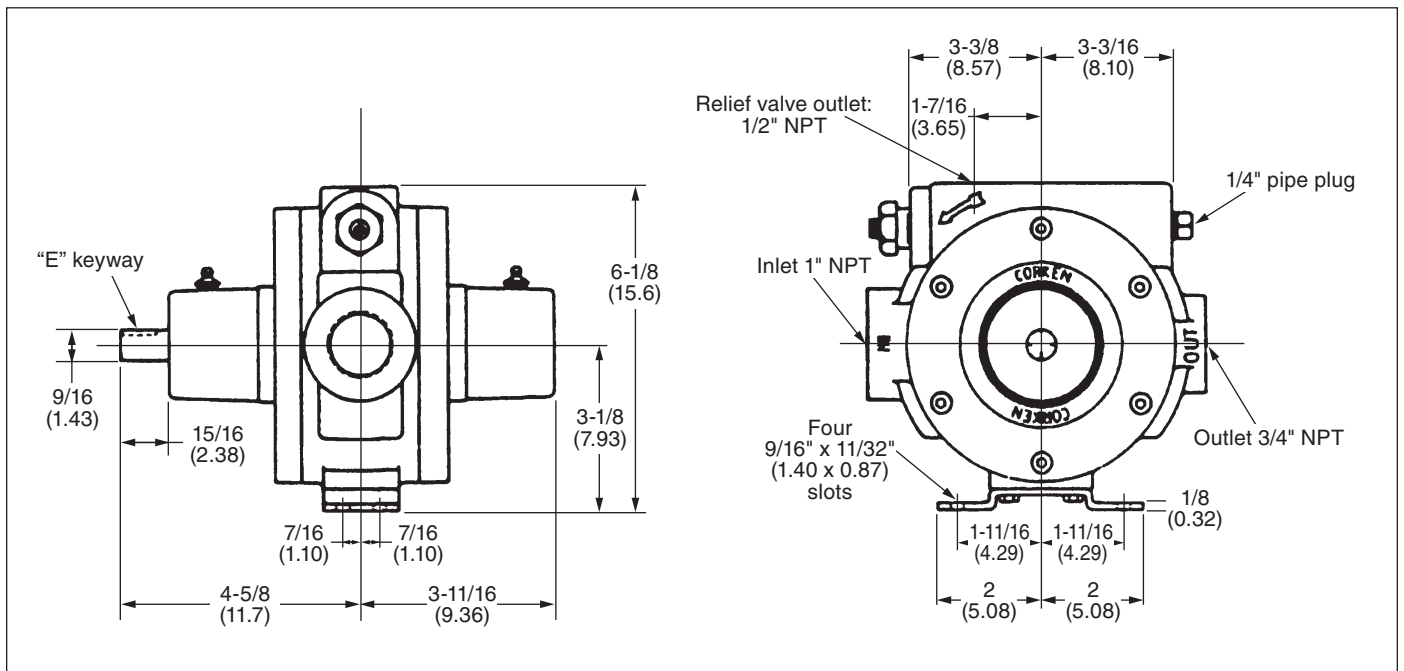

All dimensions are in inches (centimeters).

# Appendix D—Outline Dimensions for Model F51-101 (Frame Mount)

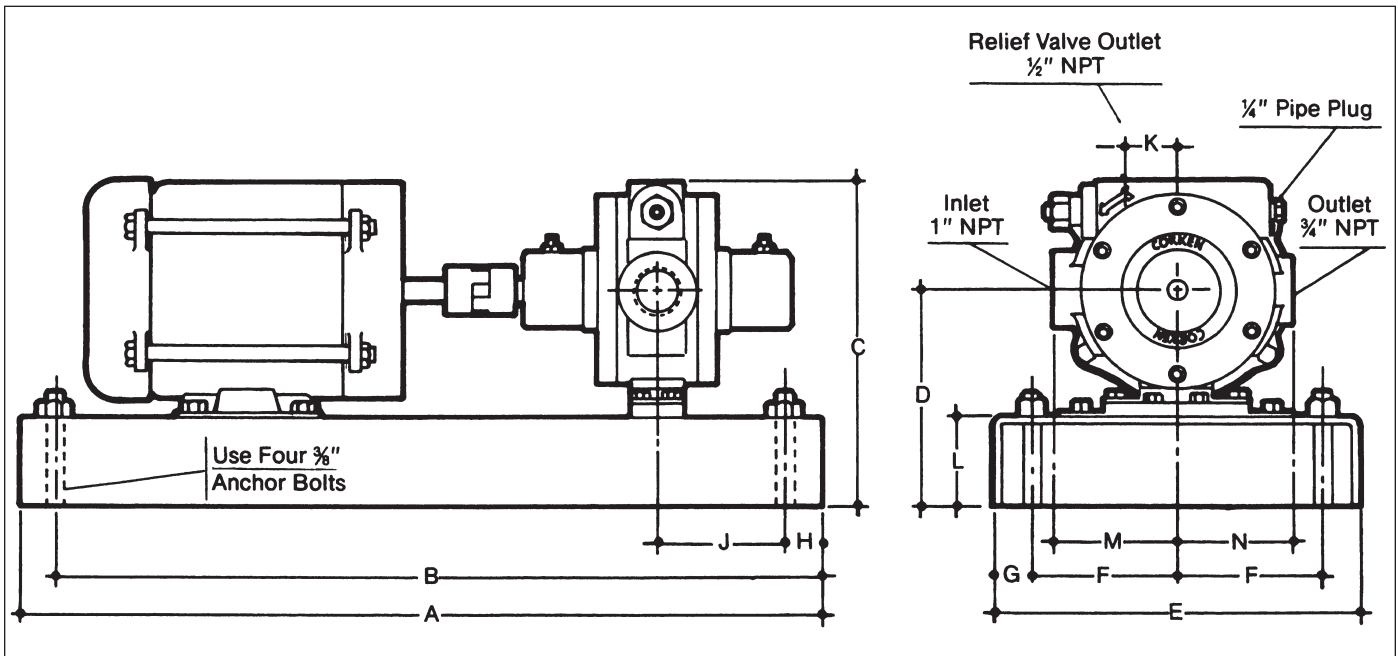

A	B	C	D	E	F	G	H	J	K	L	M	N
22 (55.90)	20 (50.80)	9 (22.90)	6 (15.20)	10 (25.40)	4 (10.20)	1 (2.54)	1 (2.54)	3-1/2 (8.89)	1-7/16 (3.65)	2-1/2 (6.35)	3-3/8 (8.57)	3-3/16 (8.10)

All dimensions are in inches (centimeters).

# Appendix D—Outline Dimensions for Models 521 and 1021

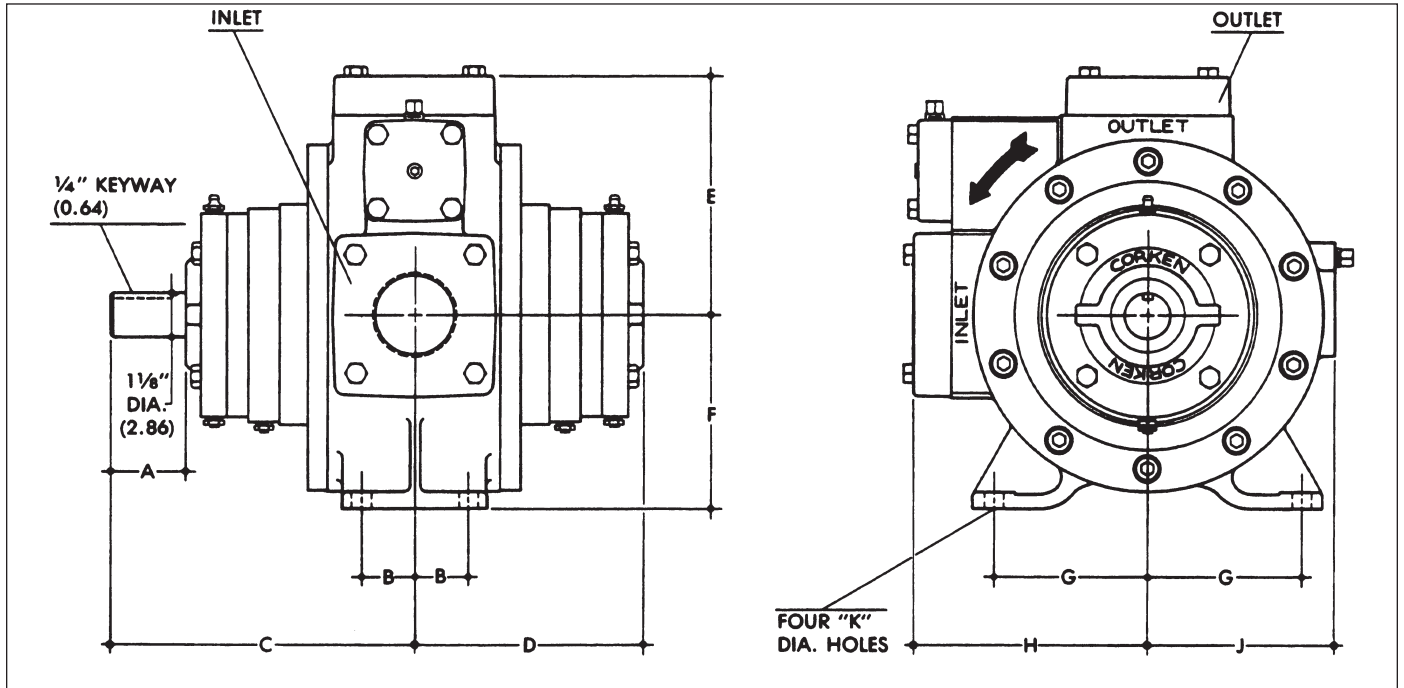

Model	Inlet	Outlet	A	B	C	D	E	F	G	H	J	K
521	STD: 2-1/2" NPT OPT: 2" NPT 2", 2-1/2" Weld	STD: 2" NPT OPT: 1-1/2", 2-1/2" NPT 1-1/2", 2", 2-1/2" Weld	1-31/32 (5.00)	1-3/8 (3.49)	7-7/8 (20.00)	5-29/32 (15.00)	6-1/8 (15.56)	5 (12.70)	4 (10.16)	6-1/8 (15.56)	4-11/16 (11.91)	1/2 (1.27)
1021	STD: 3" NPT OPT: 4" NPT 3", 4" Weld	STD: 3" NPT OPT: 4" NPT 3", 4" Weld	2 (5.08)	1-3/4 (4.45)	8-1/2 (21.59)	6-7/16 (16.35)	7-1/16 (17.94)	5-1/2 (13.97)	4-1/8 (10.48)	7-1/16 (17.94)	5-3/8 (13.65)	1/2 (1.27)

All dimensions are in inches (centimeters).

# Appendix D—Outline Dimensions for Models F1021

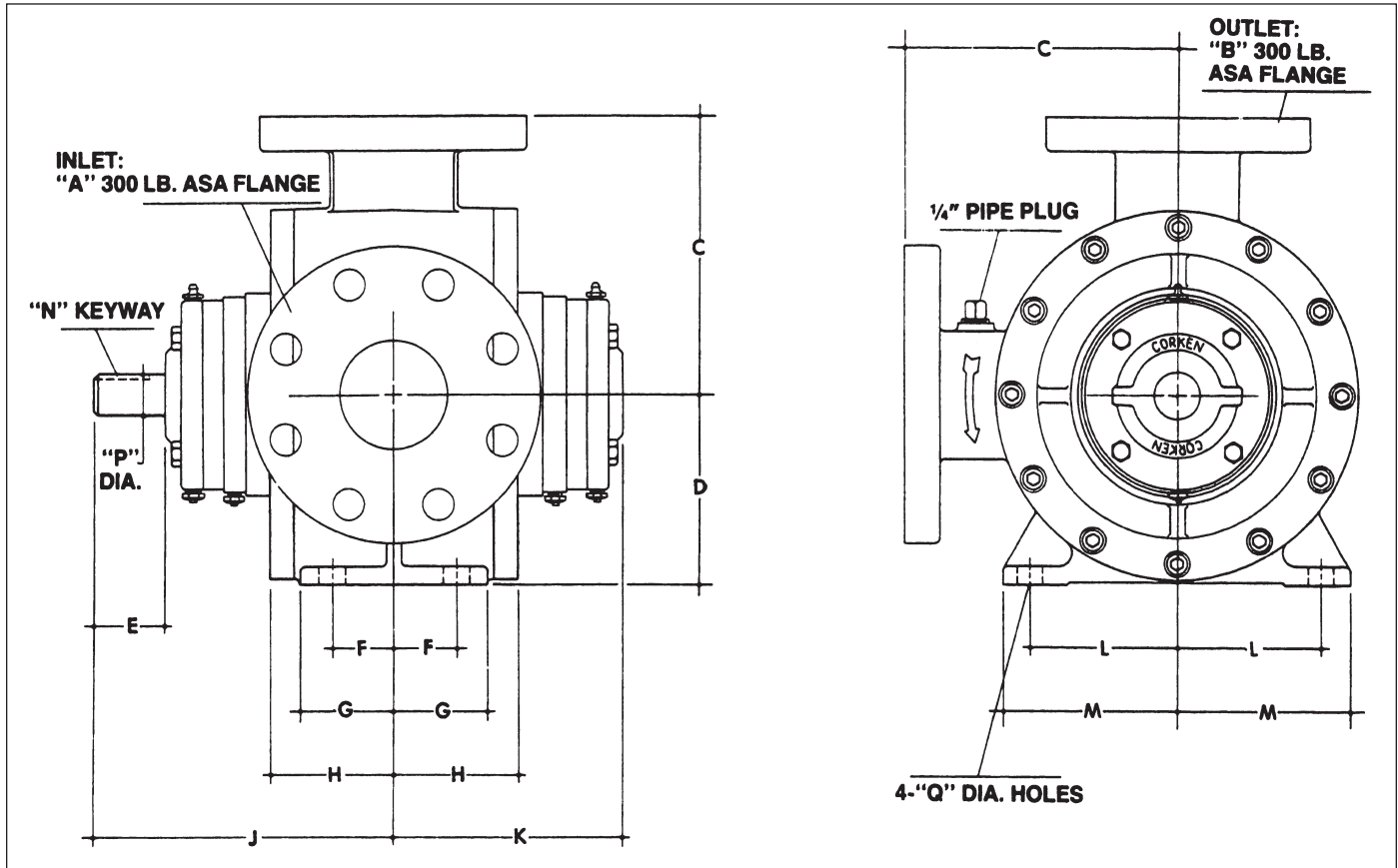

Model	A	B	C	D	E	F	G	H	J	K	L	M	N	P	Q
F1021	3	2-1/2	7-3/4 (19.70)	5-1/2 (14.00)	2 (5.10)	1-3/4 (4.40)	2-5/8 (6.70)	3-1/2 (8.90)	8-1/2 (21.60)	6-1/2 (16.50)	4-1/8 (10.50)	4-15/16 (12.50)	1/4 (0.64)	1-1/8 (2.90)	1/2 (1.27)

All dimensions are in inches (centimeters).

# Appendix D—Outline Dimensions for Models 521 and 1021-103

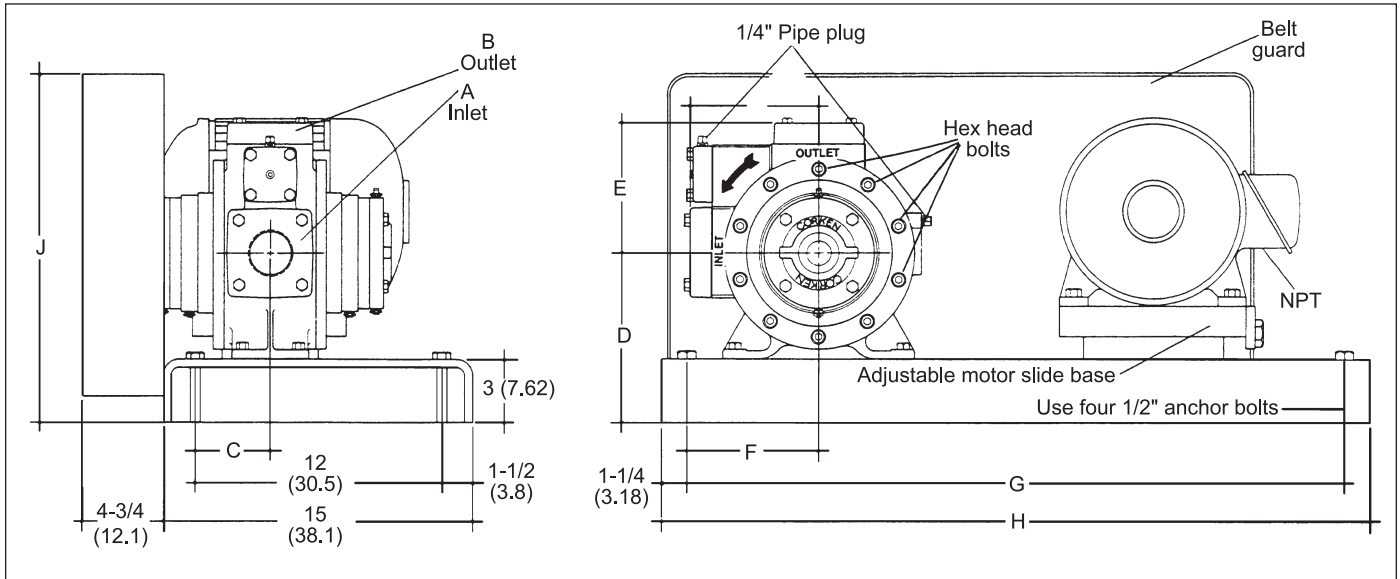

## Flange Dimensions

Model	A (inlet)	B (outlet)
521	Standard: 2-1/2" NPT	Standard: 2" NPT
	Optional: 2" NPT	Optional: 1-1/2", 2-1/2" NPT
1021	Standard: 3" NPT	Standard: 3" NPT
	Optional: 4" NPT	Optional: 4" NPT

## 521-103 Dimensions

Motor		Pump Speed	C	D	E	F	G	H	J
Hp	Frame <sup>1</sup>								
2	145T	All	3-5/8 (9.21)	8 (20.30)	6-1/8 (15.60)	6-1/4 (15.90)	31-1/2 (80.00)	34 (86.40)	16-1/2 (41.90)
2	182T	All	3-5/8 (9.21)	8 (20.30)	6-1/8 (15.60)	6-1/4 (15.90)	31-1/2 (80.00)	34 (86.40)	16-1/2 (41.90)
3	182T	All	3-5/8 (9.21)	8 (20.30)	6-1/8 (15.60)	6-1/4 (15.90)	31-1/2 (80.00)	34 (86.40)	16-1/2 (41.90)
3	184T	All	3-5/8 (9.21)	8 (20.30)	6-1/8 (15.60)	6-1/4 (15.90)	31-1/2 (80.00)	34 (86.40)	16-1/2 (41.90)
5	184T	All	3-5/8 (9.21)	8 (20.30)	6-1/8 (15.60)	6-1/4 (15.90)	31-1/2 (80.00)	34 (86.40)	16-1/2 (41.90)
7-1/2	213T	All	3-5/8 (9.21)	8 (20.30)	6-1/8 (15.60)	6-1/4 (15.90)	31-1/2 (80.00)	34 (86.40)	16-1/2 (41.90)
10	215T	420-470	3-5/8 (9.21)	10-3/4 (27.30)	6-1/8 (15.60)	9-1/4 (23.50)	39-1/2 (100.30)	42 (106.70)	19-3/4 (50.20)
10	215T	520-950	3-5/8 (9.21)	8 (20.30)	6-1/8 (15.60)	6-1/4 (15.90)	31-1/2 (80.00)	34 (86.40)	16-1/2 (41.90)

## 1021-103 Dimensions

Motor		Pump Speed	C	D	E	F	G	H	J
Hp	Frame <sup>1</sup>								
3	182T	All	4-1/2 (10.80)	8-1/2 (21.60)	7-3/16 (18.30)	6-1/4 (15.90)	31-1/2 (80.00)	34 (86.40)	16-1/2 (41.90)
3	182T	All	4-1/2 (10.80)	8-1/2 (21.60)	7-3/16 (18.30)	6-1/4 (15.90)	31-1/2 (80.00)	34 (86.40)	16-1/2 (41.90)
5	184T	All	4-1/2 (10.80)	8-1/2 (21.60)	7-3/16 (18.30)	6-1/4 (15.90)	31-1/2 (80.00)	34 (86.40)	16-1/2 (41.90)
7-1/2	213T	All	4-1/2 (10.80)	8-1/2 (21.60)	7-3/16 (18.30)	6-1/4 (15.90)	31-1/2 (80.00)	34 (86.40)	16-1/2 (41.90)
10	215T	420-470	4-1/2 (10.80)	10-1/2 (26.70)	7-3/16 (18.30)	9-1/4 (23.50)	39-1/2 (100.30)	42 (106.70)	19-3/4 (50.20)
10	215T	520-950	4-1/2 (10.80)	8-1/2 (21.60)	7-3/16 (18.30)	6-1/4 (15.90)	31-1/2 (80.00)	34 (86.40)	16-1/2 (41.90)
15	254T	420-520	4-1/2 (10.80)	10-1/2 (26.70)	7-3/16 (18.30)	9-1/4 (23.50)	39-1/2 (100.30)	42 (106.70)	19-3/4 (50.20)
15	254T	580-950	4-1/2 (10.80)	8-1/2 (21.60)	7-3/16 (18.30)	6-1/4 (15.90)	31-1/2 (80.00)	34 (86.40)	16-1/2 (41.90)
20	256T	520	4-1/2 (10.80)	10-1/2 (26.70)	7-3/16 (18.30)	9-1/4 (23.50)	39-1/2 (100.30)	42 (106.70)	19-3/4 (50.20)
20	256T	640-950	4-1/2 (10.80)	8-1/2 (21.60)	7-3/16 (18.30)	6-1/4 (15.90)	31-1/2 (80.00)	34 (86.40)	16-1/2 (41.90)

<sup>1</sup> All dimensions based on a motor speed of 1,750 RPM.

All dimensions are in inches (centimeters).

# Appendix D—Outline Dimensions for Models F1021

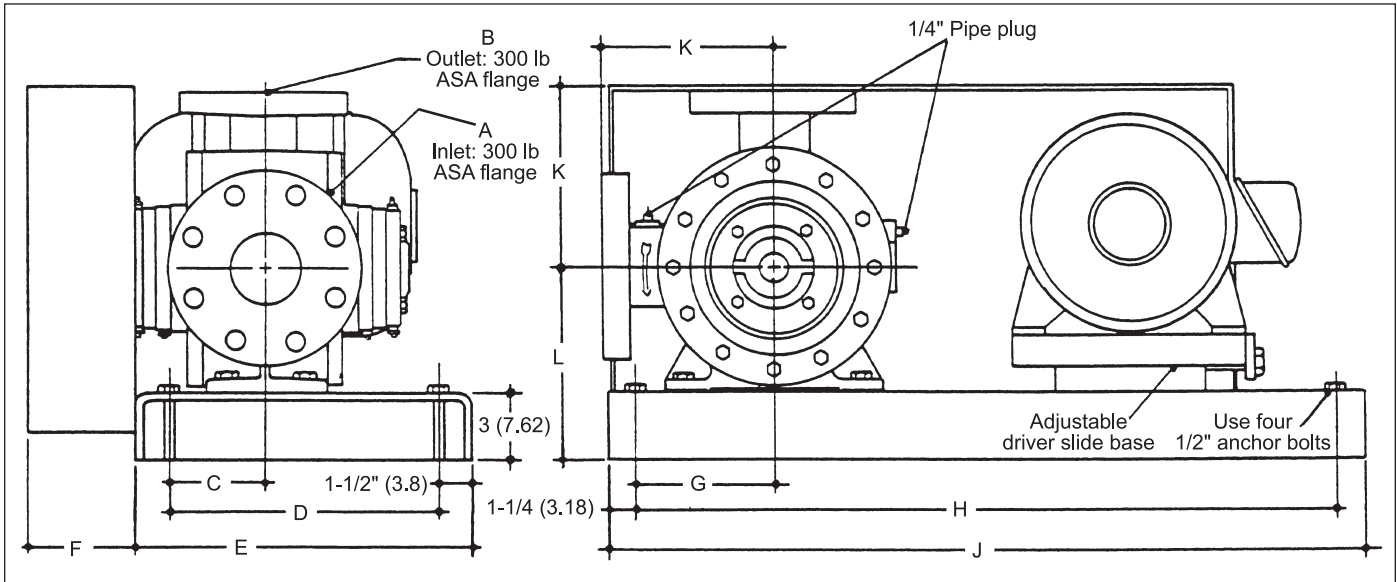

## Flange Dimensions

Model	A (inlet)	B (outlet)
F1021	3" 300# ANSI	2-1/2" 300# ANSI

## F1021-103 Dimensions

Motor		Pump Speed	C	D	E	F	G	H	J	K	L
Hp	Frame <sup>1</sup>										
3	182T	All	4-1/4 (10.80)	12 (30.50)	15 (38.10)	5 (12.70)	6-1/4 (15.90)	31-1/2 (80)	34 (86.40)	7-3/4 (19.70)	8-1/2 (21.60)
3	182T	All	4-1/4 (10.80)	12 (30.50)	15 (38.10)	5 (12.70)	6-1/4 (15.90)	31-1/2 (80)	34 (86.40)	7-3/4 (19.70)	8-1/2 (21.60)
5	184T	All	4-1/4 (10.80)	12 (30.50)	15 (38.10)	5 (12.70)	6-1/4 (15.90)	31-1/2 (80)	34 (86.40)	7-3/4 (19.70)	8-1/2 (21.60)
7-1/2	213T	All	4-1/4 (10.80)	12 (30.50)	15 (38.10)	5 (12.70)	6-1/4 (15.90)	31-1/2 (80)	34 (86.40)	7-3/4 (19.70)	8-1/2 (21.60)
10	215T	420-470	4-1/4 (10.80)	12 (30.50)	15 (38.10)	5 (12.70)	9-1/4 (23.50)	39-1/2 (100.30)	42 (106.70)	7-3/4 (19.70)	10-1/2 (26.70)
10	215T	520-950	4-1/4 (10.80)	12 (30.50)	15 (38.10)	5 (12.70)	6-1/4 (15.90)	31-1/2 (80)	34 (86.40)	7-3/4 (19.70)	8-1/2 (21.60)
15	254T	420-520	4-1/4 (10.80)	12 (30.50)	15 (38.10)	5 (12.70)	9-1/4 (23.50)	39-1/2 (100.30)	42 (106.70)	7-3/4 (19.70)	10-1/2 (26.70)
15	254T	580-950	4-1/4 (10.80)	12 (30.50)	15 (38.10)	5 (12.70)	6-1/4 (15.90)	31-1/2 (80)	34 (86.40)	7-3/4 (19.70)	8-1/2 (21.60)
20	256T	520	4-1/4 (10.80)	12 (30.50)	15 (38.10)	5 (12.70)	9-1/4 (23.50)	39-1/2 (100.30)	42 (106.70)	7-3/4 (19.70)	10-1/2 (26.70)
20	256T	640-950	4-1/4 (10.80)	12 (30.50)	15 (38.10)	5 (12.70)	6-1/4 (15.90)	31-1/2 (80)	34 (86.40)	7-3/4 (19.70)	8-1/2 (21.60)

<sup>1</sup> All dimensions based on a motor speed of 1,750 RPM.

# Appendix D—Outline Dimensions for Model Z2000

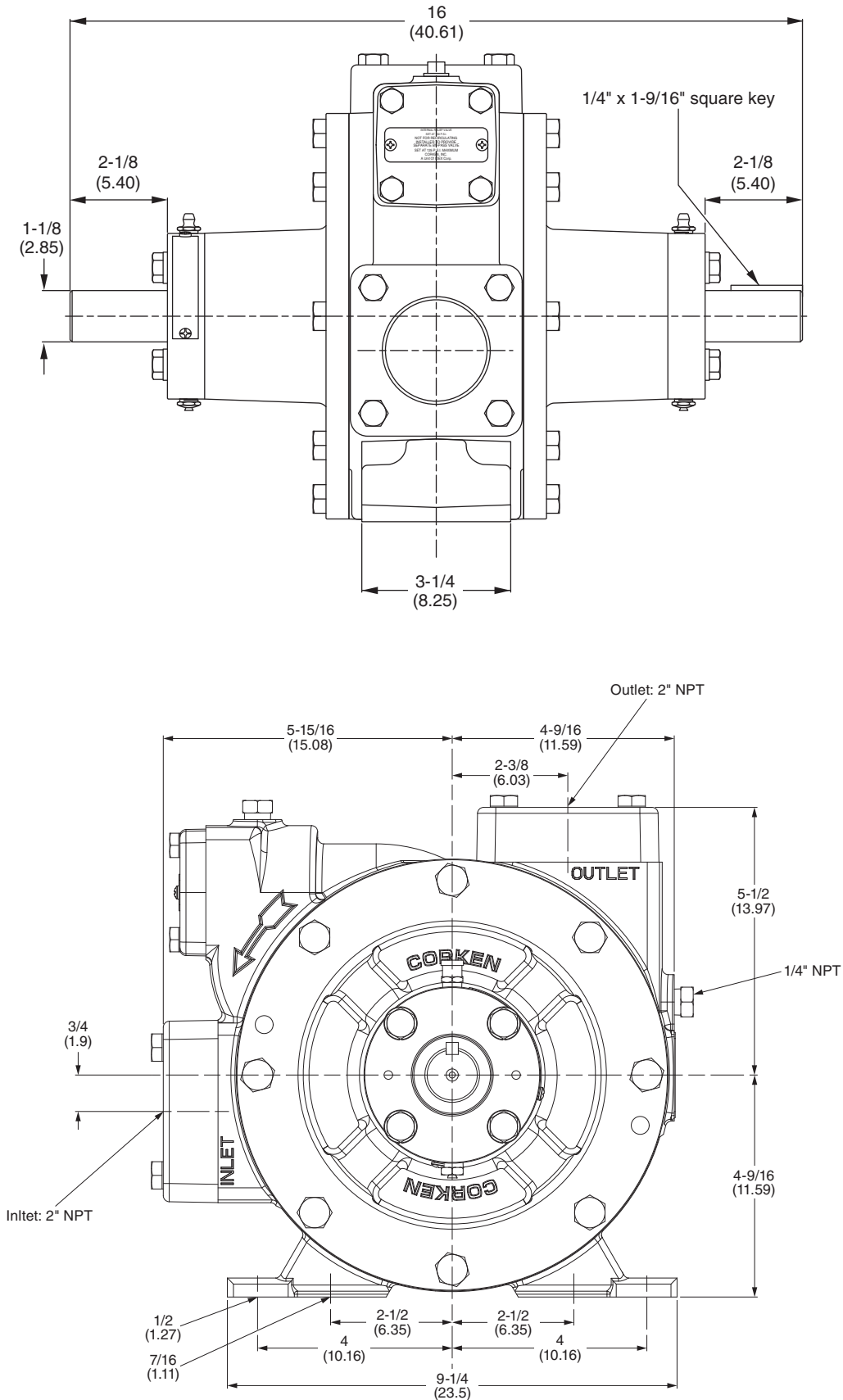

All dimensions are in inches (centimeters).

# Appendix D—Outline Dimensions for Model Z3200

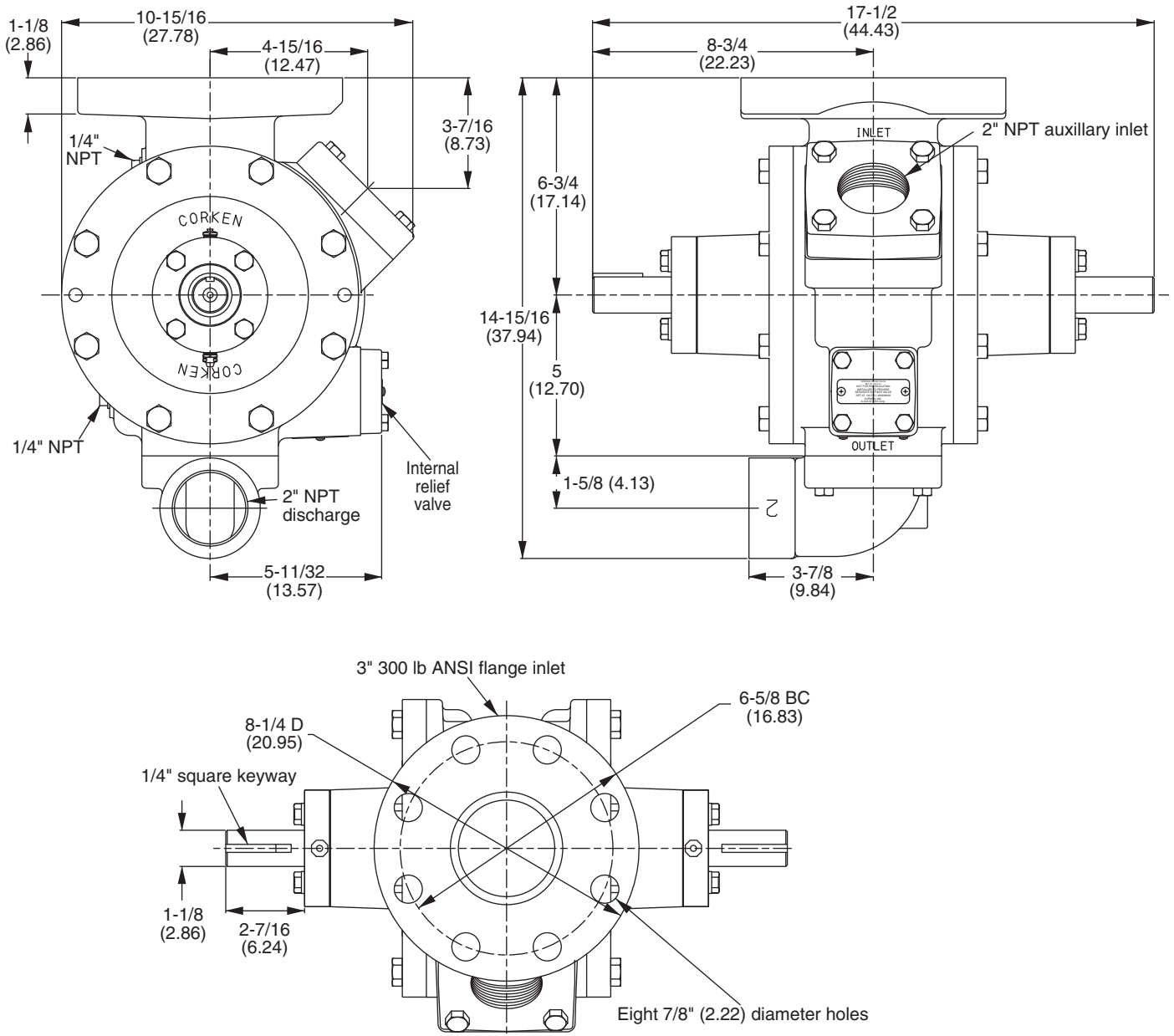

All dimensions are in inches (centimeters).



# Appendix D—Outline Dimensions for Model Z3500

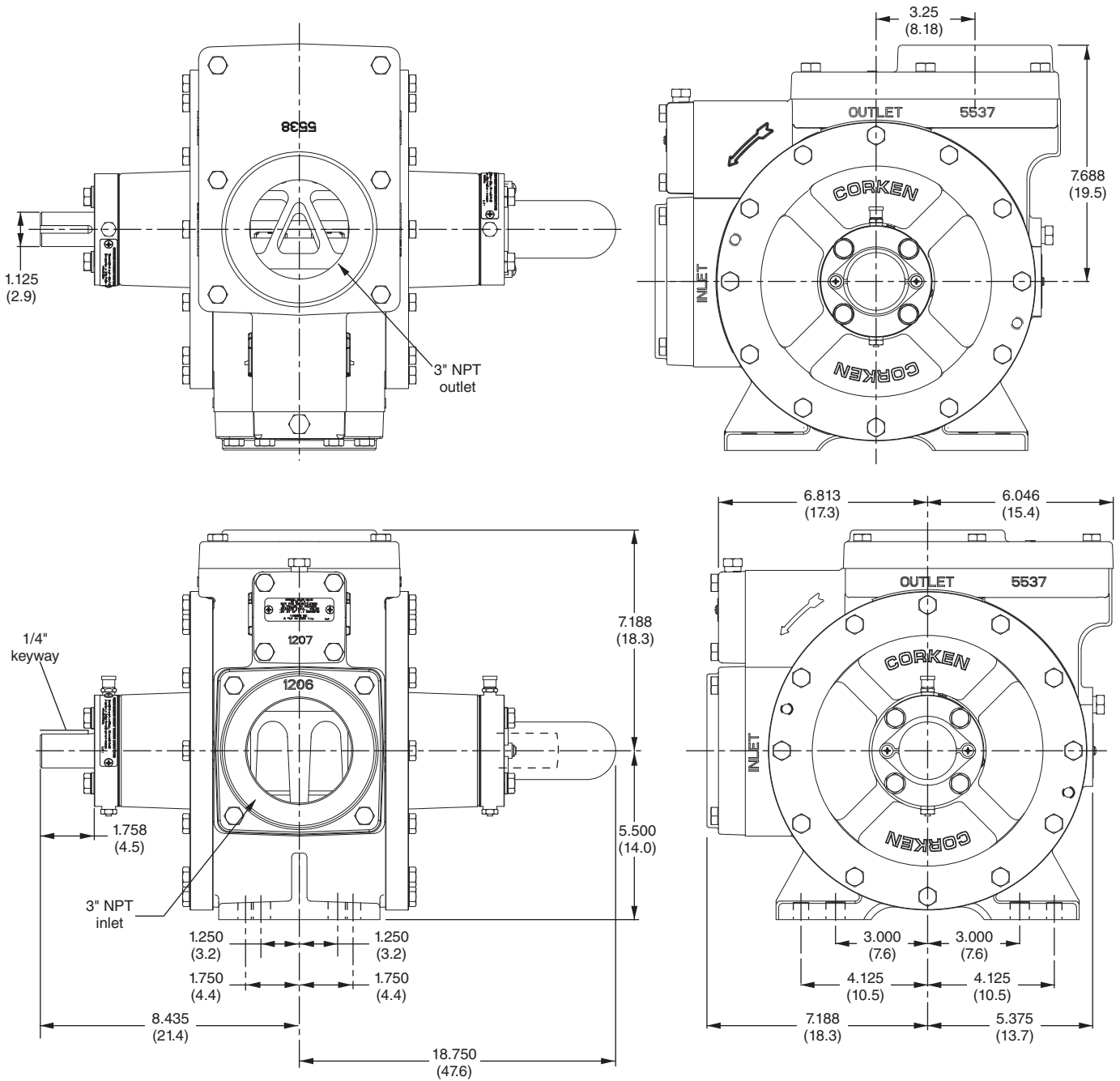

All dimensions are in inches (centimeters).

# Appendix D—Outline Dimensions for Model Z4200

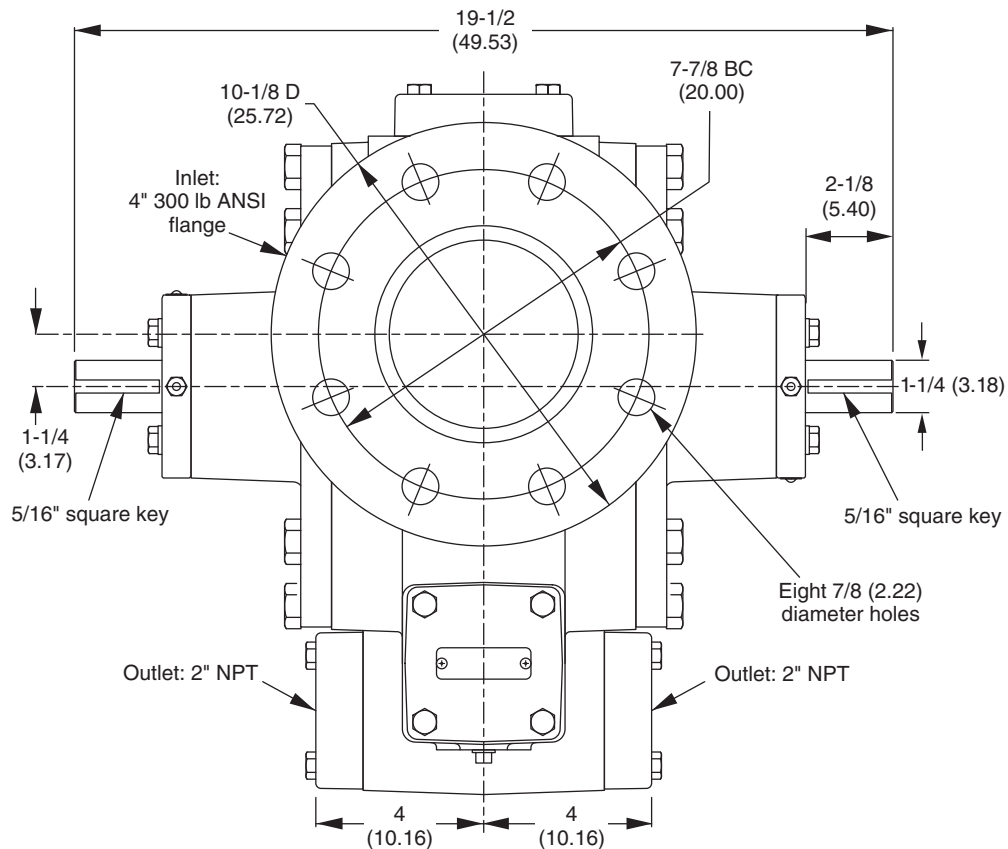
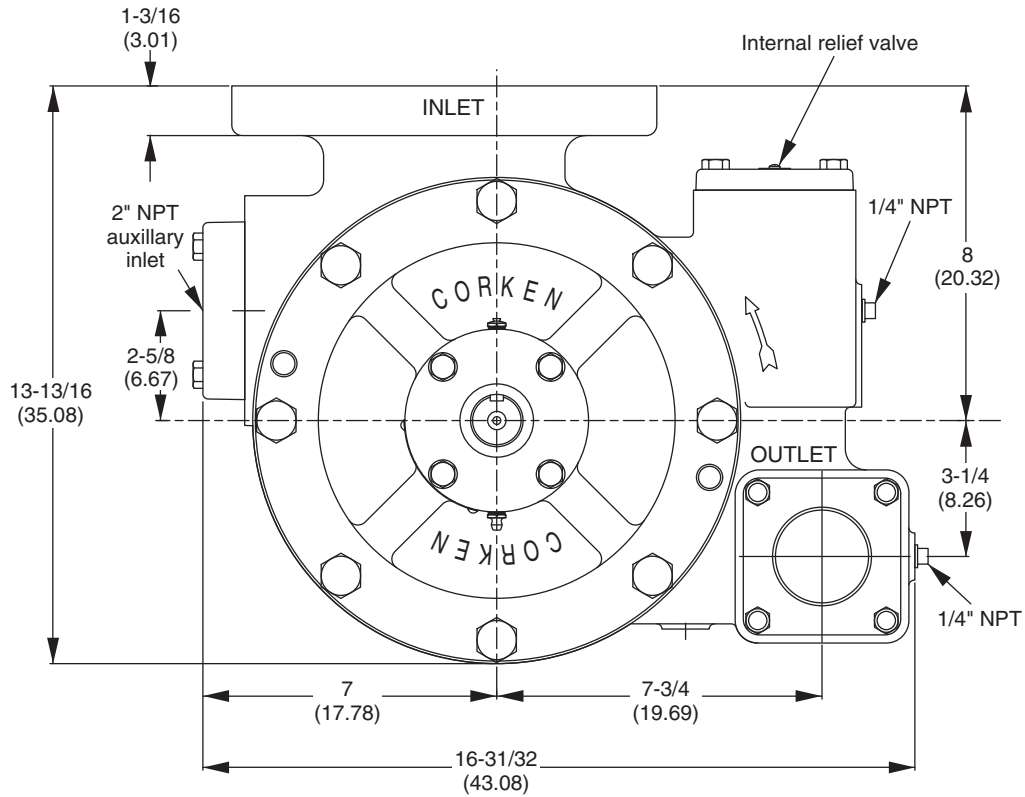

All dimensions are in inches (centimeters).

# Appendix D—Outline Dimensions for Model Z4500

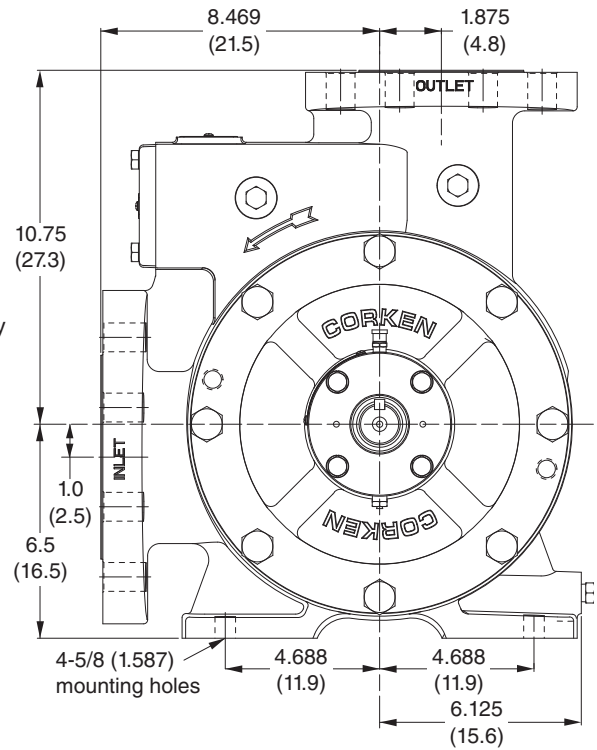
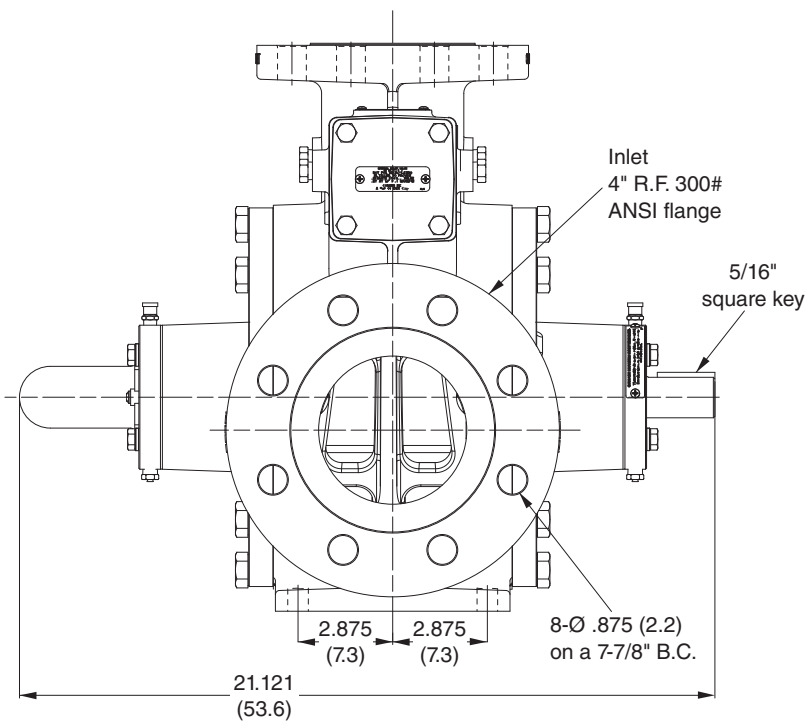
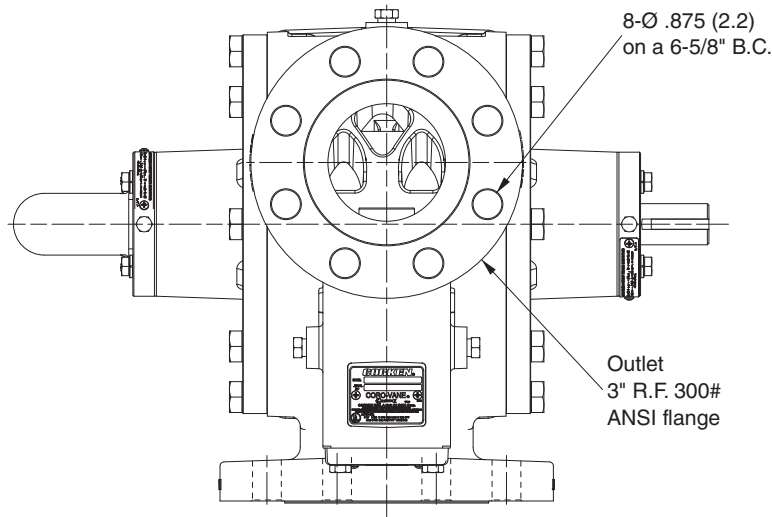

All dimensions are in inches (centimeters).

# Appendix D—Outline Dimensions for Model ZH2000

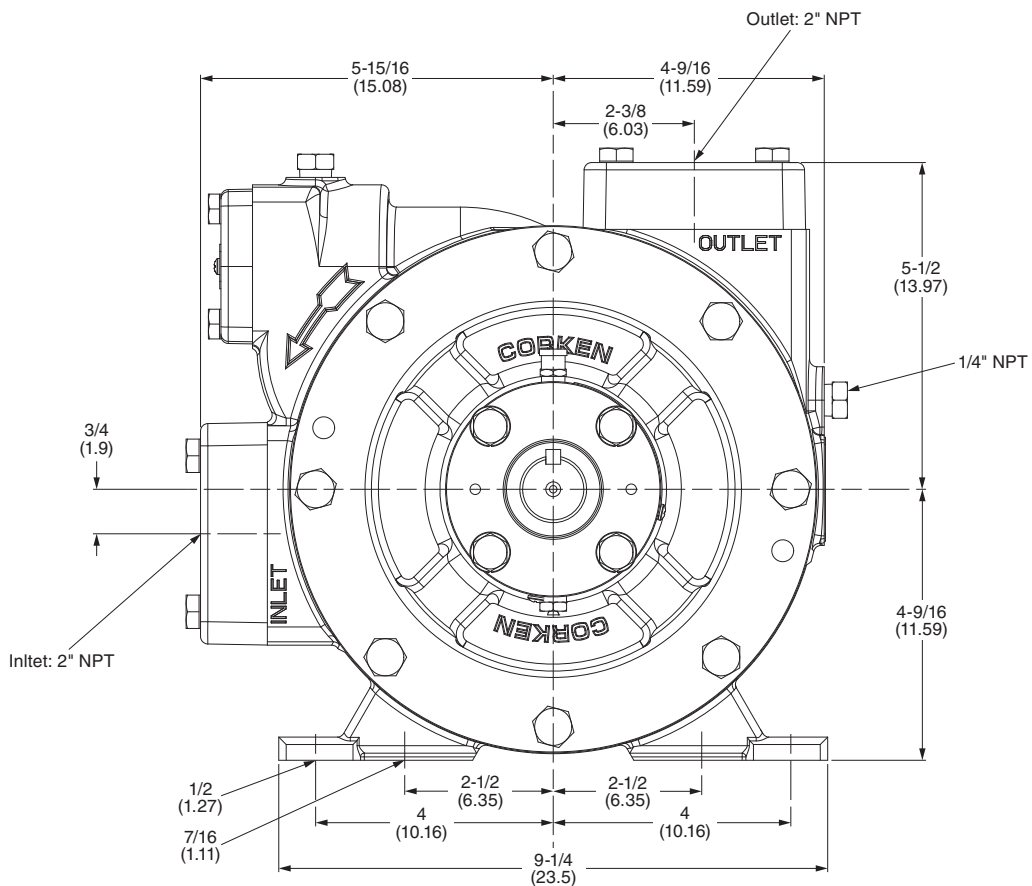
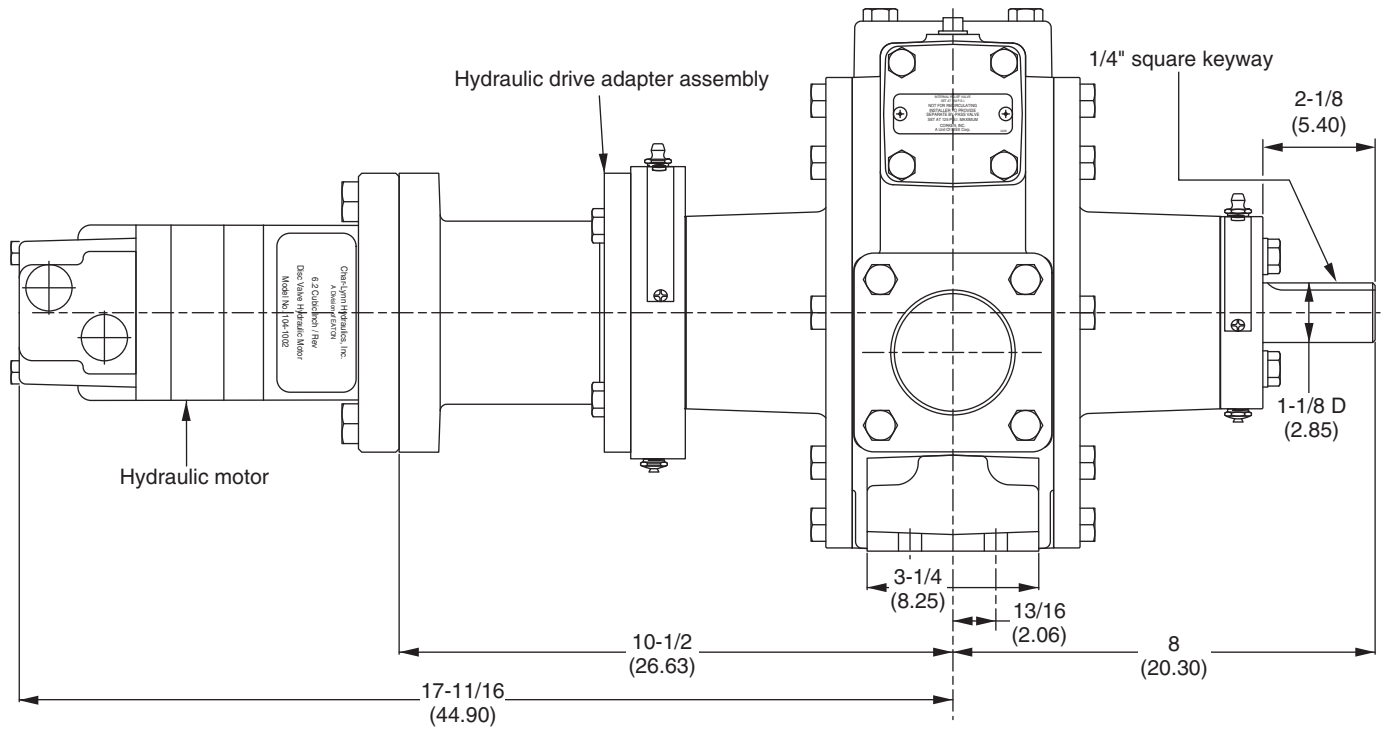

All dimensions are in inches (centimeters).

# Appendix D—Outline Dimensions for Model ZH3200

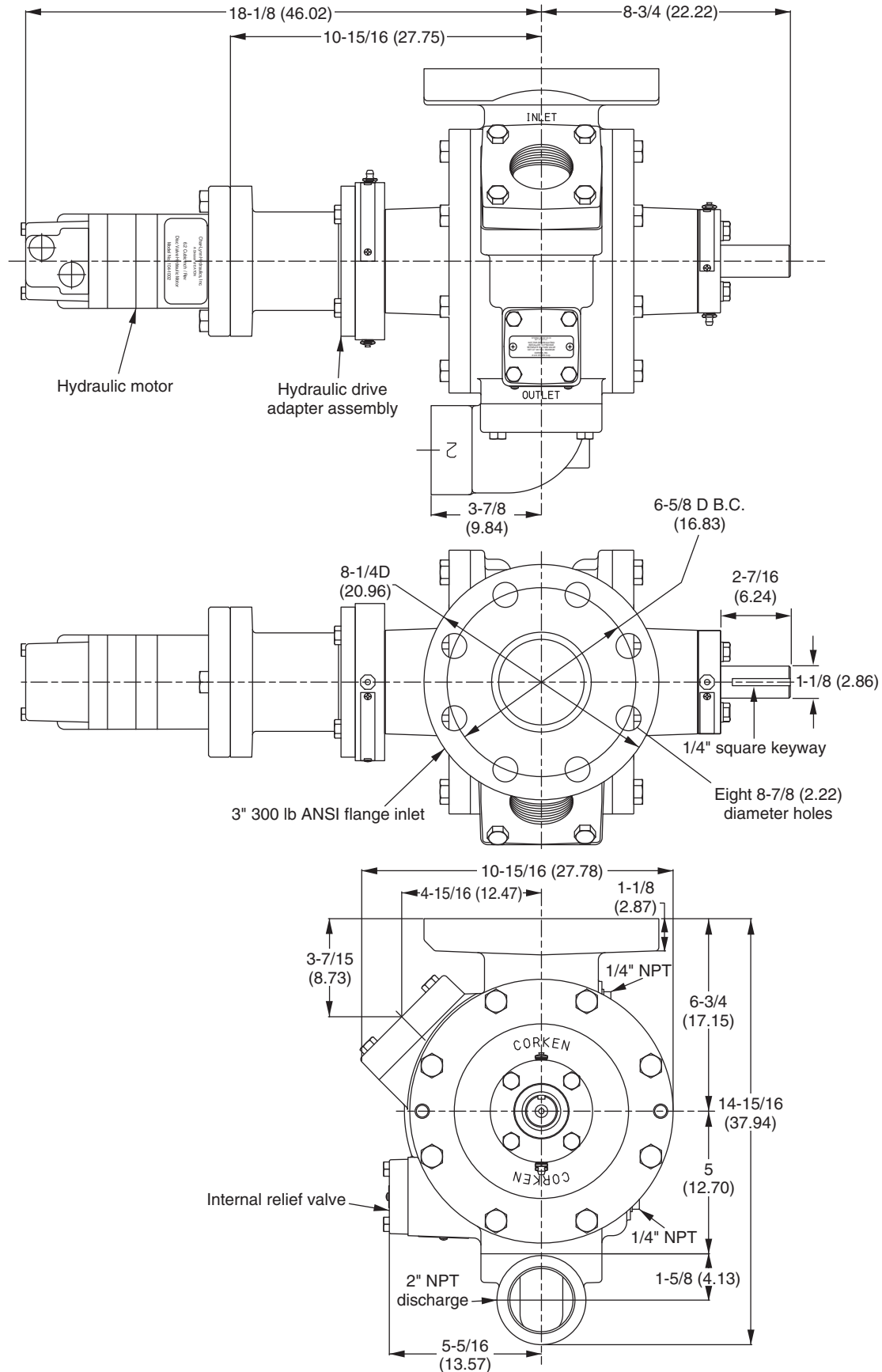

All dimensions are in inches (centimeters).

# Appendix D—Outline Dimensions for Model ZH4200

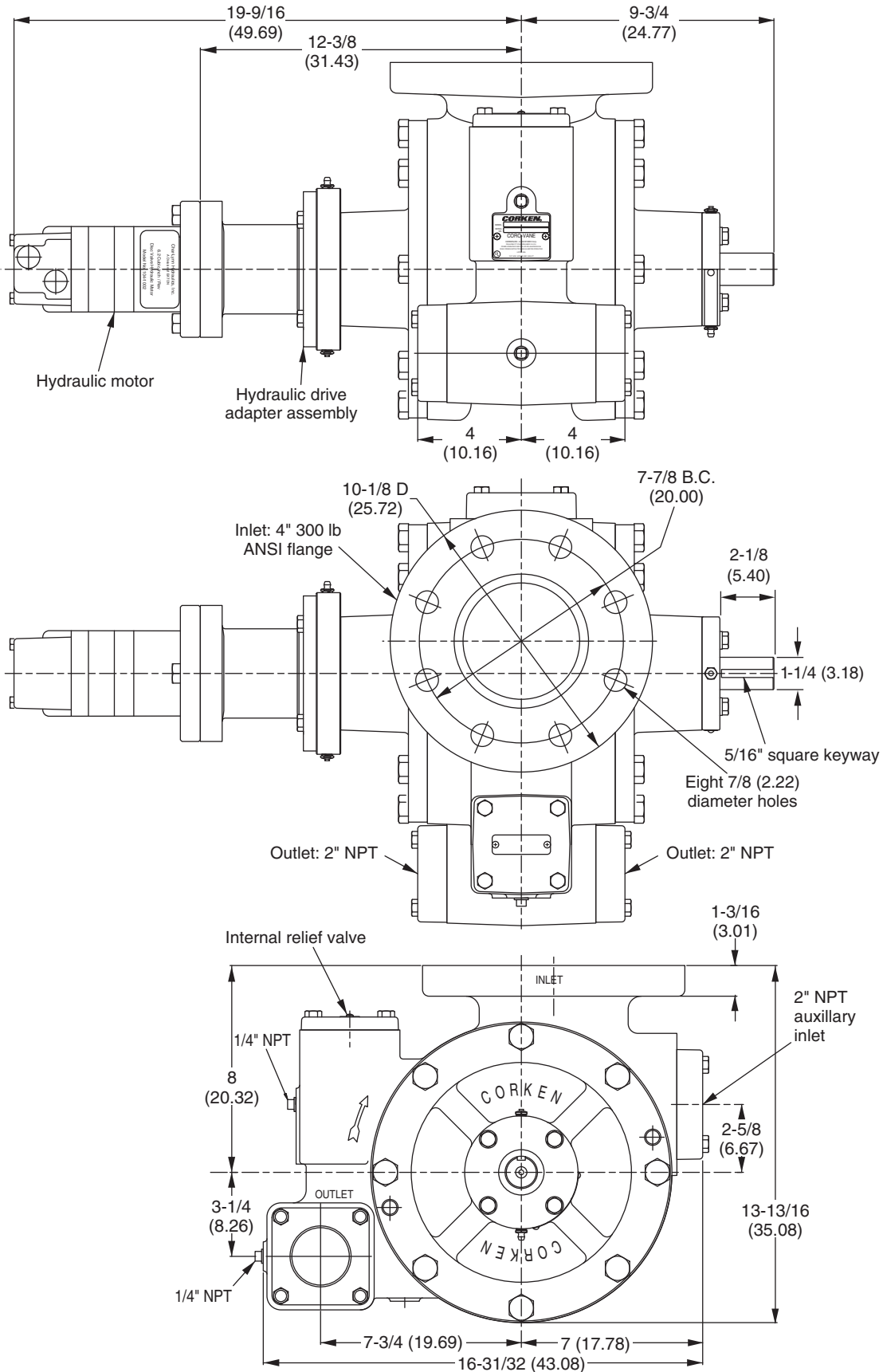

All dimensions are in inches (centimeters).

# Appendix D—Outline Dimensions for Z3500–103 Mounting

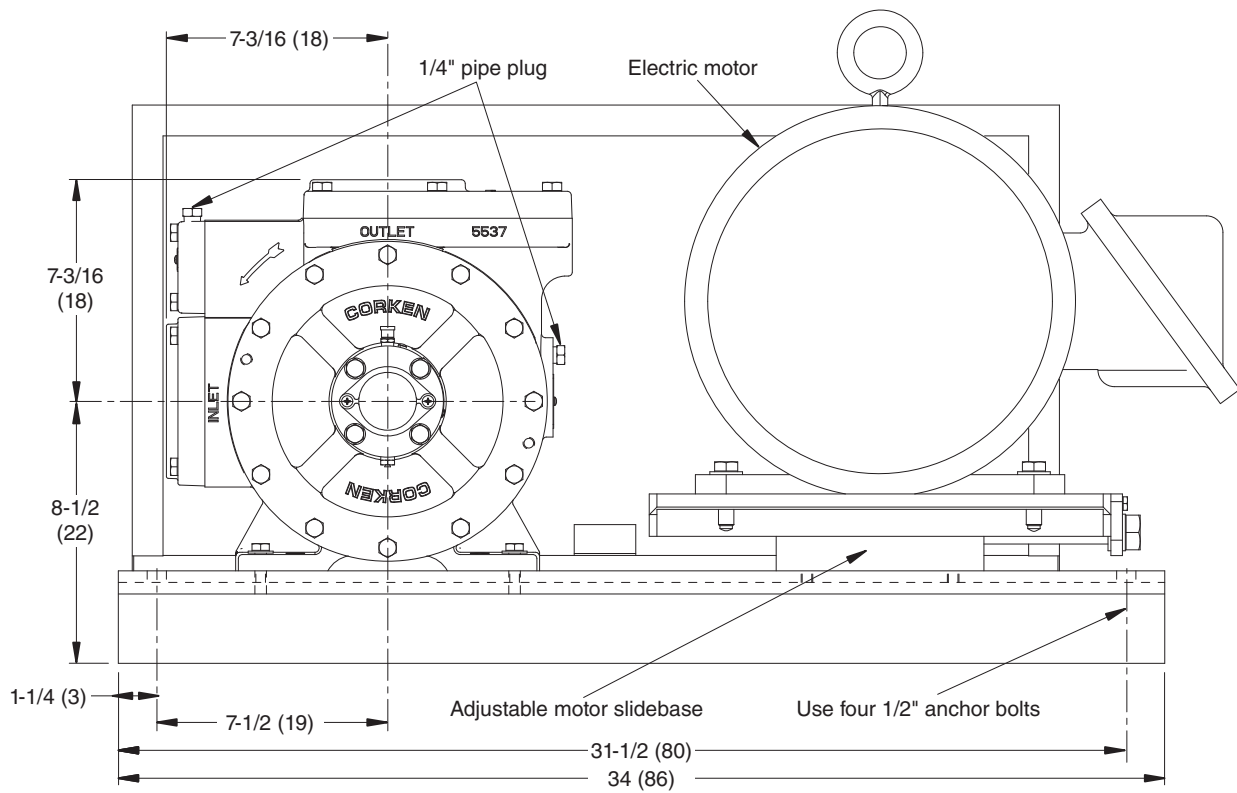
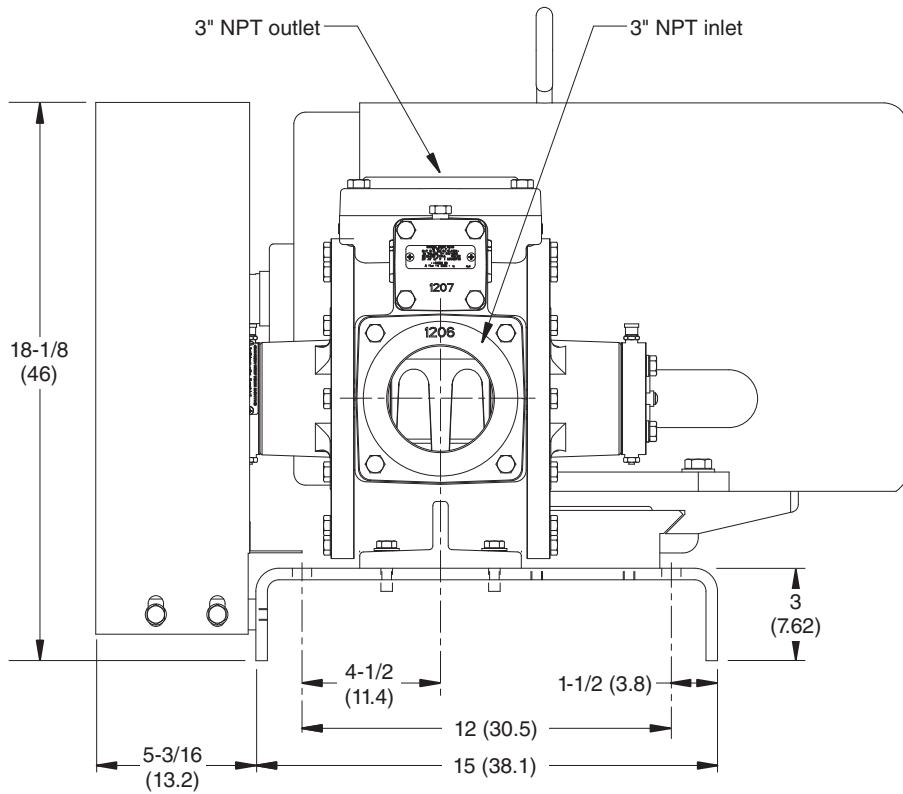

All dimensions are in inches (centimeters).

# Appendix D—Outline Dimensions for Z4500–103 Mounting

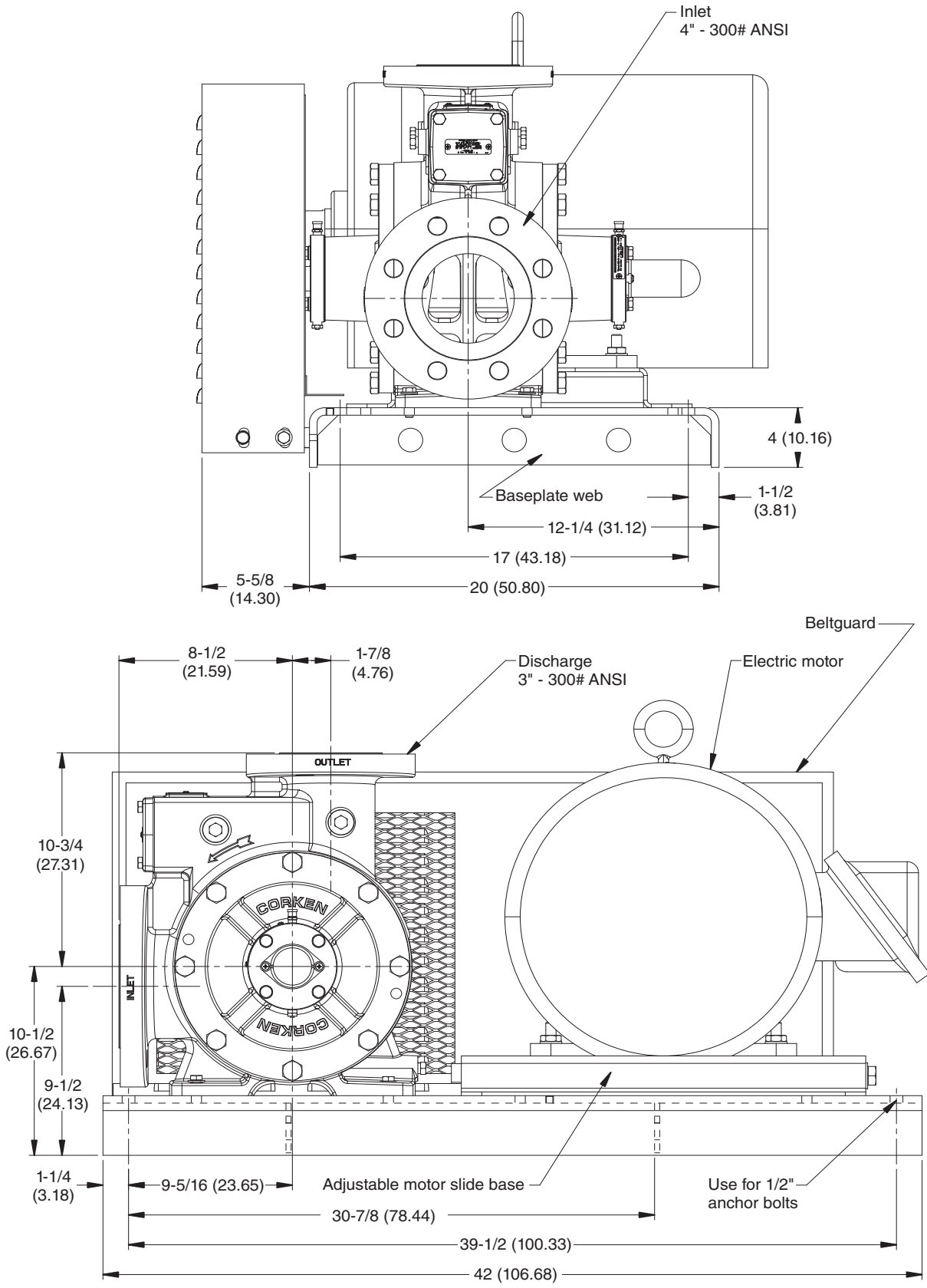

All dimensions are in inches (centimeters).