

SELF ROTATING WHEELS

INLET (M 3 1/4 ACME)

DIRECT DRIVE ENGINE - PUMP REDUCTOR 1/3

PUMP MODEL CORKEN Z2000 (2")

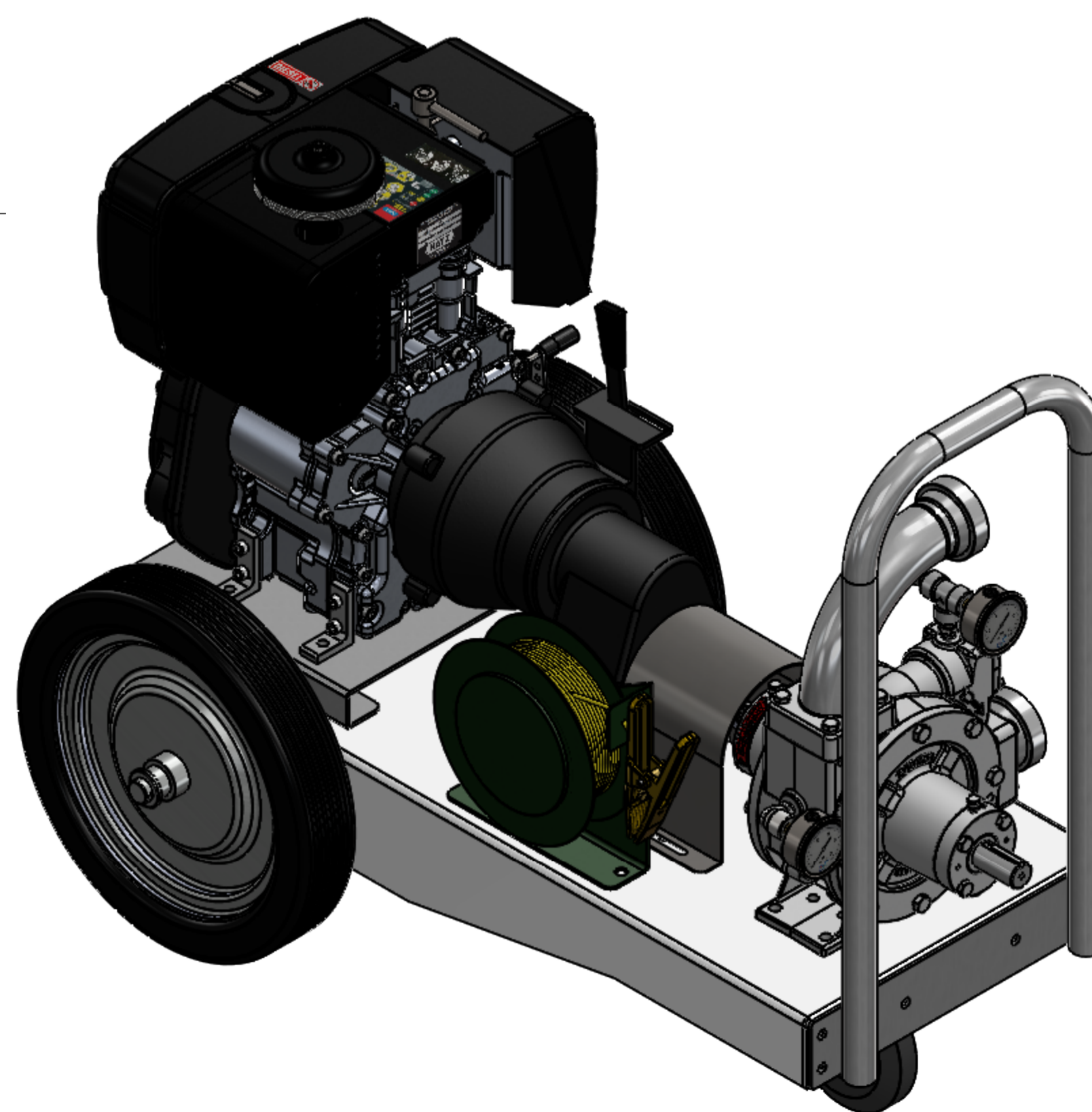
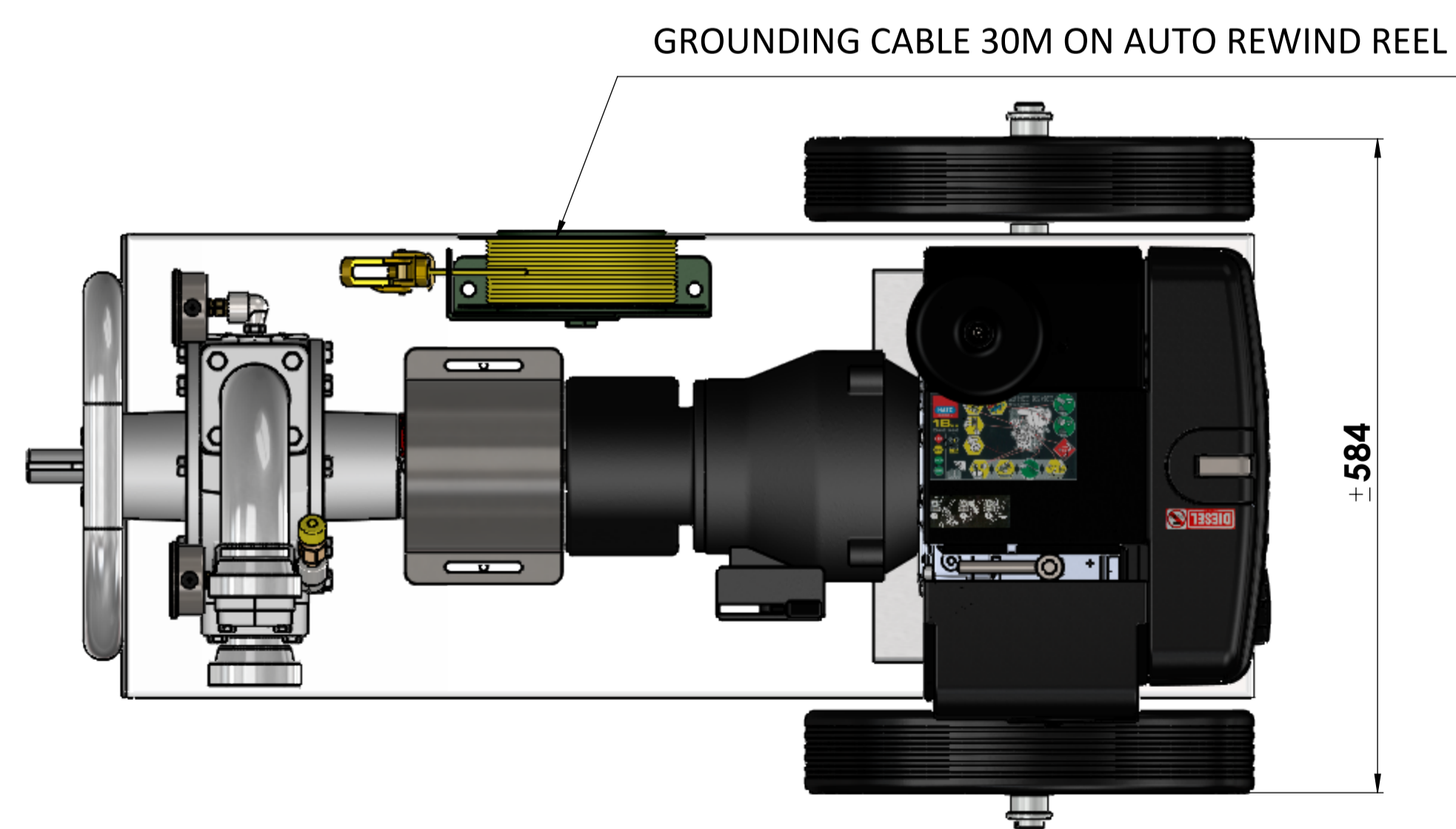

REV.	DESCRIPTION	DATE	APPROUVE
A	Première édition pour proposition commerciale	16/02/2018	JDP
Matière / Material : Acier		Traitement/ finishing : Zinguage blanc	
Dess: JDP Date: 16/02/2018 Echelle/Scale: 1:5		Revision	
±0.1 Tol. générale / General tol.: +/- 0,1		DIESEL 2" CORKEN MOBILE MOTOR-PUMP UNIT	
<small>THE INFORMATION CONTAINED IN THIS DRAWING IS THE SOLE PROPERTY OF EQUIP-FLUIDES. ANY REPRODUCTION IN PART OR AS A WHOLE WITHOUT THE WRITTEN PERMISSION OF EQUIP-FLUIDES IS PROHIBITED.</small>			
<small>EQUIP FLUIDES 2 Rue Lavoisier, 77465 Logny s/ Marne (FRANCE) ☎ (+33) 01.64.12.46.03 ☎ (+33) 01.64.12.46.17</small>		REF PLAN: GMP18-Z2000	REF PIECE: GMP18-Z2000

A