

GRUPE MOTO-COMPRESSEUR ELECTRIQUE CORKEN 91 (GMC10E91)

Electrical Compression unit Corken 91

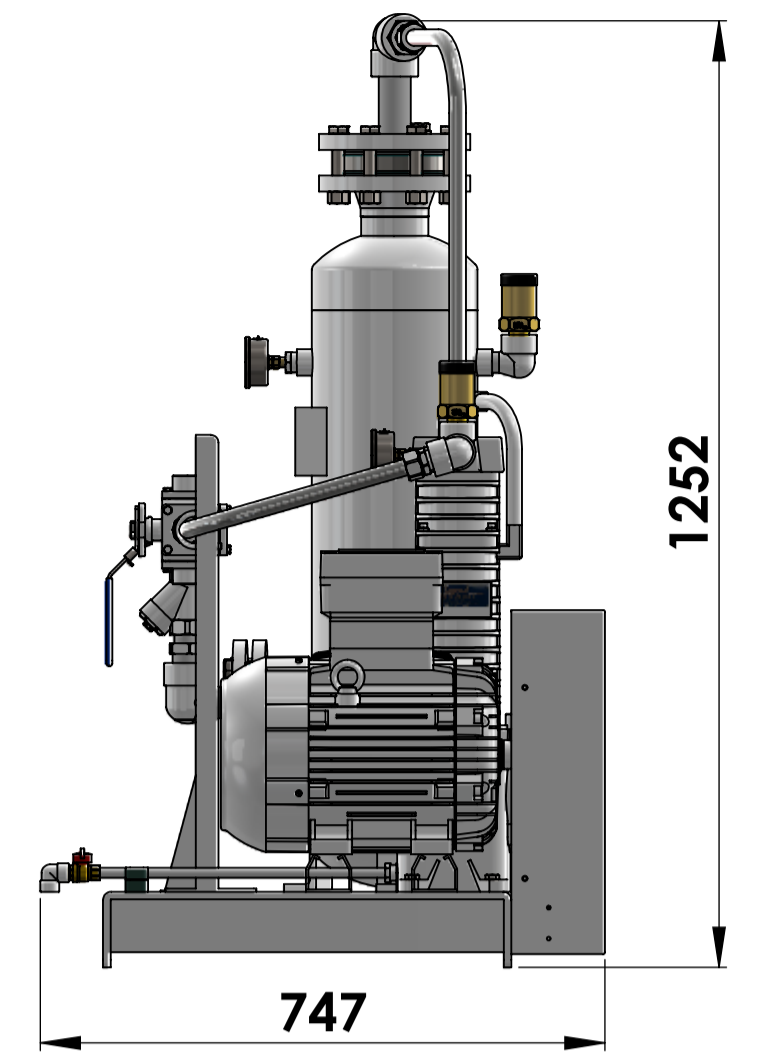
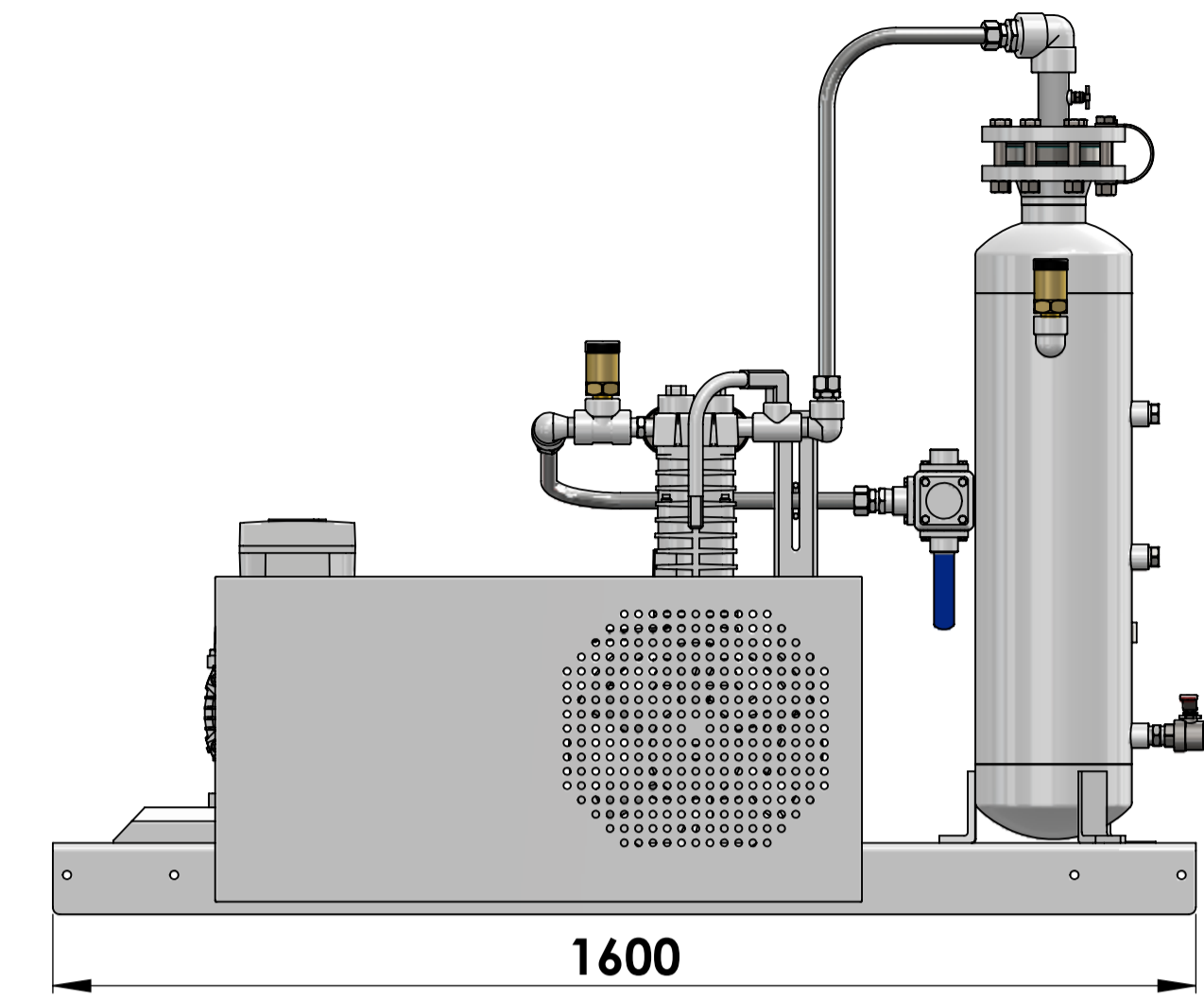
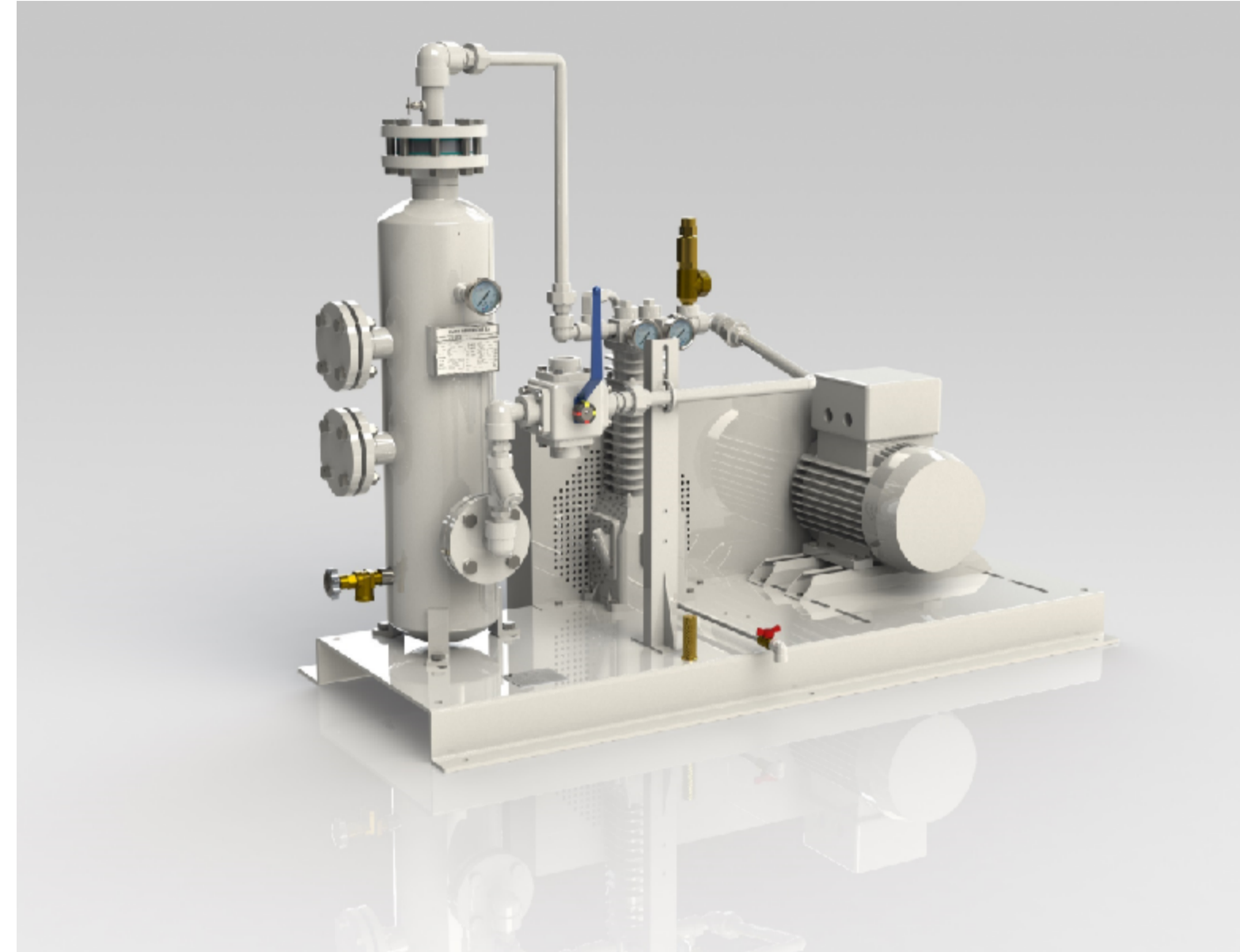

Manomètres aspiration et refoulement
Pressure gauges on inlet and outlet

Soupape 0.75" 17 bar
Relief valve 0.75" NPT 17 bar

Carter courroies amovible
Removable belt cover

Moteur Electrique 5.5Kw 1450Rpm
400Vac 50Hz IE3 ATEX

Performances:
9m³/hr
Pms 21 bar
Puissance moteur 5.5Kw

Piège à liquide 28 litres
Liquid trap 28L

Vanne 4 voies
4 way valve

Filtre
Strainer

Robinet de purge
Drain valve

Chassis renforcé, peinture blanche
Reinforced base plate, white painted

Compresseur Corken 91AJ3FBANSNN
Corken compressor

Dess: JDP Date : 06/01/2022 Echelle / Scale: 1:4	Traitement / finishing :	Revision
 THE INFORMATION CONTAINED IN THIS DRAWING IS THE SOLE PROPERTY OF EQUIP-FLUIDES. ANY REPRODUCTION IN PART OR AS A WHOLE WITHOUT THE WRITTEN PERMISSION OF EQUIP-FLUIDES IS PROHIBITED.	Groupe moto-compresseur CORKEN 91A Electrique 5.5Kw	
EQUIP FLUIDES 2 Rue Lavoisier, 77465 Logny s/ Marne (FRANCE) EQUIP FLUIDES ☎ (+33) 01.64.12.46.03 📠 (+33) 01.64.12.46.17	REF PLAN: GMC10E91	REF PIECE: GMC10E91