

# GRUPE MOTO-COMPRESSEUR ELECTRIQUE CORKEN 491 (GMC10E491)

## Electrical Compression unit Corken 491

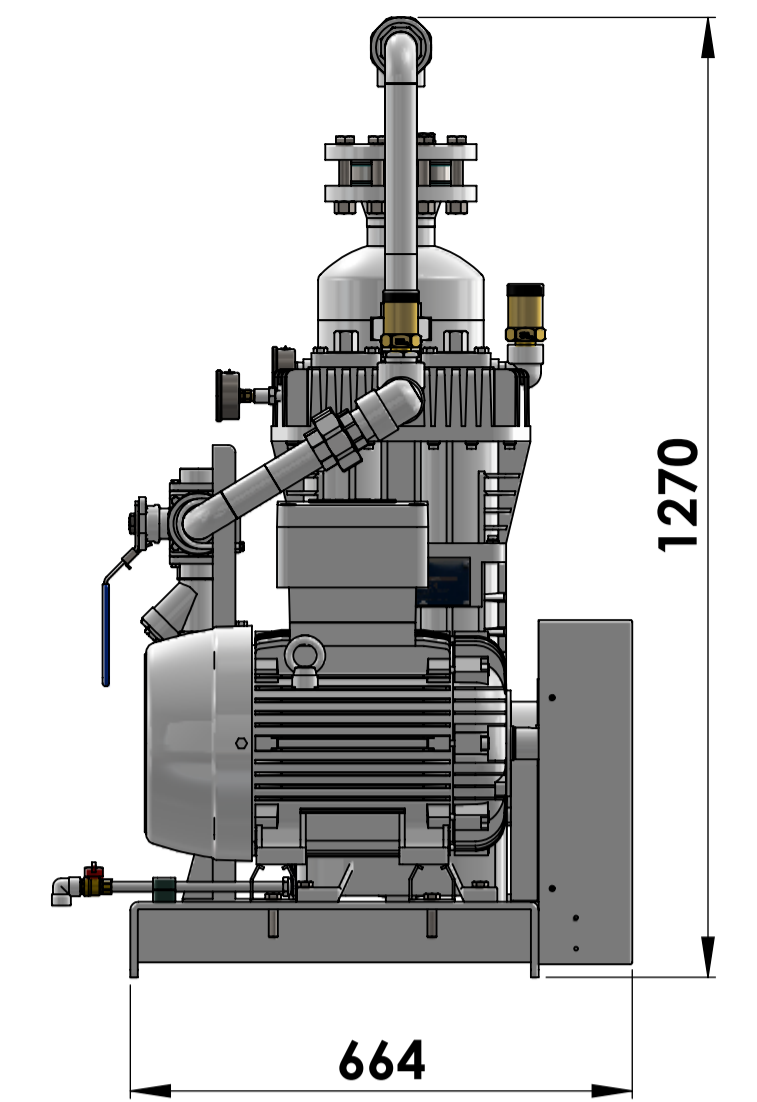
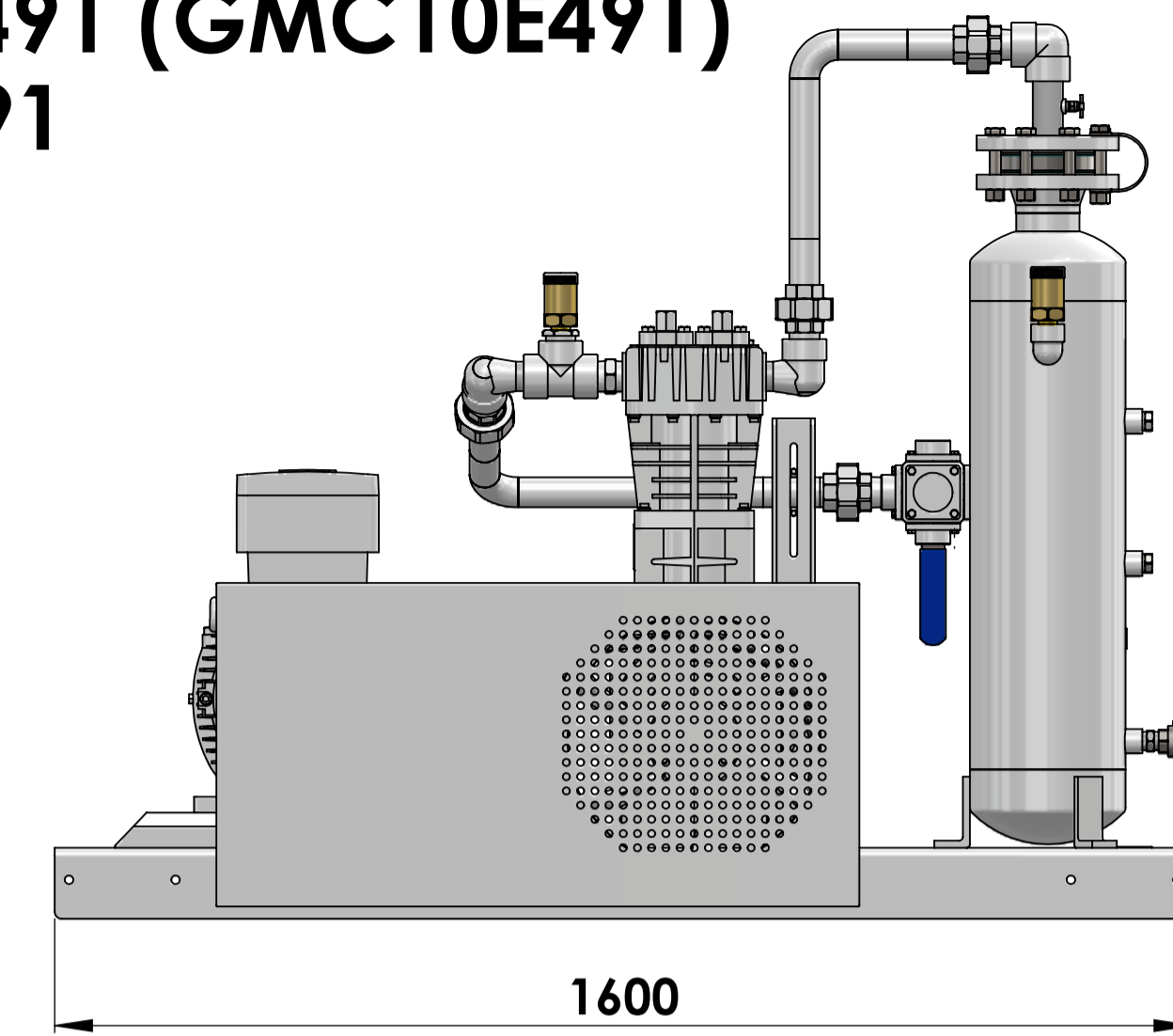

Manomètres aspiration et refoulement  
Pressure gauges on inlet and outlet

Soupape 0.75" 17 bar  
Relief valve 0.75" NPT 17 bar

Carter courroies amovible  
Removable belt cover

Moteur Electrique 11Kw 1450Rpm  
400Vac 50Hz IE3 ATEX

Piège à liquide 28 litres  
Liquid trap 28L

Vanne 4 voies  
4 way valve

Filtre  
Strainer

Robinet de purge  
Drain valve

**Performances:**  
49m<sup>3</sup>/hr  
Pms 21 bar  
Puissance moteur 11Kw

Chassis renforcé, peinture blanche  
Reinforced base plate, white painted

Compresseur Corken 491AM3FBANSNN  
Corken compressor

Manomètre de pression d'huile  
Oil pressure gauge

Dess: JDP   Date : 07/01/2022   Echelle / Scale: 1:4	Traitement / finishing :	Revision
 Tol. générale / General tol.: +/- 0,1 THE INFORMATION CONTAINED IN THIS DRAWING IS THE SOLE PROPERTY OF EQUIP-FLUIDES. ANY REPRODUCTION IN PART OR AS A WHOLE WITHOUT THE WRITTEN PERMISSION OF EQUIP-FLUIDES IS PROHIBITED.	Groupe moto-compresseur Corken 491 électrique 11Kw (Version standard)	
EQUIP FLUIDES 2 Rue Lavoisier, 77465 Logny s/ Marne (FRANCE) EQUIP FLUIDES : (+33) 01.64.12.46.03 - : (+33) 01.64.12.46.17	REF PLAN: GMC10E491	REF PIECE: GMC10E491